



**ECPL Fertilizer Plant Expansion Project**  
**Environmental Impact**  
**Assessment**

**Final Report**

HBP Ref.: R7V03DEE

**June 18, 2007**

**Engro Chemical Pakistan Limited**

Daharki

## Executive Summary

---

Engro Chemical Pakistan Ltd. (ECPL) plans to enhance its existing urea manufacturing capacity by setting up a new Ammonia Urea complex within its existing facility in Daharki Sindh. The subject installations will be state of the art and the most environment friendly in the country. The proposed project will increase the existing annual production of 975 kilotons (KT) of Urea by 1,267 KT resulting in a total annual production of 2,242 KT.

To facilitate the increase in production of urea, expansion in the existing utilities of the plant will also be undertaken. Furthermore, a new offsite water facility will also be developed as part of this project (see **Exhibit I**).

### Policy, Statutory, and Institutional Framework

The Pakistan Environmental Protection Act, 1997 is the basic legislative tool empowering the government to frame regulations for the protection of the environment. The key features of the law that have a direct bearing on the proposed project relate to the environmental assessment for development projects. The Pakistan Environmental Protection Agency Review of IEE and EIA Regulations, 2000 (IEE-EIA Regulations, 2000), prepared by the Pak-EPA under the powers conferred upon it by the PEPA, 1997 categorizes projects for IEE and EIA. Schedules I and II, attached to the IEE-EIA Regulations, 2000, list the projects that require IEE and EIA, respectively. The proposed project falls into the category that requires an EIA. The National Environmental Quality Standard (NEQS), first promulgated in 1993 and amended in 1995 and 2000, sets the gaseous emissions and liquid effluent limits from industrial sources.

The IFC and the World Bank require all projects funded by these agencies to be constructed and operated in an environmentally responsible manner. All projects that receive IFC funding must therefore comply with appropriate World Bank Group environmental policies and guidelines. The EIA has been carried out to comply with both national and IFC guidelines. The key documents of the IFC are the Environment and Social Review Procedure (ESRP) and the IFC's Performance Standards on Social and Environmental Sustainability. The key World Bank document is the *Pollution Prevention and Abatement Handbook 1998: Towards Cleaner Production*.

The proposed project will meet the applicable regulatory requirements as laid down in the Pakistan Environmental Protection Act, 1997, its associated rules and regulations, and other laws as described above and also the requirements of the IFC as laid out in its policy, performance standards, procedures, and guidelines.

### Project Description

ECPL intends to set up an additional urea and ammonia plant at its existing fertilizer manufacturing facility in Daharki. The new development will include the addition of 2,194 metric tons per day (MTD) ammonia plant, a 3,835 MTD urea plant, offsite

facilities and incremental utilities. ECPL envisions adding 1,267 kilotons (KT) per year of production to its existing 975 KT per year production of fertilizer.

In addition to the plants, the incremental utilities and offsite facilities which include water intake and storage facilities, addition in water treatment and cooling facilities, gas turbine with heat recovery steam generator, air compressor, nitrogen generator, and a new gas supply pipeline from Qadirpur to Daharki delivering 100 MMscfd of natural gas will also be developed.

The project will be installed within the boundaries of the existing ECPL facility in Daharki and adjacent to the existing fertilizer manufacturing plant. The ECPL complex is located about 300 m south of the national highway. Major industrial units in the vicinity of the existing plant are the Liberty Power Plant and the Fauji Fertilizer Company (FFC) plant located 3 km and 13 km west of the ECPL plant respectively. The ECPL housing colony and Mari Gas Company Limited housing colonies are located adjacent to the ECPL plant. The project site and its vicinity are shown in Exhibit II.

### **Existing Plant Facilities and Operations**

The existing fertilizer plant is in operation since 1968, most of the facilities have been developed over last 40 years of operation, which include the plant, residential colonies & offsite facilities.

The fertilizer manufacturing process consists of two stages: Ammonia production and subsequently urea production. ECPL currently have one operational ammonia plant and two urea plants.

The ammonia plant being used was initially designed to produce 1,060 metric tons (MT) of liquid anhydrous ammonia per operating day from natural gas, steam and air but its production capacity was enhanced to 1,650 MT through major equipment modifications. The sequence of steps involved in ammonia production is as follows:

- ▶ Feed gas compression through Natural Gas Booster Compressor.
- ▶ Feed Gas Desulphurization
- ▶ Pre-Reforming
- ▶ Primary Reforming
- ▶ Secondary Reforming
- ▶ Carbon Monoxide shift conversion
- ▶ Carbon Dioxide removal
- ▶ Methanation
- ▶ Removal of residual carbon dioxide (CO<sub>2</sub>) and water
- ▶ Synthesis gas compression
- ▶ Catalytic conversion of synthesis gas to ammonia
- ▶ Condensation of ammonia

### **Proposed Development Project**

Expansion of the existing Ammonia and urea manufacturing plants include the installation of following new units and facilities:

- ▶ Proposed ammonia plant
- ▶ Proposed urea plant
- ▶ Additional gas pipeline from Qadirpur
- ▶ Addition in existing utilities unit
- ▶ New Off-site water facility
- ▶ Expansion of existing ECPL residential colony
- ▶ Effluent treatment plant

### **Environmental Setting**

The project area is located in the sedimentary Southern Indus Basin south of the Sukkur Rift—the divide between the Central and Southern Indus Basins. The Southern Indus Basin consists of the Thar Slope Platform, the Karachi Trough, the Kirthar Foredeep, the Kirthar Fold Belt, and the Offshore Indus. The project location is surrounded by cultivated land. Soil types range from dark brown sandy loam in most places to light-brown sand in others. The area's soils contain adequate moisture and nutrients for agricultural use.

The climate of the project area is broadly described as hot and arid. The region is characterized by aridity and continentality, with high summer temperatures and late summer rains. Rainfall is less than 250 mm and concentrated in June to September. July and August are the hottest months and October and November the driest. June and January are the hottest and coldest months, respectively. The presence of irrigated fields mitigates the summer heat to some extent.

The ECPL's existing fertilizer plant, the Liberty power plant, and the Fauji Fertilizer Company (FFC) fertilizer plant are the significant sources of gaseous emission in the project area. Other sources of gaseous emissions are the vehicular exhaust emissions from the highway traffic in the area.

The area surrounding the proposed project site does not contain any natural surface water bodies such as rivers, springs, etc. The Indus River is flowing in from Punjab and heading southwards into the Arabian Sea is located approximately 20 km northwest of the project area. The main surface water bodies in the surroundings of the project area are the two irrigation canals, the 'New Mahi Wah' and the 'Dahar Wah'. The New Mahi Wah is located approximately 3 km west of the ECPL facility. The groundwater aquifers in the project area are described as moderately thick and extensive with a potential yield of between 100 and 150 m<sup>3</sup>/h (Survey of Pakistan, 1989). Groundwater in the area is saline and is tapped through hand pumps and wells. The water table in the project area is shallow (less than 2 m).

The area surrounding the ECPL facility is irrigated agricultural land, and does not support rare or threatened plant species. All the plant species present in the site are cultivated.

Acacia nilotica, Dalbergia sisso, Alibizia lebbek, Euclyptus camaldanesis and Zizyphus numularia are the tree species that are planted along the margins of agricultural fields. These plants are mostly used by the local for fodder and fuel wood purposes.

The proposed project site is located in a completely modified area, with no natural wildlife habitat in the vicinity. Only very common and adaptable animal species are found in the project area. No threatened and vulnerable animal, birds and reptile species are reported from the area. Asiatic jackal, Indian crested porcupine, desert fox and palm squirrel are the common large animals that are found in the project area. Other small mammals that are reported from the area are Indian desert jird, house rat, Indian jerbil and house mouse.

The project area is inhabited by number of resident and migratory birds. Common kingfisher, little brown dove, little egret, cattle egret, house crow, Indian robin common myna, white-cheeked, common babbler, house sparrow, and white wagtail are the common resident birds that are found in the project area.

The complete list of flora and fauna observed or reported from the area are presented as **Appendix C**.

The study area is located in Ghotki District. of Sind Province. Ghotki District comprises of five Talukas i.e. Daharki, Ghotki, Khangarh, Mirpur Mathelo and Ubauro. Most of the study area is located in Daharki Taluka. A small portion in the west is in Mirpur Mathelo Taluka.

As per the survey for the EIA, there are 10 villages or settlements in the project area. The size of the villages ranges from 15 to 2,630 houses. The average household size in the study area is 6.1 as compared to the average household size of 5.5 in the Ghotki district (Population Census Organization, 2000).

Majority of the people in the project area are engaged in agriculture. Their socioeconomic condition on the whole is not very encouraging. Only a few persons own big landholdings. The rest are either landless *haris* or petty *khatedar*s. The practice of livestock rearing is purely for household needs and not for commercial purposes. Groundwater is an important source of drinking water in the project area. Almost every house in the area has a hand pump. It was observed that drinking water from most of these sources is sweet and of good quality.

## **Environmental Impacts and Mitigations**

The potential environmental and social impacts of the proposed activities are assessed using the standard impact assessment methodology. It starts with scoping, through which potential environmental issues associated with the proposed project are identified. This is followed by definition of the criteria for determining significance of the impact, prediction of the magnitude of the impact, assessment of significance, identification of mitigation measures to reduce the adverse impacts to acceptable levels, evaluation of residual impacts, and identification of monitoring requirements.

The main impacts associated with the construction phase of the project are shown in **Exhibit III**. The exhibit also shows the criteria for determining significance and the key mitigation measures proposed to minimize the impacts.

Other minor environmental impacts that have been discussed and for which mitigation measures have been proposed include: vehicle and equipment exhaust, drainage and storm water run-off, camp effluent, and impact on wildlife. Other social impacts such as, impact on cultural resources and impact on archeological resources are also evaluated.

The main impacts associated with the operation phase of the project are shown in **Exhibit IV**. Other minor environmental impacts that have been discussed and for which mitigation measures have been proposed include disposal of operation related wastewater, and management of hazardous material.

## **Conclusion**

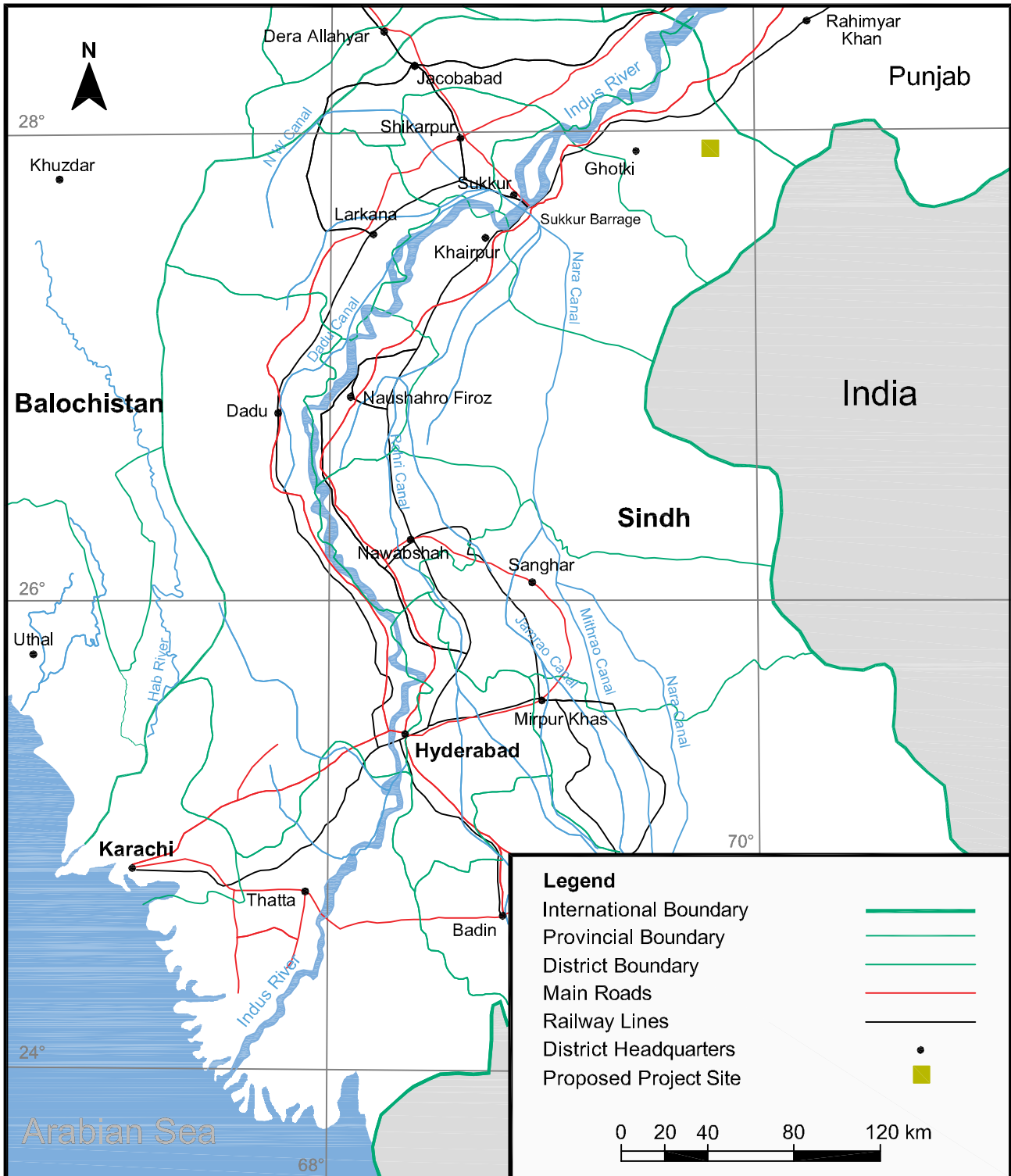
It is concluded that if the field activities, including the implementation of all mitigation measures, are carried out as described in this report, the anticipated impact of the project on the area's natural and socioeconomic environment will be well within acceptable limits. The project will also comply with all the statutory requirements, national and international standards.

To ensure implementation of the mitigation measures an environmental management plan for the construction phase will be prepared separately. EPCL, as part of its core value, is committed to ensure that the potential impacts of this project both on environment and socioeconomic climate are fully assessed. It has an elaborate Environmental Management System (EMS), certified and regularly audited for ISO-14001:2004. The existing EMS will govern the post-expansion operations as well. A preventive maintenance philosophy, supported by robust inspection plans and sound operational practices will be adopted to ensure sustainable and safe operation of the site.

All concerns and their mitigation plans will be part of the Construction Health, Safety, and Environment (HSE) manual. Regular monitoring of all HSE activities will be done and a monthly stewardship report will be issued.

Engro Chemical Pakistan Limited has a very robust community development program primarily focusing on health, education, infrastructure development, and environment. Most of these programs are in partnership with government departments and renowned NGOs. Organization as a policy allocates 1% of its pretax profits to community development and with the expanded plant Engro revenues will increase therefore, funds available for community development projects will also increase.

The priority in employment will be given to the communities in the surroundings of the project area for all unskilled jobs as is the case in current scenario where 80% of unskilled labor is from the surrounding areas. In addition to this a lot of skilled jobs are also with local community members.



**Legend**

- International Boundary ———
- Provincial Boundary ———
- District Boundary ———
- Main Roads ———
- Railway Lines ———
- District Headquarters ●
- Proposed Project Site ■

0 20 40 80 120 km

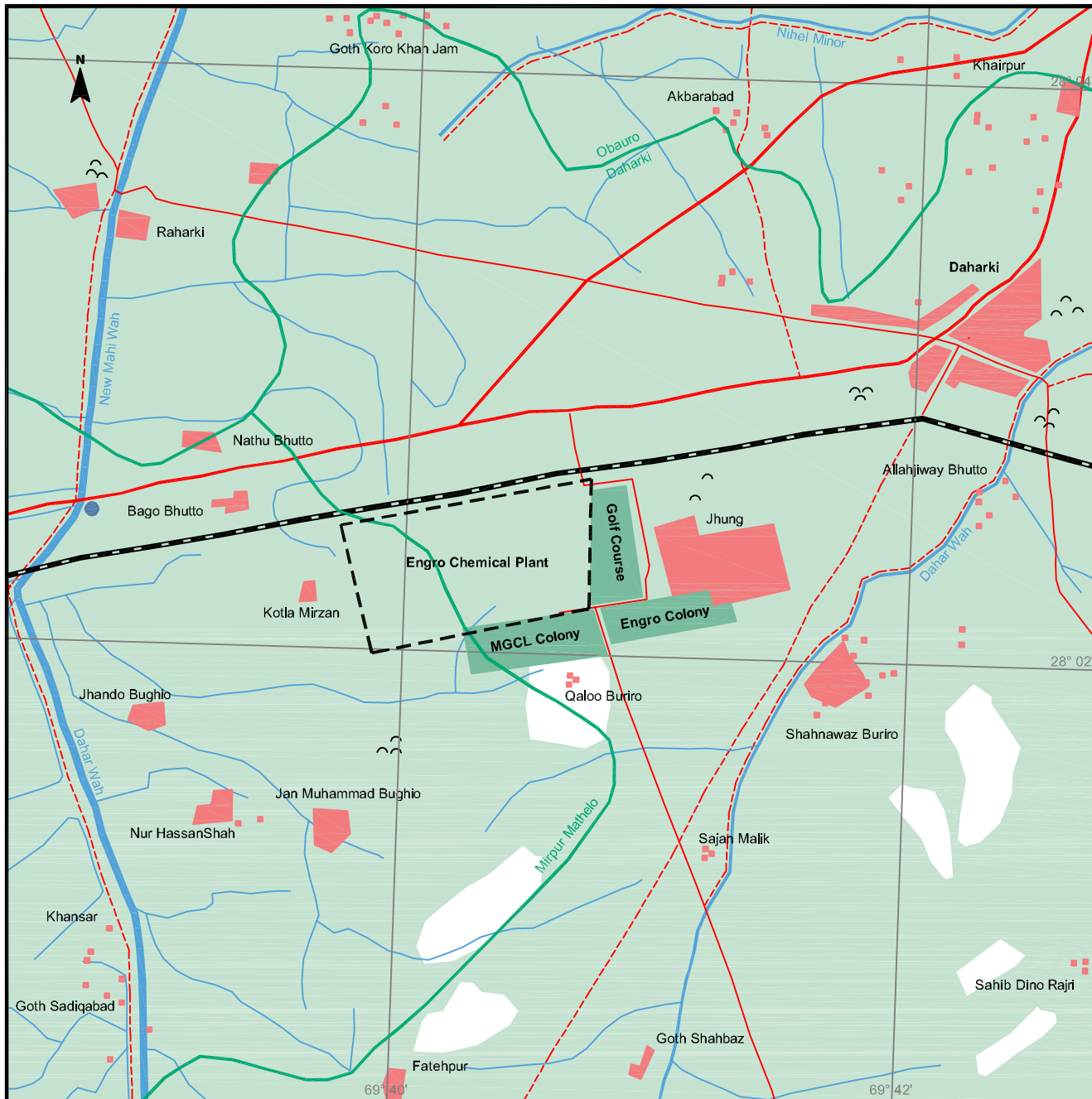
**EIA of ECPL Expansion Project**

**Exhibit I**

**Project Location**

<b>Scale</b>	1 : 2,750,000
<b>Source</b>	Survey of Pakistan
<b>Drawing</b>	W6E01DEE
<b>Date</b>	May 2007
<b>Client</b>	Engro Chemicals Pakistan Limited

**Hagler Bailly Pakistan**



- Legend**
- Highway
  - Metalled Road
  - Jeepable Track / Trail
  - Railway Line
  - Taluka Boundary
  - Canals
  - Settlement
  - Graveyard
  - Offsite Water Facility



**EIA of ECPL Expansion Project**

**Exhibit II  
Project Area  
and Surroundings**

Scale	1 : 40,000
Source	SoP and Field Visit
Drawing	W7E02DEE
Date	May 2007
Client	Engro Chemicals Pakistan Limited



**Exhibit III: Summary of Environmental and Social Impact of the Construction Phase**

<i>Potential Impact</i>	<i>Criteria for Determining Significance</i>	<i>Key Mitigations Measures</i>
<b>Environmental Issues</b>		
<b>Construction Noise</b> —Disturbance to surrounding communities of the proposed fertilizer plant due to operation of construction machinery on the plant site	The World Bank guidelines for noise.	Pre-construction noise survey; Reduce noise at source; Take noise levels in consideration during detailed design and construction planning; Reduce traffic noise; Use of noise abatement devices wherever practicable; All high noise activities to be conducted during day time
<b>Dust Emission</b> —Particulate matter emitted during construction activities can result in deterioration of ambient air quality in the vicinity of the source, and be a nuisance to the community.	An increase in visible dust beyond the boundaries of the construction site; or adverse impact on community assets, or community complaints	Sprinkling of water on unsealed surfaces; Use of wind shield around stockpiles; Vehicle speed restrictions; transportation of material in covered trucks; minimizing constructional activities near the settlements; ensuring that no stockpile is within 250 m of the community
<b>Vehicle and Equipment Exhaust</b> — Combustion exhaust from vehicles and construction can affect the ambient air quality of the project area	A significant impact on ambient air quality will be interpreted if the vehicles or equipment emit visible smoke	All vehicles, generators and other equipment used during the construction will be properly tuned and maintained in good working condition; The stack height of the generators will be at least 3 m above the ground
<b>Soil Contamination</b> —Oil and chemical spills can contaminate the soil	Presence of visible amount of hydrocarbon in soil	Provision of spill prevention and control kits, trays, and dykes; Use of impermeable surfaces in workshops, and storage areas; Contaminated soil will be collected and incinerated.
<b>Soil Erosion</b> —Erosion of soil can occur along the RoW due to wind or storm water run-off	A significant impact on soil stability will be interpreted if after completion of the construction activities the construction corridor is left with unsealed surfaces and the land is not graded to its natural or pre-project condition and drainage.	The corridor that is disturbed during pipeline construction will be kept to a minimum; The construction corridor along the pipeline's RoW will be properly marked; The movement of machinery will be restricted to the construction corridor; The top soil along the trench will be stockpiled separately, and will be used as the upper most soil layer during the back filling of the trench; Soil erosion control measures will be undertaken where necessary during construction

**Exhibit IV: Summary of Environmental and Social Impact of the Operation Phase**

<i>Potential Impact</i>	<i>Criteria for Determining Significance</i>	<i>Key Mitigation Measures</i>
<b>Environmental Issues</b>		
<b>Plant Noise</b> —Disturbance due to plant noise	The World Bank guidelines for noise	Currently the site is not meeting the WB guideline of 45 dB (A) of night time. As a mitigation measure sound barrier walls should be constructed as a part of this project.
<b>Emission</b> —Emission from the plant can potentially affect air quality.	NEQS and World Bank's ambient air and emission standards	No specific mitigation measures required as the emissions are within the standards set forth by the NEQS and the World Bank
<b>Accidental Release of Ammonia</b> —The accidental release of gas from the storage tanks, reservoirs, and pipeline containing ammonia can be a major health and safety risk for the nearby community	A significant impact will be interpreted if the receptors are exposed to ammonia concentrations that are injurious to health.	Site has been handling ammonia since 1968 and never had even a single major release occurred. Emergency response are well developed and in place. Release scenarios for the expanded plant will be developed, consequences in term of heat generation, over pressure and toxic release etc; Existing emergency response will be upgraded to accommodate requirement of expanded facility.
<b>Solid Waste Management</b> —The increased waste generated due to the proposed expansion can potentially affect the environment	Any person is exposed to potentially hazardous waste generated by the project; Project generates waste that can be avoided through practicable means; Non-recyclable and non-reusable waste ends up at any place other than the designated landfill site	Recyclable material will be separated at source; All hazardous waste will be separated from other wastes; Hazardous waste that cannot be disposed of through acceptable means will be stored in on-site storage facility until an isolated hazardous waste disposal facility is available

# Contents

---

<b>1. Introduction.....</b>	<b>1-1</b>
<b>1.1 Project Proponents.....</b>	<b>1-1</b>
<b>1.2 Project Overview.....</b>	<b>1-1</b>
<b>1.3 Project Area.....</b>	<b>1-2</b>
<b>1.4 Introduction of the EIA .....</b>	<b>1-2</b>
1.4.1 Objectives of the EIA.....	1-2
1.4.2 Scope of the EIA .....	1-2
1.4.3 Approach and Methodology .....	1-3
<b>1.5 Organization of this Report.....</b>	<b>1-4</b>
<b>2. Statutory Framework .....</b>	<b>2-1</b>
<b>2.1 Constitutional Provision .....</b>	<b>2-1</b>
<b>2.2 Environmental Laws .....</b>	<b>2-1</b>
2.2.1 Pakistan Environmental Protection Act 1997 .....	2-2
2.2.2 Other Environmental Laws.....	2-2
<b>2.3 Specific Requirements .....</b>	<b>2-3</b>
2.3.1 Environmental Assessment.....	2-3
2.3.2 National Environmental Quality Standards .....	2-4
<b>2.4 Requirement of the Equator Principles .....</b>	<b>2-5</b>
2.4.1 Social and Environmental Review Procedures .....	2-5
2.4.2 IFC Performance Standards on Social and Environmental Sustainability .....	2-6
2.4.3 World Bank Guidelines on Environment .....	2-8
<b>2.5 The Pakistan EPA’s Environmental Assessment Procedures.....</b>	<b>2-8</b>
<b>2.6 Target Standards .....</b>	<b>2-9</b>
<b>3. Project Description.....</b>	<b>3-1</b>
<b>3.1 Project Background.....</b>	<b>3-1</b>
<b>3.2 New Development.....</b>	<b>3-1</b>
<b>3.3 Project Location.....</b>	<b>3-1</b>
<b>3.4 Existing Plant Facilities and Operations .....</b>	<b>3-2</b>
3.4.1 Existing Gas Pipelines .....	3-3
3.4.2 Operational Controls .....	3-3
3.4.3 Power Supply.....	3-3

3.4.4	Existing Off-site Facility .....	3-3
<b>3.5</b>	<b>Proposed Development Project.....</b>	<b>3-3</b>
3.5.1	Proposed Ammonia Plant .....	3-4
3.5.2	Proposed Urea Plant.....	3-7
3.5.3	Natural Gas Pipeline .....	3-9
3.5.4	Employment .....	3-11
<b>3.6</b>	<b>Expansion Project Construction Activities .....</b>	<b>3-11</b>
3.6.1	Plant Installation.....	3-12
3.6.2	Construction Camps.....	3-13
3.6.3	Equipment .....	3-14
3.6.4	Construction Material Sourcing.....	3-14
3.6.5	Waste Streams.....	3-14
3.6.6	Site Restoration.....	3-15
3.6.7	Construction Schedule .....	3-15
<b>4.</b>	<b>Description of Environment .....</b>	<b>4-1</b>
<b>4.1</b>	<b>Natural Environment.....</b>	<b>4-1</b>
4.1.1	Topography, Geology, and Soils.....	4-1
4.1.2	Seismicity of the Project Area .....	4-2
4.1.3	Water Resources .....	4-2
4.1.4	Climate and Air Quality .....	4-3
4.1.5	Ambient Air Quality .....	4-4
<b>4.2</b>	<b>Description of Natural Environment .....</b>	<b>4-4</b>
4.1.6	Flora .....	4-4
4.1.7	Fauna.....	4-5
<b>4.3</b>	<b>Socioeconomic Environment .....</b>	<b>4-5</b>
4.3.1	Administrative Setup .....	4-5
4.3.2	Population .....	4-6
4.3.3	Housing.....	4-6
4.3.4	Tribes .....	4-6
4.3.5	Community Livelihood.....	4-7
4.3.6	Drinking Water .....	4-7
4.3.7	Health.....	4-7
4.3.8	Education .....	4-8
4.3.9	Infrastructure .....	4-8
4.3.10	Gender Analysis.....	4-8
4.3.11	Cultural and Archeological Resources .....	4-9
<b>5.</b>	<b>Analysis of Alternatives.....</b>	<b>5-1</b>
<b>5.1</b>	<b>Management Options .....</b>	<b>5-1</b>

5.1.1	No-Action .....	5-1
<b>5.2</b>	<b>Alternative Technology Options.....</b>	<b>5-1</b>
5.2.1	Salient Features of the Selected Option .....	5-1
<b>6.</b>	<b>Stakeholder Consultation .....</b>	<b>6-1</b>
6.1	Objectives of Stakeholder Consultation.....	6-1
6.2	Identification of Stakeholders.....	6-1
6.3	Stakeholder Consultation Process .....	6-1
6.4	Primary Stakeholders Consultation .....	6-2
6.4.1	Topics for Discussion .....	6-2
6.4.2	Outcomes of Consultations .....	6-2
6.5	Meetings with Secondary Stakeholders .....	6-3
6.5.1	Consultation with Mari Gas Company Limited (MGCL).....	6-3
6.5.2	Consultation with Governmental Institutions and Community Representatives .....	6-3
6.5.3	Consultation with NGOs and CBOs .....	6-5
6.5.4	Consultation with Industries .....	6-6
<b>7.</b>	<b>Environmental Impacts and Mitigations .....</b>	<b>7-1</b>
7.1	Scoping.....	7-1
7.2	Impact Assessment Methodology.....	7-2
7.3	Impacts Associated with Construction Activities.....	7-4
7.3.1	Construction Noise.....	7-4
7.3.2	Dust Emission .....	7-7
7.3.3	Vehicle and Equipment Exhaust .....	7-8
7.3.4	Soil erosion .....	7-9
7.3.5	Soil Contamination .....	7-11
7.4	Impacts Associated with Plant Operations .....	7-12
7.4.1	Plant Noise.....	7-13
7.4.2	Emissions.....	7-14
7.4.3	Effluents .....	7-15
7.4.4	Accidental Release of Ammonia .....	7-16
7.4.5	Solid Waste Management.....	7-18
7.4.6	Cultural Resources.....	7-21
7.4.7	Carbon Emission Reductions.....	7-21
7.5	Environmental Impact of Plants Decommissioning .....	7-22

**8. Conclusion.....8-1**  
**9. References .....9-1**

**Appendices**

**Appendix A: National Environmental Quality Standards**

**Appendix B: Ambient Air Quality Measurement Results**

**Appendix C: Flora and Fauna**

**Appendix D: Environmental Management Plan**

**Appendix E: Ambient Noise Modeling**

**Appendix F: Air Dispersion Modeling**

**Appendix G: Accidental Release of Ammonia**

## Exhibits

---

<b>Exhibit 1.1:</b>	Project Location .....	<b>1-5</b>
<b>Exhibit 1.2:</b>	Project Area and Surroundings.....	<b>1-6</b>
<b>Exhibit 2.1:</b>	Target Emission Standards.....	<b>2-10</b>
<b>Exhibit 2.2:</b>	Target Ambient Air Quality Standards.....	<b>2-10</b>
<b>Exhibit 2.3:</b>	Target Effluent Standards .....	<b>2-11</b>
<b>Exhibit 3.1:</b>	Layout of the Existing Plant.....	<b>3-16</b>
<b>Exhibit 3.2:</b>	Total Liquid Effluents Produced .....	<b>3-17</b>
<b>Exhibit 3.3:</b>	Total Solid Waste Produced.....	<b>3-17</b>
<b>Exhibit 3.4:</b>	Construction Wastes .....	<b>3-18</b>
<b>Exhibit 4.1:</b>	Seasonal Characteristics of Climate of the Project Area .....	<b>4-10</b>
<b>Exhibit 4.2:</b>	Monthly Temperature Data for Sukkur (in °C).....	<b>4-11</b>
<b>Exhibit 4.3:</b>	Mean Monthly Relative Humidity at Sukkur .....	<b>4-11</b>
<b>Exhibit 4.4:</b>	Demographic Data of the Study Area .....	<b>4-12</b>
<b>Exhibit 4.5:</b>	Agricultural Field in the Project Area.....	<b>4-12</b>
<b>Exhibit 4.6:</b>	Rural Settlement in the Project Area.....	<b>4-13</b>
<b>Exhibit 4.7:</b>	Administrative Association of Settlements in the Study Area.....	<b>4-13</b>
<b>Exhibit 4.8:</b>	Sources of Income in the Study Area.....	<b>4-14</b>
<b>Exhibit 4.9:</b>	Health and Education Profile Map.....	<b>4-15</b>
<b>Exhibit 4.10:</b>	Literacy Profile and Educational Services of the Project Area .....	<b>4-16</b>
<b>Exhibit 4.11:</b>	Community Access to Media.....	<b>4-16</b>
<b>Exhibit 6.1:</b>	List of Participants of Primary Stakeholders Consultation .....	<b>6-7</b>
<b>Exhibit 6.2:</b>	Primary Stakeholders Being Consulted .....	<b>6-7</b>
<b>Exhibit 6.3:</b>	Concerns Raised by Stakeholders and Mitigation .....	<b>6-8</b>
<b>Exhibit 6.4:</b>	List of Secondary Stakeholders and Participants.....	<b>6-9</b>
<b>Exhibit 6.5:</b>	Consultation with Secondary Stakeholders In-progress .....	<b>6-10</b>
<b>Exhibit 6.6:</b>	Summarized Outcomes of the Stakeholder Consultation .....	<b>6-11</b>
<b>Exhibit 7.1:</b>	World Bank Recommended Noise Levels.....	<b>7-23</b>
<b>Exhibit 7.2:</b>	WHO Guideline Values for Community Noise in Specific Environments.....	<b>7-23</b>

<b>Exhibit 7.3:</b>	Construction Equipment Noise Ranges .....	<b>7-24</b>
<b>Exhibit 7.4:</b>	Results of Air Dispersion Modeling .....	<b>7-25</b>
<b>Exhibit 7.5:</b>	Increase in Ambient Concentration .....	<b>7-25</b>
<b>Exhibit 7.6:</b>	Ammonia Exposure Threshold Levels .....	<b>7-26</b>
<b>Exhibit 7.7:</b>	AFTOX model Input Parameters.....	<b>7-26</b>
<b>Exhibit 7.8:</b>	AFTOX Results of Accidental Releases of Ammonia .....	<b>7-27</b>
<b>Exhibit 7.9:</b>	Normalized Accident Rates for United States, 1994-1999.....	<b>7-27</b>

# 1. Introduction

---

Engro Chemical Pakistan Limited (ECPL) plans to enhance its existing urea manufacturing capacity by setting up a new world scale Ammonia Urea complex within its existing facility in Daharki Sindh. The subject installations will be state-of-the-art and the most environment friendly in the country. The proposed project will increase the existing annual production of 975 kilotons (KT) of Urea by 1,267 KT resulting in a total annual production of 2,242 KT.

To facilitate the increase in production of urea, expansion in the existing utilities of the plant will also be undertaken. The new facilities will be installed adjacent to the existing ECPL facility. A new offsite facility will also be built to supply canal water and well water to the plant site and additional housing will be constructed for the additional staff (see **Exhibit 1.1**).

## 1.1 Project Proponents

ECPL is the second largest producer of urea fertilizer in Pakistan. The company was incorporated in 1965 and was formerly Exxon Chemical Pakistan Limited until 1991, when Exxon decided to divest their fertilizer business on a global basis and sold off its equity of 75% shares. The Employees of Engro, in partnership with leading international and local financial institutions bought out Exxon's equity and the company was renamed as Engro Chemical Pakistan Limited. Engro is a public limited company listed on the Stock Exchanges of Karachi, Lahore and Islamabad. ECPL since then has diversified its business and invested in several other sectors, both independently and as joint ventures with other companies. These businesses include polyvinyl chloride (PVC) manufacturing, chemical and LPG marine offloading and storage facility, NPK fertilizer manufacturing, milk and dairy products, and industrial automation. Recently ECPL has also entered into the field of power generation and is about to start construction of a thermal power plant. The power plant will be owned and operated by Engro Energy Limited (EEL) a company that is fully owned by ECPL.

## 1.2 Project Overview

The proposed project comprises of setting up the above mentioned units. Natural gas for the project will be supplied by SNGPL via a 35-km long gas pipeline at the rate of 100 million standard cubic feet per day (MMSCFD) from the Oil and Gas Development Company Limited (OGDCL) operated Qadirpur Gas Field.

The proponents intend to acquire financing for this project from various leading financing institutions. These institutions have adopted the 'Equator Principles'<sup>1</sup> to manage the

---

<sup>1</sup> The Equator Principles is a set of voluntary environmental and social guidelines for ethical project finance. These principles commit banks and other signatories to not finance projects that fail to meet these

social and environmental issues in project financing. Among other things, the principle requires that the projects should follow the environmental guidelines of the World Bank and the International Finance Corporation (IFC). This report has been prepared to meet the requirements of the Equator Principle.

### 1.3 Project Area

The project area refers to the geographical area in which the activities related to the construction and operation of the plant are proposed to take place and in which the environmental impact of the activities are likely to happen. Unless otherwise specified or implied by context, the term ‘project area’ will refer to the area within 2 km of the proposed site of the plant and 500 m on either side of the import gas supply pipeline. The project area and its surroundings are shown in **Exhibit 1.2**.

### 1.4 Introduction of the EIA

#### 1.4.1 Objectives of the EIA

The objectives of this EIA are to:

- ▶ Assess the existing environmental conditions in the project area, including the identification of environmentally sensitive areas
- ▶ Assess the proposed activities to identify their potential impacts, evaluate the impacts, and determine their significance
- ▶ Propose appropriate mitigation and monitoring measures that can be incorporated into the design of the proposed activities to minimize any damaging effects or any lasting negative consequences identified by the assessment
- ▶ Assess the proposed activities and determine whether they comply with the relevant environmental regulations in Pakistan
- ▶ Prepare an EIA report for submittal to the Sindh Environmental Protection Agency (SEPA) and the project financing institutions.

#### 1.4.2 Scope of the EIA

This EIA covers assessment of the physical, biological, and socioeconomic impact of the following:

- ▶ Construction activities including the setting up of new units and the expansion of existing auxiliary utilities at the proposed site
- ▶ Relevant off-site construction activities including the import pipeline and offsite water intake facility
- ▶ Operation of the complete facility after expansion

---

guidelines. The principles were conceived in 2002 on an initiative of the International Finance Corporation and launched in 2003.

- ▶ Decommissioning of the plant.

### **1.4.3 Approach and Methodology**

The EIA was performed in four main phases, which are described below.

#### **Scoping**

The key activities of this phase included:

*Project Data Compilation:* A generic description of the proposed activities relevant to environmental assessment was compiled with the help of the proponent.

*Published Literature Review:* Secondary data on weather, soil, water resources, wildlife, and vegetation were reviewed and compiled.

*Legislative Review:* Information on relevant legislation, regulations, guidelines, and standards was reviewed and compiled.

*Identification of Potential Impacts:* The information collected in the previous steps was reviewed and potential environmental issues identified.

#### **Baseline Data Collection**

A considerable amount of baseline information on the project area was available from existing literature and other studies conducted close to the project area. A field visit was conducted to collect primary data on the proposed site alternatives of the fertilizer plant.

#### **Impact Assessment**

The environmental, socioeconomic, and project information collected was used to assess the potential impacts of the proposed activities. The issues studied included potential project impacts on:

- ▶ Geomorphology
- ▶ Groundwater and surface water quality, with particular reference to the coast
- ▶ Ambient air quality and ambient noise levels
- ▶ The ecology of the area, including flora and fauna especially the marine ecosystem
- ▶ Local communities.

Wherever possible and applicable, the discussion covers the following aspects:

- ▶ The present baseline conditions
- ▶ The potential change in environmental parameters likely to occur by project related activities
- ▶ The identification of potential impacts
- ▶ The evaluation of the likelihood and significance of potential impacts
- ▶ The defining of mitigation measures to reduce impacts to as low as practicable

- ▶ The prediction of any residual impacts, including all long-term and short-term, direct and indirect, and beneficial and adverse impacts
- ▶ The monitoring of residual impacts.

### **Documentation**

This report documenting the EIA process and results is prepared according to the relevant guidelines set by the Pakistan Environmental Protection Agency (Pak-EPA) and the IFC.

## **1.5 Organization of this Report**

**Section 2** (*Policy, Statutory, and Institutional Framework*) briefly discusses existing national policy and resulting legislation for sustainable development and environmental protection, and then presents the legislative requirements that need to be followed while conducting an EIA.

**Section 3** (*Project Description*) describes the proposed Fertilizer Expansion Project

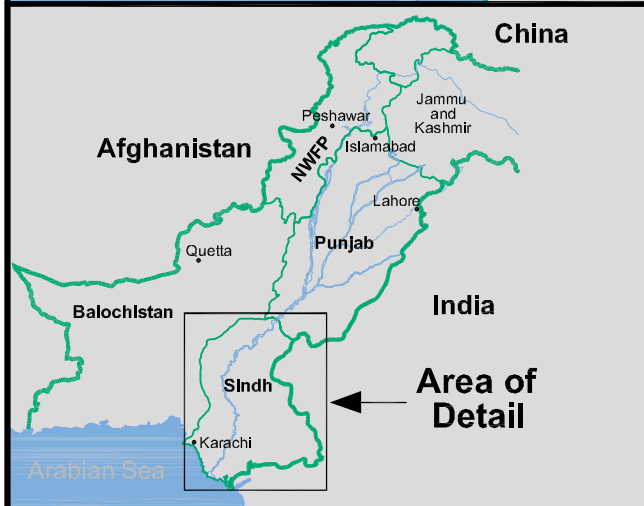
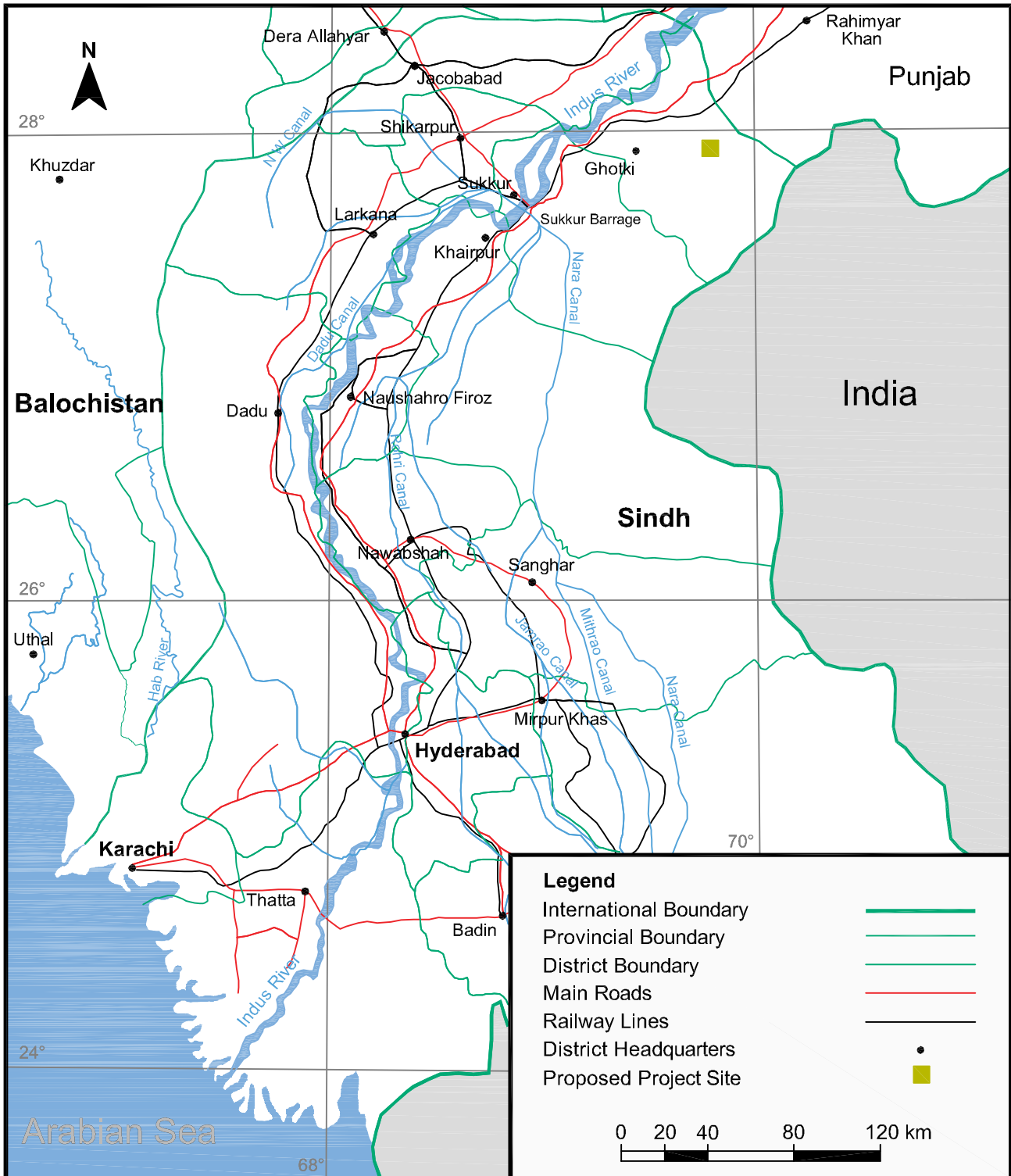
**Section 4** (*Description of the Environment*) details the project area's existing physical, biological, and socioeconomic condition, including geomorphology and soils, water resources, and air quality, flora and fauna, and demography.

**Section 5** (*Analyses of Alternatives*) presents the project alternatives that were considered, and the reasons for their selection or rejection.

**Section 6** (*Stakeholder Consultations*) presents the view point of primary & secondary stake holders associated with the project

**Section 7** (*Project Impacts and Mitigation*) presents an assessment of the project's impact and their required mitigation measures to the physical, biological, and socioeconomic environment.

Finally, in **Section 8** (*Conclusion*) the conclusions of the projects are summarized, followed by **Section 9** (*References*).



**Legend**

- International Boundary ———
- Provincial Boundary ———
- District Boundary ———
- Main Roads ———
- Railway Lines ———
- District Headquarters •
- Proposed Project Site ■

0 20 40 80 120 km

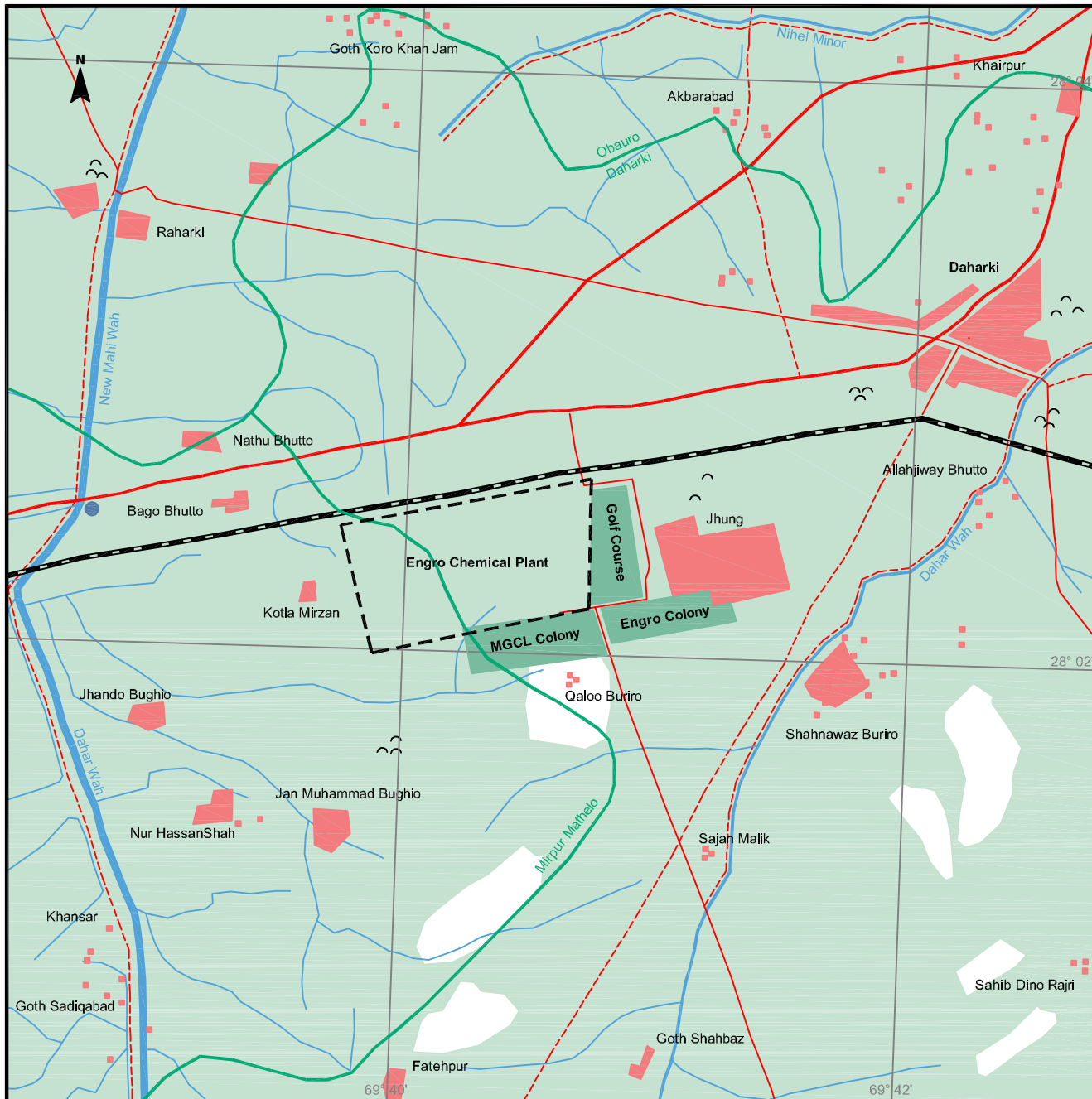
**EIA of ECPL Expansion Project**

**Exhibit 1.1**

**Project Location**

<b>Scale</b>	1 : 2,750,000
<b>Source</b>	Survey of Pakistan
<b>Drawing</b>	W6E01DEE
<b>Date</b>	May 2007
<b>Client</b>	Engro Chemicals Pakistan Limited

**Hagler Bailly Pakistan**



- Legend**
- Highway
  - Metalled Road
  - Jeepable Track / Trail
  - Railway Line
  - Taluka Boundary
  - Canals
  - Settlement
  - Graveyard
  - Offsite Water Facility



**EIA of ECPL Expansion Project**

**Exhibit 1.2  
Project Area  
and Surroundings**

Scale	1 : 40,000
Source	SoP and Field Visit
Drawing	W7E02DEE
Date	May 2007
Client	Engro Chemicals Pakistan Limited



## 2. Statutory Framework

---

‘Sustainable development’ is a concept that has emerged over the past three decades to describe a new framework aimed at economic and social development while maintaining the long-term integrity of the ecological system. The principles of sustainable development are in the process of being incorporated into national policies and legislation in Pakistan through various statutory instruments. This chapter describes the current legal responsibilities of the proponent in the context of the environment and sustainable development, and the institutions that exist in the country that may influence the environmental management of the proposed project.

### 2.1 Constitutional Provision

According to the Constitution of Pakistan, the legislative powers lie with the federal parliament and the legislative assemblies of the four provinces of Pakistan. The Fourth Schedule of the constitution provides two lists of issues. One list, the *Federal Legislative List*, includes issues on which only the federal government has legislative powers. The second list, the *Concurrent Legislative List* includes issues on which both the federal and the provincial governments have legislative powers. If a particular legislation passed by a provincial assembly comes into conflict with a law enacted by the national assembly, then according to the constitution, the federal legislation will prevail over the provincial legislation to the extent of the inconsistency.

The subject of ‘environmental pollution and ecology’ is included in the concurrent list of the constitution. Thus, allowing both the federal and provincial governments to enact laws on the subject. To date, only the federal government has enacted laws on environment, and the provincial environmental institutions derive their power from federal law.

Article 9 of the constitution defines the right to life as a fundamental right in these words “No person shall be deprived of life or liberty save in accordance with law”. The Supreme Court of Pakistan in its judgment in the case *Shehla Zia and others vs WAPDA* (1994) declared that the right to a clean environment is part of the fundamental constitutional right to life.

### 2.2 Environmental Laws

The definition of environmental law can be derived from the legal definition of ‘environment’. In Section 2(x) of the Pakistan Environmental Protection Act 1997 (PEPA 1997) environment is defined to include air, water, land and layers of the atmosphere; living organisms and inorganic matter; the ecosystem and ecological relationships; buildings, structures, roads, facilities and works; social and economic conditions affecting community life; and the interrelationship between these elements. From this definition, an environmental law can be considered to include all laws that are

designed to, or that directly or indirectly affect, the management of natural resources including the control of pollution of these natural resources.

By this definition, environmental laws include a) laws that have been specifically enacted to protect the environment such as the PEPA 1997, and b) laws relating to subject such as forest, water resources, wildlife, land, agriculture, health, and town planning.

### **2.2.1 Pakistan Environmental Protection Act 1997**

The PEPA 1997 is the basic legislative tool empowering the government to frame regulations for the protection of the environment. The act is applicable to a broad range of issues and extends to air, water, soil, marine, and noise pollution, as well as to the handling of hazardous wastes. A number of rules and regulations have been promulgated under the PEPA 1997. These are below.

- ▶ Environmental Samples Rules 2001
- ▶ Pollution Charge for Industry (Calculation and Collection) Rules 2001
- ▶ Provincial Sustainable Development Fund Board (Procedure) Rules 2001
- ▶ National Environmental Quality Standards (Certification of Environmental Laboratories) Regulations 2000
- ▶ The National Environmental Quality Standard (Self-Monitoring and Reporting by Industry) Rule 2001
- ▶ Pakistan Environmental Protection Agency Review of IEE and EIA Regulations 2000
- ▶ National Environmental Quality Standards

### **2.2.2 Other Environmental Laws**

There is a long list of laws that fall in the category of environmental law. Some of the most relevant laws are listed below.

- ▶ Forest Act 1927
- ▶ Fisheries Act 1897
- ▶ Wildlife protection, preservation, conservation and management laws
- ▶ The Antiquities Act 1975
- ▶ Canal and Drainage Act 1873
- ▶ Boilers Act, 1923
- ▶ West Pakistan Boiler Rules, 1951
- ▶ Land Acquisition Act 1894
- ▶ Agricultural Pesticide Ordinance 1971
- ▶ Petroleum Act 1934
- ▶ Mines Act 1923

- ▶ Factories Act 1934
- ▶ Motor Vehicle Ordinance 1965
- ▶ Dangerous Cargoes Act 1953
- ▶ Pakistan Nuclear Regulatory Authority Ordinance 2001
- ▶ Electricity Act 1910
- ▶ Pakistan Plant Quarantine Act 1976
- ▶ Pakistan Penal Code 1860
- ▶ Explosives Act 1884

## 2.3 Specific Requirements

### 2.3.1 Environmental Assessment

Section 12(1) of the PEPA 1997 requires that “No proponent of a project shall commence construction or operation unless he has filed with the Federal Agency an initial environmental examination or, where the project is likely to cause an adverse environmental effect, an environmental impact assessment, and has obtained from the Federal Agency approval in respect thereof.”

The *Pakistan Environmental Protection Agency Review of Initial Environmental Examination and Environmental Impact Assessment Regulations, 2000* (IEE-EIA Regulations 2000) provide the necessary details on the preparation, submission, and review of the IEE and the EIA. The regulation categorizes the projects on the basis of anticipated degree of environmental impact. Project types that are likely to have significant adverse impact are listed in Schedule II of the regulations and require an EIA. Project that are not likely to have significant adverse impact, are listed in Schedule I and require an IEE to be conducted, rather than a full-fledged EIA, provided that the project is not located in an environmentally sensitive area. Other features of the IEE-EIA Regulations 2000 relevant to the proposed project are listed below.

1. A fee is payable to the EPA for review of the EIA or IEE.
2. The EPA is bound to conduct a preliminary scrutiny and reply within 10 days of the submittal of the report a) confirming completeness, or b) asking for additional information, if needed, or c) returning the report requiring additional studies, if necessary.
3. The EPA is required to make every effort to complete the EIA review process within 90 days of the issue of confirmation of completeness.
4. The EIA approval is valid for three years from the date of accord.

For this project:

- ▶ ‘Federal Agency’ refers to the Sindh Environmental Protection Agency (SEPA)

- ▶ The proposed project as per its categorization, in accordance with the Pakistan Environmental Protection Act, 1997 and IEE-EIA Regulations 2000, requires an EIA.

### **2.3.2 National Environmental Quality Standards**

Section 11(1) of the Act states that “Subject to the provisions of this Act and the rules and regulations made there under, no person shall discharge or emit, or allow the discharge or emission of, any effluent or waste or air pollutant or noise in an amount, concentration, or level which is in excess of the National Environmental Quality Standards.” The Pakistan Environmental Protection Agency has published National Environmental Quality Standards (NEQS) that will be applicable to the proposed project. The NEQS were first promulgated in 1993 and were amended in 1995 and 2000.

The NEQS for liquid effluents discharged to inland waters and gaseous emission from industrial sources as applicable to the project are provided in **Appendix A**.

#### ***The Sindh Wildlife Protection Ordinance, 1972***

The Sindh Wildlife Protection Ordinance, 1972 empowers the government to declare certain areas reserved for the protection of wildlife and control activities within these areas. It also provides protection to endangered species of wildlife. As no activities are planned in declared protected areas, no provision of this law is applicable to the proposed project.

#### ***The Sindh Fisheries Ordinance, 1980***

The Sindh Fisheries Ordinance, 1980 regulates fishing in the public waters, including the coastal areas, of Sindh. It empowers the government of Sindh to issue licenses for fishing in public waters, put restriction on the type of equipment that can be used for fishing, restrict fishing in certain areas or of certain species of fish, regulate the onshore trade of fish catch, and regulate the fish processing industry. Article 8 of the Ordinance prohibits the discharge of wastewater to public waters without the consent of the Director Fisheries. A copy of the EIA report will be sent to the Director Fisheries, Government of Sindh for his consent when the report is submitted to the SEPA for environmental approval.

#### ***The Forest Act, 1927***

The Forest Act, 1927 empowers the government to declare certain areas reserved forest. As no reserved forest exists in the vicinity of the proposed project, the provisions of this law are not applicable to the proposed project.

#### ***Hazardous Substance Rules, 2003 (Draft)***

Section 14 of the PEPA 1997 requires that “no person shall generate, collect, consign, transport, treat, dispose of, store, handle or import any hazardous substance except (a) under a license issued by the Federal Agency and in such manner as may be prescribed; or (b) in accordance with the provisions of any other law for the time being in force, or of any international treaty, convention, protocol, code, standard, agreement or

other instrument to which Pakistan is a party.” Pak-EPA has drafted the Hazardous Substance Rules to implement the licensing requirement. The rules are still in their draft form and are pending notification.

### ***The Antiquities Act, 1975 and the Sindh Cultural Heritage (Preservation) Act, 1994***

The Antiquities Act of 1975 ensures the protection of Pakistan’s cultural resources. The Act defines ‘antiquities’ as ancient products of human activity, historical sites, or sites of anthropological or cultural interest, national monuments, etc. The Act is designed to protect these antiquities from destruction, theft, negligence, unlawful excavation, trade, and export. The law prohibits new construction in the proximity of a protected antiquity and empowers the Government of Pakistan to prohibit excavation in any area that may contain articles of archaeological significance. Under the Act, the project proponents are obligated to ensure that no activity is undertaken within 61 m (200 ft) of a protected antiquity, and to report to the Department of Archaeology, Government of Pakistan any archaeological discovery made during the course of the project.

The Sindh Cultural Heritage (Preservation) Act, 1994 is the provincial law for the protection of cultural heritage. Its objectives are similar to those of the Antiquity Act, 1975. No antiquity protected under these two laws was identified in the vicinity of the proposed project.

## **2.4 Requirement of the Equator Principles**

The Equator Principles require that all projects funded under these principles to be constructed and operated in an environmentally responsible manner. All projects that receive funding from signatories of the equator principles must therefore comply with appropriate World Bank/IFC environmental policies and guidelines. As the project proponents are likely to seek funding under these principles for the proposed expansion project, the EIA has been carried out to comply with both national and IFC guidelines. The key documents of the IFC are discussed below.

### **2.4.1 Social and Environmental Review Procedures**

IFC’s Environment and Social Review Procedure (ESRP) outlines the process through which IFC staff implement the Corporation’s commitment to promoting projects that are environmentally and socially sustainable. This commitment is a fundamental part of IFC’s mission and is elaborated on in IFC’s Policy and Performance Standards on Social and Environment Sustainability (PPS) as well as in IFC’s Policy on Disclosure of Information (the Disclosure Policy). The ESRP applies to the full range of IFC’s investment activities: direct lending to private enterprises (including both corporate and project finance); lending to financial intermediaries; minority equity/shareholding in companies, financial institutions, and other entities; structured finance products (guarantees, securitizations); and municipal finance. The ESRP also describes IFC’s approach to its technical assistance and advisory activities, including both investment-related work and capacity building to help support private sector development in emerging markets. The ESRP also describes the application methodology that IFC staff must follow in order to implement IFC’s institutional disclosure requirements in

accordance with the Disclosure Policy. The application of the PPS varies according to the nature of IFC's intervention with the client and the nature of the client's business (for example, industrial companies versus financial institutions). The ESRP covers IFC's review and supervision responsibilities for environmental and social performance throughout the project life cycle.

The timing of an IFC investment in relation to a client's business activities and project implementation process varies from project to project. IFC does not control the timing of its entry into a project; IFC's engagement, more times than not, occurs well after the project is conceived, with the site selected and development started. When considering whether or not to participate in a transaction, IFC's review takes into account any project development work undertaken beforehand. IFC has a range of other tools to help staff assist its clients in improving the environment and social outcomes of their projects. Other sources of information that complement the PPS include the Guidance Notes for the Performance Standards; IFC Environmental Health and Safety Guidelines, which provide specific benchmark criteria in line with good international practice; and a diverse range of best practice material. The ESRP therefore does not provide technical support or guidance for specific environmental and social issues. Instead it is a defined and structured process that helps IFC maintain consistency and quality of its review process and ensure that policy requirements are identified and committed to. It thus helps fulfill the Corporation's commitment to sustainable outcomes in the operations it invests in or supports. Assessing and managing environmental and social impacts in a manner consistent with the PPS is the responsibility of the client. IFC's responsibility is to review the work of the client, identify opportunities to improve outcomes, and ensure consistency with policy requirements. IFC's approach is to take full advantage of any work undertaken by the client before IFC's own entry into the transaction, thus minimizing additional processing burdens where it is possible to do so while still meeting the Corporation's policy requirements. Of particular importance in the PPS is the adequacy of the client's ESMS. IFC's investment or advisory support is used to influence and improve performance whenever possible.

The ESRP includes an amended categorization methodology, which categorizes projects according to potential adverse impacts after IFC's review rather than during initial screening. Categorization was previously used as a determinant of certain procedural requirements for the client relating to assessment, community engagement and disclosure. The ESRP recognizes that all process requirements of the client have now been captured in the PPS and that categorization is now used only to determine IFC's institutional disclosure requirements. IFC's environmental and social specialists are essential and integral parts of the process the Corporation uses to optimize outcomes. The ESRP is not a substitute for professional judgment and expertise but provides a framework for the consideration and documentation of key issues and decisions that are made during the project cycle. It also provides staff with a process for document preparation.

#### **2.4.2 IFC Performance Standards on Social and Environmental Sustainability**

IFC applies the Performance Standards to manage social and environmental risks and impacts and to enhance development opportunities in its private sector financing in its

member countries eligible for financing<sup>1</sup>. The Performance Standards may also be applied by other financial institutions electing to apply them to projects in emerging markets. Together, the eight Performance Standards establish standards that the client<sup>2</sup> is to meet throughout the life of an investment by IFC or other relevant financial institution:

Performance Standard 1: Social and Environmental Assessment and Management System

Performance Standard 2: Labor and Working Conditions

Performance Standard 3: Pollution Prevention and Abatement

Performance Standard 4: Community Health, Safety and Security

Performance Standard 5: Land Acquisition and Involuntary Resettlement

Performance Standard 6: Biodiversity Conservation and Sustainable Natural Resource Management

Performance Standard 7: Indigenous Peoples

Performance Standard 8: Cultural Heritage

Performance Standard 1 establishes the importance of: (i) integrated assessment to identify the social and environmental impacts, risks, and opportunities of projects; (ii) effective community engagement through disclosure of project-related information and consultation with local communities on matters that directly affect them; and (iii) the client's management of social and environmental performance throughout the life of the project. Performance Standards 2 through 8 establish requirements to avoid, reduce, mitigate or compensate for impacts on people and the environment, and to improve conditions where appropriate. While all relevant social and environmental risks and potential impacts should be considered as part of the assessment, Performance Standards 2 through 8 describe potential social and environmental impacts that require particular attention in emerging markets. Where social or environmental impacts are anticipated, the client is required to manage them through its Social and Environmental Management System consistent with Performance Standard 1.

In addition to meeting the requirements under the Performance Standards, clients must comply with applicable national laws, including those laws implementing host country obligations under international law.

A set of Guidance Notes, corresponding to the Performance Standards, offers helpful guidance on the requirements contained in the Performance Standards, including reference materials, and on good sustainability practices to help clients improve project performance.

---

<sup>1</sup> IFC will apply the Performance Standards to projects it finances, consistent with the provisions in the accompanying IFC's Policy on Social and Environmental Sustainability. IFC's institutional disclosure of information will be pursuant to IFC's Policy on Disclosure of Information.

<sup>2</sup> The term "client" is used throughout the Performance Standards broadly to refer to the party responsible for implementing and operating the project that is being financed, or the recipient of the financing, depending on the project structure and type of financing. The term "project" is defined in Performance Standard 1.

### 2.4.3 World Bank Guidelines on Environment

The Pak-EPA recommends using World Bank (WB) environmental guidelines for areas where there may be a gap in the national guidelines. The principal World Bank publications that contain environmental guidelines are listed below.

- ▶ World Bank Group Environmental, Health, and Safety Guidelines (known as the 'EHS Guidelines') 2007<sup>3</sup>
- ▶ Pollution Prevention and Abatement Handbook 1998: Towards Cleaner Production<sup>4</sup>
- ▶ Environmental Assessment Sourcebook, Volume I: Policies, Procedures, and Cross-Sectoral Issues<sup>5</sup>
- ▶ Environmental Assessment Sourcebook, Volume II: Sectoral Guidelines<sup>6</sup>

## 2.5 The Pakistan EPA's Environmental Assessment Procedures

The Federal EPA has published a set of environmental guidelines for conducting environmental assessments and the environmental management of different types of development projects. The guidelines that are relevant to the proposed project are listed below, followed by comments on their relevance to the proposed project:

- ▶ *Policy and Procedures for Filing, Review and Approval of Environmental Assessments*, Pakistan Environmental Protection Agency, September 1997

These guidelines define the policy context and the administrative procedures that will govern the environmental assessment process, from the project pre-feasibility stage, to the approval of the environmental report. The section on administrative procedures has been superseded by the IEE-EIA Regulations, 2000.

- ▶ *Guidelines for the Preparation and Review of Environmental Reports*, Pakistan Environmental Protection Agency, 1997

The guidelines on the preparation and review of environmental reports target the project proponents and specify:

- ▷ The nature of the information to be included in environmental reports
- ▷ The minimum qualifications of the EIA conductors appointed
- ▷ The need to incorporate suitable mitigation measures at every stage of project implementation
- ▷ The need to specify monitoring procedures.

<sup>3</sup> These guidelines released in April 2007, replace those documents previously published in Part III of the Pollution Prevention and Abatement Handbook and on the IFC website.

<sup>4</sup> World Bank, UNIDO, and UNEP. 1999. *Pollution Prevention and Abatement Handbook, Towards Cleaner Production*. Environment Department, The World Bank; UNIDO; UNEP.

<sup>5</sup> World Bank. 1991. *Environmental Assessment Sourcebook, Volume I, Policies, Procedures, and Cross-Sectoral Issues*. World Bank Technical Paper No. 139. Environment Department, The World Bank.

<sup>6</sup> World Bank. 1991. *Environmental Assessment Sourcebook, Volume III, Sectoral Guidelines*. World Bank Technical Paper No. 140. Environment Department, The World Bank

The terms of reference for the reports are to be prepared by the project proponents themselves. The report must contain baseline data on the project area, detailed assessment thereof, and mitigation measures.

- ▶ *Guidelines for Public Consultation*, Pakistan Environmental Protection Agency, May, 1997

This guideline supports the two guidelines mentioned earlier. It deals with possible approaches to public consultation and techniques for designing an effective program of consultation that reaches out to all major stakeholders and ensures the incorporation of their concerns in any impact assessment study.

## **2.6 Target Standards**

The target standards for the gaseous emissions, ambient air quality, and liquid effluent for the proposed project are based on the NEQS and the World Bank Guidelines. The relevant parameters are shown in **Exhibits 2.1 to 2.3**.

**Exhibit 2.1: Target Emission Standards**

<i>Parameter</i>	<i>Source</i>	<i>Units</i>	<i>Target Standard</i>
Nitrogen oxides	NEQS	mg/Nm <sup>3</sup>	400
	WB*	mg/Nm <sup>3</sup>	300
Ammonia	WB*	mg/Nm <sup>3</sup>	50
Urea	WB*	mg/Nm <sup>3</sup>	50
Sulfur oxides	NEQS	mg/Nm <sup>3</sup>	1,700
Particulate Matter	WB	mg/Nm <sup>3</sup>	50

\* mg/Nm<sup>3</sup> (dry, 15% O<sub>2</sub>)

**Exhibit 2.2: Target Ambient Air Quality Standards**

<i>Parameter<sup>a</sup></i>	<i>Averaging Period</i>	<i>Target Limits (µg/m<sup>3</sup>)</i>
Sulfur dioxide	Annual	80
	24-hr	150
Nitrogen oxides	Annual	100
Carbon Monoxide	1-hr	40,000
Particulate Matter	Annual	80
	24-hr	230

<sup>a</sup> based on the World Bank Guidelines except that of Carbon Monoxide, which is from United States National Ambient Air Quality Standards

**Exhibit 2.3: Target Effluent Standards**

<i>Parameter</i>	<i>Unit</i>	<i>WB Guidelines</i>	<i>NEQS Limits</i>	<i>Target Limit</i>
pH		6-9	6-9	6-9
Suspended solids	mg/l	50	200	50
Biological Oxygen Demand (BOD <sub>5</sub> )	mg/l		80	80
Chemical Oxygen Demand (COD)	mg/l		150	150
Total Dissolved Solids (TDS)	mg/l		3,500	3,500
Ammonia	mg/l	10 (as nitrogen)	40	10
Oil and grease	mg/l	10	10	10
Chloride	mg/l		1,000	1,000
Total toxic metals	mg/l		2.0	2.0
Cadmium	mg/l		0.1	0.1
Chromium total	mg/l	0.5	1.0	0.5
Copper	mg/l	0.5	1.0	0.5
Lead	mg/l		0.5	0.5
Mercury	mg/l		0.01	0.01
Selenium	mg/l		0.5	0.5
Sliver	mg/l		1.0	1.0
Nickel	mg/l		1.0	1.0
Iron	mg/l	1.0	8.0	1.0
Zinc	mg/l	1.0	5.0	1.0
Urea	mg/l	1.0	no standard	1.0
Total residual chlorine	mg/l	0.2	0.1	0.1
Temperature increase	°C	< 3 at edge of zone	=< 3 at edge of zone	< 3 at edge of zone

**Note:** List includes only relevant NEQS parameter

## 3. Project Description

---

ECPL is planning on expanding its current fertilizer manufacturing facility at Daharki, Sindh by installing an additional ammonia-urea complex and associated facilities. The expansion will increase the annual production capacity of the facility from 975,000 tons by 1,267,000 tons to reach an annual production of 2,242,000 tons.

### 3.1 Project Background

The discovery of Mari Gas Field in 1957 led to the proposal to establish a fertilizer plant based on the gas from the field which was appropriate for this purpose. The construction of the plant with an annual capacity to produce 173 KT of urea was completed in 1968 by Esso Pakistan Fertilizer Company Limited, a subsidiary of Esso, a multinational industrial firm. The name changed to Exxon Chemical Pakistan Limited in 1978 following the international name change of Esso. In 1990 the plant capacity was increase to 268KT by *debottlenecking*. After the disinvestment of shares by Exxon in 1991, the company was acquired by its employees and the present name was adopted. In 1993, the capacity of the plant was more than doubled to 600 KT. It was further increased to 750 KT in 1995, to 975 KT in 1999.

### 3.2 New Development

ECPL intends to set up an additional urea and ammonia plant at its fertilizer manufacturing facility in Daharki. The new development will include the addition of 2,194 metric tons per day (MTD) ammonia plant, a 3,835 MTD urea plant, new offsite facilities, incremental utilities & residential facilities. ECPL envisions adding 1,267 kilotons (KT) per year of production to its existing 975 KT per year production of fertilizer.

In addition to the plants, the incremental utilities and offsite facilities which include water intake and storage facilities, addition in water treatment and cooling facilities, gas turbine with heat recovery steam generator, air compressor, nitrogen generator, and a new gas supply pipeline from Qadirpur to Daharki delivering 100 MMscfd of natural gas will also be developed. The exiting housing colony will also be expanded to accommodate the increased staff strength.

### 3.3 Project Location

The new fertilizer plant will be installed with in existing boundaries of the existing ECPL facility in Daharki and adjacent to the existing fertilizer manufacturing plant. However, 60 acres land would be acquired for expansion in residential facilities and 6 acres for new water intake off site facility The ECPL complex is located about 300 m south of the national highway. Major industrial units in the vicinity of the existing plant are the Liberty Power Plant and the Fauji Fertilizer Company (FFC) plant located 3 km and

13 km west of the ECPL plant respectively. The ECPL housing colony and Mari Gas Company Limited housing colony are located adjacent to the ECPL plant. The project site and its vicinity are shown in **Exhibit 1.2**.

### 3.4 Existing Plant Facilities and Operations

The fertilizer manufacturing process consists of two stages: Ammonia production and subsequently urea production. ECPL currently have one operational ammonia plant and two urea plants.

The ammonia plant being used was initially designed to produce 1,060 metric tons (MT) of liquid anhydrous ammonia per operating day from natural gas, steam and air but its production capacity was enhanced to 1,650 MT through major equipment modifications. The sequence of steps involved in ammonia production is as follows:

- ▶ Feed gas compression through Natural Gas Booster Compressor.
- ▶ Feed Gas Desulfurization
- ▶ Pre-Reformer
- ▶ Primary Reforming
- ▶ Secondary Reforming
- ▶ Carbon Monoxide shift conversion
- ▶ Carbon Dioxide removal
- ▶ Methanation
- ▶ Removal of residual carbon dioxide (CO<sub>2</sub>) and water
- ▶ Synthesis gas compression
- ▶ Catalytic conversion of synthesis gas to ammonia
- ▶ Condensation of ammonia

The raw materials used for urea manufacturing are carbon dioxide gas and liquid ammonia. Gaseous CO<sub>2</sub> from the ammonia plant is compressed to the reactor pressure of 3200-3400 pound-force per square inch gauge (psig) and fed to the urea reactor. Liquid ammonia from the Ammonia plant is received in a reservoir and after pressurizing through feed pumps, it is fed to the reactor at 3100-3300 psig. Urea is produced in the reactor at 378 ~ 380 °F and 3000 ~ 3200 psig pressure. Free or excess ammonia from high pressure circuit is condensed in ammonia condensers and recycled to the reactor with make up ammonia. In first step of the urea purification or finishing section, the urea solution is boiled under vacuum in the concentrator and water is removed at low temperatures. The remaining water is then separated with the help of hot air and evaporated. The urea is then prilled (cooled down from its molten state and converted into small beads) with the help of two prill towers and then packaged and shipped.

A couple of processes running parallel to the above include wastewater stripping in which the wastewater is removed of impurities after undergoing a process and demineralised water which is obtained through a process to make it reach a certain level

of purity. The layout of the existing plant is shown in **Exhibit 3.1**. There are two types of building structures in the existing plant. The ammonia and urea production structures, storage tanks, and product silos are steel structures whereas warehouses, generator houses, offices areas, and compressor buildings are enclosed concrete blocks.

### **3.4.1 Existing Gas Pipelines**

The natural gas for ECPL is obtained from Mari Gas through two lines:

- ▶ Line 1: This line contains only fuel gas (used for burning purposes) and is a 10 inch line with a flow of 52 MMscfd at 590 psig and 90 °F.
- ▶ Line 2: This line contains only feed gas (used for Ammonia Production) and is a 12 inch line with a flow of around 53 MMscfd at 550 psig and 80 °F.

### **3.4.2 Operational Controls**

Majority of the operations are centrally controlled and connected to computers and alarm systems in the control room. Manual operating procedures are also available for dealing with emergencies.

### **3.4.3 Power Supply**

Electrical power is supplied by in-house power generation. The in-house power generation utility of ECPL consists of three gas turbines of capacities 11.5 mega watts (MW), 13.8 MW, and 13.8 MW respectively. During normal operations two of the three available gas turbines are operated while the third is kept on stand-by. All three turbines are equipped with state of the art speed and excitation control systems. All three turbines produce power with 6.6 kilo volt (KV) potential at 50 hertz (Hz) frequency.

### **3.4.4 Existing Off-site Facility**

ECPL has a canal and groundwater intake facility at an offsite location, approximately 2.5 km west of the ECPL facility at the intersection of the national highway and the Dahar Wah canal. The ECPL offsite facility consists of water pumps, water storage tanks, flocculation tanks, clarifier, and groundwater wells. Groundwater is only used by the plant during canal closure periods.

Water from the canal is extracted with the help of canal water pumps and stored in a tank. Alum is dosed and mixed with the canal water and is then passed through flocculation tanks. Polyelectrolyte is dosed for rapid settling of suspended particles. This water is then clarified and the solid particles in the canal water settle and produce sludge. Clarified water is then pumped to plant site at a flow of 2,000 US Gallon per Minute (gpm).

## **3.5 Proposed Development Project**

Expansion of the existing Ammonia and urea manufacturing plants include the installation of following new units and facilities:

- ▶ Proposed Ammonia plant
- ▶ Proposed Urea plant
- ▶ Additional Gas pipeline from Qadirpur
- ▶ Additional utilities unit
- ▶ Off-site water facility
- ▶ Expansion of existing ECPL residential colony
- ▶ Effluent treatment plant

A brief description of each unit and additional facilities are given later in this section.

### **3.5.1 Proposed Ammonia Plant**

#### ***Design***

The proposed ammonia plant will be one of the largest in the world and is based on Holder Topsoe design. The rated daily capacity of the plant is 2,194 tons. Most of the drivers are steam turbines so electrical power requirement of the unit will be much lesser as compared with others of its kind. The plant will include following facilities:

- ▶ Desulfurization Unit
- ▶ Primary Reformer
- ▶ CO Conversion Unit
- ▶ Ammonia Synthesis Unit
- ▶ Refrigeration

A brief description of each of the different unit operations involved in the ammonia production process is as follows:

#### ***Desulfurization***

The natural gas feed stock contains minor quantities of sulfur compounds which have to be removed to avoid poisoning of the reforming and the low temperature shift catalysts. The Natural gas from battery limit is mixed with the recycle gas and heated to 365 °C in the reformer flue gas section. After hydrogenation, the hydrogen sulfide (H<sub>2</sub>S) is adsorbed on a specially prepared zinc oxide catalyst in the sulphur absorber. The sulfur contained in the natural gas shall be reduced to a very low level of 0.1 ppm by weight.

#### ***Reforming***

The reforming of the hydrocarbon feed takes place in two stages, a direct fired primary reformer and an auto-thermal secondary reformer. The hydrocarbon feed coming from the desulfurization unit is mixed with steam. The steam to carbon ratio is 3.0. The reaction mixture is preheated and taken into primary reformer where it is decomposed into hydrogen, carbon mono oxide and carbon dioxide over a nickel catalyst by applying heat. In the secondary reformer, preheated air is supplied and the heat thus generated by

burning of the gas decomposes methane. Methane concentration in the outlet gas from the secondary reformer is 0.4 vol % (dry basis).

### **Carbon Monoxide (CO) Conversion**

The CO conversion takes place in two adiabatic stages: The high temperature CO converter contains copper promoted high temperature shift catalyst, which features high activity and high mechanical strength. The low temperature CO converter is loaded with low temperature shift catalyst which is characterized by high activity, high strength and high tolerance towards sulphur poisoning. A top layer of special catalyst is installed to catch any chlorine in the gas. After reforming, about 13.5% CO is present in the gas (dry basis). In the high temperature shift converter, the CO content is reduced to 3.2% and temperature is increased to 433 °C. The gas is then cooled to 205 °C in a high pressure waste heat boiler, a trim heater and a BFW pre heater. The CO content at low temperature shift converter outlet is 0.3% (dry basis) while the temperature is increased to 227 °C. The heat contents are recovered in a BFW pre heater.

### **CO<sub>2</sub> Removal**

The gas leaving the CO conversion sections contain a considerable amount of heat, owing to the content of steam, this heat is mainly present as latent heat. This heat is recovered in the stripper re-boiler and in the pre-heater. For CO<sub>2</sub> removal activated MDEA process is used. Main equipments in a MDEA process are CO<sub>2</sub> absorber and CO<sub>2</sub> stripping column. The extracted CO<sub>2</sub> will be delivered at 40 °C and a pressure of 0.5 kg/cm<sup>2</sup>g. The CO<sub>2</sub> is removed from the process gas in two stage absorption. In the lower part of the absorber, the flashed re-generated solution is used for bulk CO<sub>2</sub> removal. In the upper part of the absorber, the strip-regenerated solution is used for scrubbing. The lean solvent from the bottom of the stripper is pumped to the top of the absorber. In this way nearly 0.05% CO<sub>2</sub> is left in the gas (dry basis).

### **Methanation**

After the CO<sub>2</sub> removal gas contains about 0.05% CO<sub>2</sub> and 0.4% CO (dry basis). These compounds are poisonous to ammonia catalyst and must be removed before the gas enters synthesis section. This is achieved in the Methanator where CO and CO<sub>2</sub> react with hydrogen (H<sub>2</sub>) to form methane. The reaction takes place over a nickel based catalyst. The CO and CO<sub>2</sub> contents are reduced to about 5 ppm. The inlet temperature to the reactor is 300 °C while outlet is 324 °C. The outlet gas is finally cooled to 40 °C with a cooling water exchanger.

### **Ammonia Synthesis**

The synthesis gas is compressed from 31 to 188 kg/cm<sup>2</sup>g in the centrifugal type two-casing synthesis gas compressor. The make-up gas from the compressor is introduced into the synthesis loop in between the two ammonia chillers. At this point a considerable part of the ammonia produced in the converter has been condensed. The mixture of liquid ammonia and synthesis gas passes from the second chiller to the ammonia separator in which the liquid ammonia is separated and the outlet gas contains about 4.0% vol ammonia at 0 °C.

Then ammonia is condensed and traces of impurities in make-up gas like water and CO<sub>2</sub> are absorbed in liquid ammonia phase and removed with the liquid ammonia in the separator. The make-up gases contain small amount of the inert gases like Methane and Argon. In order to prevent these gases from accumulating in the loop, a certain quantity of the circulating gas is purged and sent to the purge gas chiller and the liquid ammonia thus formed is separated in the purge gas separator and returned to the bottom of ammonia separator. The remaining ammonia in the purge gas is removed by water wash in the purge gas absorber. Under base case conditions the washed gas is mixed with off gas from off gas absorber and sent to reforming section as fuel.

The recovered H<sub>2</sub> rich gas is recycled back to the loop and the off gas used as fuel in the reforming section. In both cases aqueous ammonia is distilled in distillation column, together with aqueous ammonia from off gas absorber and the recovered ammonia is added to the ammonia product in let down vessel.

### **Refrigeration circuit**

The refrigeration circuit consists of a compressor unit, a condenser, an accumulator and a number of chillers. The unit is designed to operate in two modes, depending on whether ammonia is sent to storage as cold product or to downstream urea plant as hot product. The ammonia is chilled in a two-stage process and compressed after which it is condensed in the ammonia condenser.

### **Ammonia recovery**

Purge gas from the purge gas separator is sent to the purge gas absorber. Ammonia is washed out of the gas with water. The inert gas and let down gas is introduced to the off gas absorber and ammonia is washed out with water. The aqueous ammonia is sent to the distillation column where the ammonia is distilled off and returned to the let down vessel. The off gases are mixed and sent to the fuel header.

### **Steam system**

The major part of the waste heat available is utilized for production of high pressure steam where 120 kg/cm<sup>2</sup>g is produced in waste heat boilers. The HP steam is superheated in the steam super heater in the flue gas duct. The HP steam raised in ammonia plant covers the demands on internal system at normal operating conditions. This includes steam for the main turbines as well as process steam for the reforming process.

### **New Ammonia Storage Tank :**

A new Ammonia storage tank of 5,000 MT capacity shall be installed. This liquid Ammonia storage tank shall be double-wall double integrity type, external insulation, designed and constructed so that both primary and secondary self supporting containment shells will be capable of independently containing refrigerate liquid. Ammonia will be stored in the tank at atmospheric pressure. The outer tank will be designed to safely contain liquid ammonia in case of leakage of the inner tank. Flares shall be installed on new Ammonia Storage System for burning any Ammonia Vapors which may release from safety valves and vents installed on the storage tank. Existing single walled tank on the site will be decommissioned.

### **Alarm and Interlock system**

In order to avoid incidents like over pressurization, release, fires or run away reaction, necessary alarms and interlock systems will be installed. Flammable gas detectors will be installed in the areas where flammable gases exist. Alarms will sound in the Emergency panels in the control room.

### **Waste Gas**

The waste gas emission in the ammonia plant can be categorized into continuous and intermittent emissions. The continuous emissions include the primary reformer flue gas. Carbon monoxide, SO<sub>x</sub>, and NO<sub>x</sub> content in this gas will be well below the NEQS and World Bank standards. These will be released into the atmosphere. Intermittent emissions resulting from process upsets will be flared at the front end and back end flares.

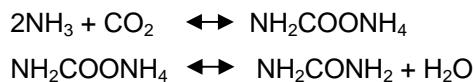
### **Noise**

The main sources of noise in the proposed ammonia plant include blowers, compressors, and pumps. The majority of equipment to be used can produce a noise of less than 95 dB(A) except a few close to 100 dB(A).

### **3.5.2 Proposed Urea Plant**

Urea is produced by synthesis from liquid ammonia and gaseous carbon dioxide.

In the Urea Reactor, the ammonia and carbon dioxide react to form ammonium carbamate, a portion of which dehydrates to urea and water. The reactions are as follows:



The liquid ammonia feed to the Urea Unit, coming from the relevant Ammonia Unit, is filtered through NH<sub>3</sub> Filters and is collected in the Ammonia Receiver Tank. The liquid mixture of NH<sub>3</sub> and carbamate enters the urea reactor bottom where it reacts with the carbon dioxide compressed feed.

### **Urea Purification & Prilling**

Urea purification and relevant overhead gases recovery take place in two stages at decreasing pressure, as follows:

- ▶ 1st stage at 18.8 kg/cm<sup>2</sup> abs. pressure
- ▶ 2nd stage at 4.8 kg/cm<sup>2</sup> abs. pressure

Furthermore, the exchangers where the urea purification takes place are called decomposers as in these equipments the residual carbamate decomposition take place.

### **Urea Prilling**

The melted urea leaving the Vacuum Separator Holder is sent to the Prilling Bucket by means of a centrifugal pump. Droplets of molten urea from the prilling bucket fall along the natural draught Prilling Tower and solidify and cool while encountering a

countercurrent air flow. Solid prills are collected at the centre of Prilling Tower bottom by means of the conical double arm Rotary Scraper and through a conical hopper, they fall onto Prilling Tower Belt Conveyor. The screen, located downstream, removes any urea lumps or agglomerates which are discharged directly and dissolved in the underground Urea Close Drain Tank through the Urea Recycle Belt Conveyor.

### **Alarm and Interlock system**

In order to avoid incidents like over pressurization, release, fires or run away reaction, necessary alarms and interlock systems will be installed. Flammable gas detectors will be installed in the areas where flammable gases exist. Alarms will sound in the Emergency panels in the control room

### **Waste Gas**

The waste gas emission in this urea plant would be sent to continuous and discontinuous flares which will be employed to burn-off the gases. The total flow to the continuous flare would be 1,378 Nm<sup>3</sup>/hr with 1.7% ammonia. This gas will be flared as compared with direct venting, in earlier technologies.

### **Noise**

The main sources of noise in the proposed Urea plant include blowers, compressors, and pumps. The majority of equipment to be used can produce a noise of less than 90 dB(A) except a few close to 95 dB(A).

### **Operational Waste**

#### *Total Liquid Effluents Produced (Ammonia and Urea Processes)*

The total amount of liquid effluent produced from both the proposed ammonia and urea processes is approximately 136 m<sup>3</sup>/hr. This liquid effluent consists of 125 m<sup>3</sup>/hr resulting from cooling tower blow down and the rest consisting of oily effluent, utilities chemical drain, chemical sewer, oil dripping sewer, and domestic sewer. Cooling tower blow down is non-hazardous and can be used for horticulture or other irrigational purposes. Detailed information is provided in the **Exhibit 3.2**.

#### *Total Solid Waste Produced (Ammonia and Urea Processes)*

The total amount of solid waste produced from both the proposed ammonia and urea processes is 7,127 tons/year. This solid waste consists of 3 tons/year of activated carbon, 7,000 tons/year of canal water sludge, 70 tons/year of cooling water basin sludge and 54 tons/year of catalyst. Bulk portion of the solid waste is in the form of canal water sludge which is a mixture of clay and water produced after purification of canal water. This sludge is non-hazardous and it will be dried and used as land fill. Detailed information is provided in the **Exhibit 3.3**.

### **Effluent Treatment Plant for Colony**

A new 100 m<sup>3</sup>/hr effluent treatment plant to treat domestic sewage from the housing colony shall be installed. The plant will use most modern technology to treat the sewage

to comply with NEQS and World Bank Standards. After disinfection the treated water will be used for horticulture and irrigational purposes. Plant will also produce organic fertilizer which will be utilized in maintenance of greenery in housing colonies & plant site.

### **3.5.3 Natural Gas Pipeline**

The total natural gas requirement for the expansion site is 97.88 MMscfd which will be met by laying down a new natural gas line from Qadirpur gas field to ECPL site. This line will be 35 km in length and 20 inches in diameter. It will be equipped with adequate safety devices (multiple pressure safety valves, cathodic protections, etc). The line will be owned and operated by SNGPL.

#### **Utilities Overview and Operating Program**

Following utility systems will be kept centralized and used at both the existing and proposed plants:

- ▶ Reverse Osmosis System
- ▶ Treated water System
- ▶ Power distribution system
- ▶ Fire water system

Following systems of new plant will be completely independent:

- ▶ Instrument / plant air system
- ▶ Raw water system
- ▶ Effluent treatment system
- ▶ Power & Steam generation
- ▶ Polished water system
- ▶ Nitrogen system
- ▶ Cooling water system

Some of the new plant utilities being set up are described in the following sections. Power will be supplied to the proposed facility using a 20 MW in-house gas turbine. This will be added to the existing gas turbines at the ECPL facility.

#### **Canal Water System**

The canal water requirement for expansion site will be 1,140 m<sup>3</sup>/hr. New off-site facility will supply raw water to expansion requirement. This facility will be built close to existing off-site. Raw water coming from the canal will be clarified in primary clarifier. Alum and poly electrolyte solution will be dosed to aid settling of suspended solids. The sludge coming from the bottom of primary clarifier is thickened in sludge thickener. Slurry coming from the bottom of sludge thickener will be sent to drying beds. The filtered water from the drying beds will be recycled back to clarifier. Dried sludge will be disposed off in desert. Land will be procured for disposal of dried sludge from drying

beds. During canal water operation, high lift pumps will transfer water from off-site to ECPL plant.

### **Clarification Facility**

Clarification facility will be designed on the following basis.

- ▶ Water flow rate 1,935 m<sup>3</sup>/hr
- ▶ Suspended Solids (SS) in inlet water 600 ppm
- ▶ Total Dissolved Solids (TDS) in inlet water 250 ppm
- ▶ SO<sub>4</sub> in inlet water 60 ppm
- ▶ SS in outlet water Less than 10 ppm

For removal of SS from the clarification facility Sludge drying beds of appropriate design shall be provided.

### **Potable Water System**

Potable water will be used as drinking water at site. Normal expansion requirement for potable water will be 110 m<sup>3</sup>/hr. Six new wells will be constructed at off-site to meet this requirement. New line will be laid from off-site to a storage tank for potable water supply. New potable water pumps will be installed at the plant utility section. Existing colony network will be expanded for drinking water supply to new houses.

### **Reverse Osmosis (RO) Unit and Demineralization**

RO system will be setup to treat canal/well water coming from off sites. RO permeate will be fed to demineralization unit. Demineralized water will be generated from existing demineralization unit located at the existing plant site. New demineralization train similar to existing trains will be installed to meet expansion requirement.

### **Polished Water System**

Demineralized water generated at the utility section will be supplied to an intermediate tank. Process condensate and steam condensate coming from the new ammonia and urea plants will also enter in this tank. The water from intermediate tank will be passed through mixed bed, polished, and then stored in a polished water tank.

### **Offsite Water Intake Facility**

The existing offsite water intake facility located at the Dahar Wah and national highway intersection about 2 km west of the ECPL plant will also be expanded as part of the proposed expansion project.

Several new groundwater wells will be drilled in the vicinity of the existing wells adjacent to the canal. The development of the offsite facility will also include the addition of water pumping capacity at the existing offsite facility.

### 3.5.4 Employment

The priority in employment will be given to the communities in the surroundings of the project area for all unskilled jobs as is the case in the current scenario where 80% of unskilled labor is from the surrounding areas. During the construction phase, the following manpower will be hired by the construction contractor:

Management or indirect manning :	334
Skilled/supervisors/unskilled :	2,000

Once the construction is completed and the plant comes into the normal operation phase, 39 management employees and 256 non-management employees will be added to ECPL's existing manpower. Furthermore, services contracts would be given for certain type of jobs which will create 300 contract jobs.

#### ***Expansion in the Existing ECPL Residential Colony***

In order to cater for the increased workforce due to the proposed project the existing ECPL residential colony will also be expanded. This will include acquisition of 60 acres of land. It is expected that of the additional 39 management staff, 65% would move into the colony with their families requiring family accommodation while the rest would require bachelor accommodation. Of the 256 non-management staff it is expected that 80% would require family accommodation. In addition to this the colony will also house the staff of the Engro Energy Limited.

In total accommodation for the management staff would house about 175 persons whereas the accommodation for non-management staff would house over 800 persons. Additional land will be acquired for the expansion of the colony.

### 3.6 Expansion Project Construction Activities

The construction of the proposed plant and the residential facilities will be undertaken by preparation of the site followed by installation of the equipment. These steps are described below.

#### ***Site Preparation***

ECPL has existing land 350 acres. No new area for the proposed plant expansion was acquired. Construction of the plant will include groundwork, followed by installations and concrete works.

Once the site sub-base has been prepared, the underground infrastructure will be installed and foundations laid for the process equipment and supporting infrastructure. The sealed site roads and paved areas will also be constructed.

Typical activities that are conducted during the civil construction are:

- ▶ Excavation for foundations
- ▶ Laying of foundations
- ▶ Masonry work
- ▶ Concrete work

- ▶ Asphalt work (pavement, roads, etc.)
- ▶ Finishing (plastering, painting, etc.)

### **3.6.1 Plant Installation**

The new units of each plant and ancillary equipment, brought to the site by road in sections, will be erected on site and hooked-up.

#### ***Pipeline Laying***

The pipeline construction will include following activities:

- ▶ RoW preparation and grading
- ▶ Stringing
- ▶ Field bending
- ▶ Lineup welding
- ▶ NDT weld testing and repairing
- ▶ Weld joint coating and coating repair
- ▶ Trenching
- ▶ Lowering-in
- ▶ Backfilling
- ▶ Tie-ins
- ▶ Block valve installation and electric and installation works
- ▶ Cathodic protection installation
- ▶ Flushing, hydrostatic testing, and dewatering
- ▶ RoW restoration
- ▶ Line marker installation

Additional activities involved in the laying down of the gas pipeline are described below.

#### ***Site Preparation***

Top soil will be removed and stored separately on the RoW to allow for appropriate rehabilitation at the completion of construction phase. Prior to placing the fill over existing terrain, all loose soil and all vegetation, roots, and other organic material will be dug up to a suitable depth.

#### ***Natural Gas Pipeline Laying***

The natural gas pipeline will be laid below ground along its entire route with the exception of some minor instances for instance at a canal crossing where the pipeline will have to cross over land.

#### ***Pipeline Cleaning and Testing***

After a section of the pipeline has been installed, a traceable brushing pig will be sent down the section of a line for cleaning as well as removing some of the debris and water that is likely to be accumulated in the pipeline during construction. The waste (predominantly water with some soil residue) will be removed from the pipe. Flushing with clean water will then further clean the line. A pig train containing water (comprising a pig, water, pig sandwich) will be sent down the line. The test water will be disposed of using one or more of the means listed below. A suitable option will be selected on the basis of quantity of water, pollutant concentration (if any), and technical feasibility.

### **Restoration and Rehabilitation**

Restoration will be undertaken after the pipeline has been laid. It will include compacting the backfilled material; placing the topsoil stockpiled during the trenching phase as the topmost soil layer; re-contouring the RoW to its original conditions to the extent possible; repairing any natural drainage paths if required; removing any surplus soil, leftover materials, and debris from the site for appropriate disposal; and implementing any re-vegetation and soil erosion protection measures required. Special attention will be given to local irrigation watercourse crossings.

### **3.6.2 Construction Camps**

Separate construction camps will be set up for the construction of the plant and the gas pipeline. The construction camp for the plant's construction is as per **Exhibit 3.1**. The main campsite will include the following facilities:

- ▶ Aggregate Storage Yard + Batch Plants
- ▶ Cement Storage Yard
- ▶ Descon Storage Yard
- ▶ Rebar Fabrication Yard
- ▶ Rebar Laydown Yard
- ▶ Shuttering Plates Yard
- ▶ E&P Yard
- ▶ Carpentry Yard
- ▶ Descon Office
- ▶ Pre-Cast Laydown Yards
- ▶ Descon Camp
- ▶ Time Office
- ▶ Raw Material Storage Yard
- ▶ Fabrication Lay out Shop
- ▶ Machine Shops
- ▶ Fabrication Shop

- ▶ Test & Inspection/Trial Assembly
- ▶ Sand Blasting Yard
- ▶ Painted & Finish Parts Storage Yard
- ▶ Ware House Mechanical and E&I

A separate liquid sewage disposal will be established for the construction campsite. Power will be supplied to the site via diesel generators. All contractor solid waste materials will be treated.

After the completion of construction, the construction campsite will be rehabilitated.

### **3.6.3 Equipment**

The equipment typically used during construction and while laying the pipeline is:

- ▶ Survey sets
- ▶ Dozers, loaders, dump trucks, cranes, and trailers
- ▶ Concrete mixers and asphalt plants
- ▶ Pipe-bending machines, cutting outfits, beveling machines, grinders, welding units, radiography equipment, sand-blasting units, coating units, and painting equipment
- ▶ Excavators, thrust-bore equipment, ditch pumps
- ▶ Pipe-layers, tractors, fuel trucks, service trucks, water tankers with sprinklers, and crew vehicles
- ▶ A water-treatment plant, strainers, fill-up pumps, hydrostatic testing equipment, temperature and pressure recorders, and air compressors
- ▶ Generators
- ▶ Communication equipment
- ▶ Mobile maintenance units
- ▶ Warehouse storage units.

### **3.6.4 Construction Material Sourcing**

During the construction, material such as the steel, cement, sand, and aggregates for road and pavement construction will be required.

### **3.6.5 Waste Streams**

The primary source of emissions to air for construction activities will be diesel engine-driven-generator exhaust. Other emission sources include construction machinery and vehicle exhaust emissions. Dust from the construction activities and movement of vehicles will be the other main source of air emissions.

The sewage will be treated in a closed system and the effluent will then be taken to the municipal facility. Alternatively, the gray water will be sprinkled on unpaved sections within the construction corridor.

Recycling or reuse of waste material is the preferred option. However, where that is not possible, waste will be treated and appropriately disposed of as per ECPL's policy and other contractual obligations.

**Exhibit 3.4** lists the types of wastes that are expected to be produced during the construction phase and their planned disposal options.

### **3.6.6 Site Restoration**

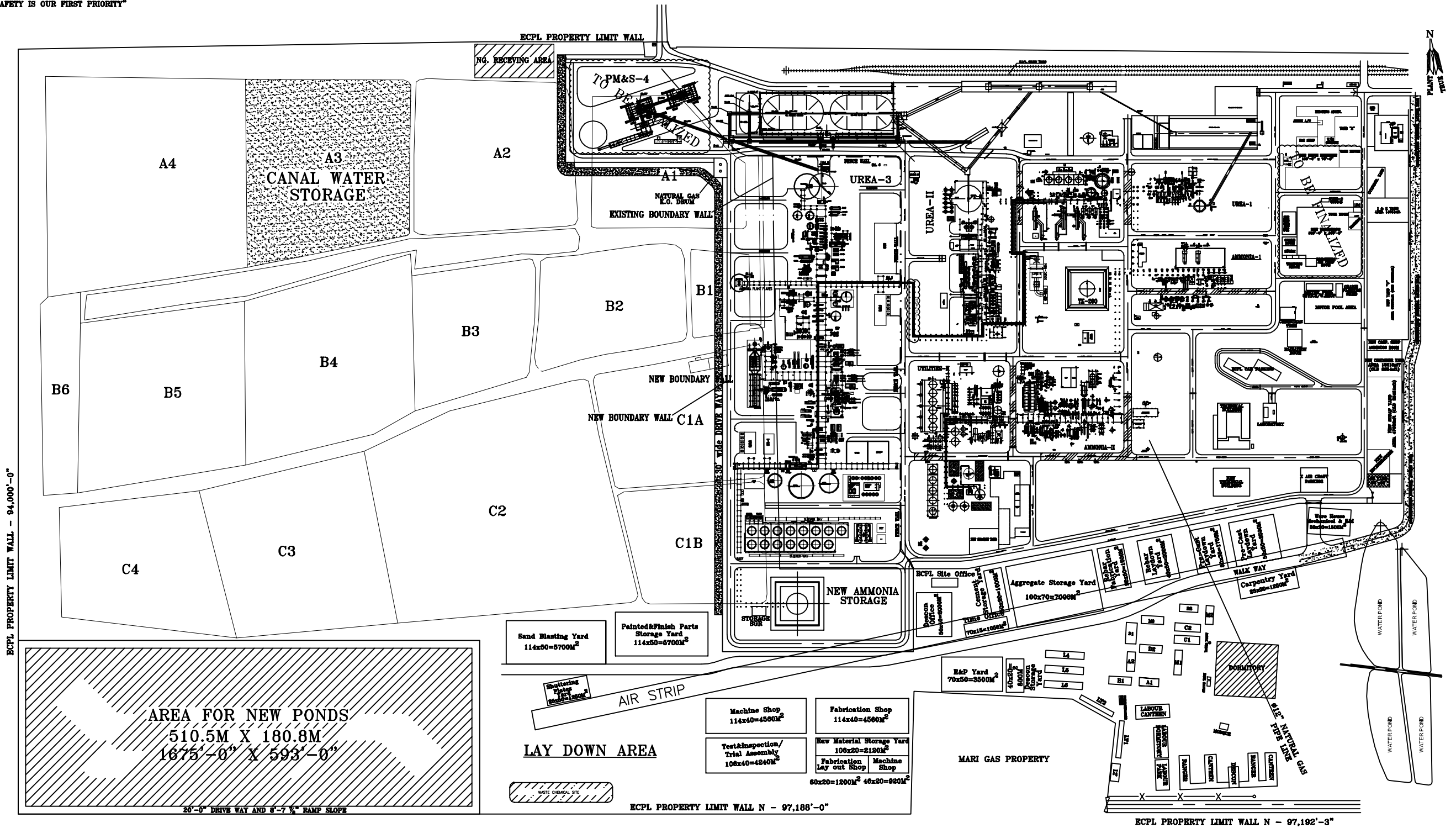
On completion of the construction phase, the temporary infrastructure will be decommissioned and sites restored. This will involve:

- ▶ Removing the temporary construction camp
- ▶ Reinstating the pipeline route back to the original condition
- ▶ Closing all the temporary waste pits
- ▶ Leveling and restoration of borrow areas.

Site restoration also involves reinstatement of vegetation and topography.

### **3.6.7 Construction Schedule**

The total construction period from the award of contract to the construction contractor till the completion is expected to be 40 months. The project construction is expected to commence in the second half of 2007.



**EIA of ECPL Expansion Project**

**Exhibit 3.1  
ECPL Plant Layout**

Scale	1 : 4750
Source	ECPL
Drawing	W7E04DEE
Date	May 2007
Client	Engro Chemicals Pakistan Limited

**Exhibit 3.2: Total Liquid Effluents Produced**

<i>Description</i>	<i>24-hour Average Flow (m<sup>3</sup>/hr)</i>	<i>Maximum Flow (m<sup>3</sup>/hr)</i>
Cooling Tower Blowdown	125.0	230.0
Oily Effluent <sup>1</sup>	0.00115	0.003
Utilities Chemical Drain	5.0	50.0
Chemical Sewer	3.0	90.0
Oil Dripping Sewer	0.001	0.01
Domestic Sewer	3.0	17.0
Rainwater	–	2,060.0

**Exhibit 3.3: Total Solid Waste Produced**

<i>Category</i>	<i>Tons/year</i>	<i>Kg/Ton of Urea Produced</i>
Activated Carbon	3.0	0.0007
Canal Water Sludge	7000	1.82
Cooling Tower Basin Sludge	70.0	0.018
Catalyst <sup>1</sup>	54.0	0.014
<b>Total</b>	<b>7127</b>	<b>1.85</b>

<sup>1</sup>: Averaged on 10 years cycle.

Non-NEQs compliant effluent will be handled as mentioned in operating philosophy of ECPL

**Exhibit 3.4: Construction Wastes**

<i>Category</i>		<i>Waste Generated</i>	<i>Disposal</i>
<b>Liquid Waste</b>			
Hazardous		Waste oils, lubricants	Stored and transported to offsite (eg, Karachi) for authorized disposal/recycle facility.
		Sewerage	Wastewater treatment plant
Non-hazardous		Test water from pipeline that meets NEQS	Evaporation pond, surface water, or irrigation
<b>Solid Waste</b>			
Hazardous		Paint tins, batteries, rubber tires, used oil filters, chemical containers (crushed), other hazardous waste, contaminated soil (chemical), sewage sludge, grease trap sludge	Hold at on-site hazardous waste storage facility until an off-site hazardous waste disposal facility is developed and approved
		Hydrocarbon contaminated soil	Incineration
		Product and chemical containers (including partially full)	Return to vendor
Non-hazardous	Recyclable	Cable drums, wood, packaging, buildings materials, plastic sheeting, cement bags, scrap metal, recyclable plastic sheeting	Recycling (via approved vendors)
	Non-recyclable	Incinerable	Food waste, papers, non-recyclable wood/packaging
		Non-Incinerable	Concrete waste, incineration ash, polystyrene

## 4. Description of Environment

---

This section describes the environment of the project area (**Exhibit 1.2**). The project area is defined as the areas where the project related activities to be carried which include the proposed project site and surroundings and the areas that can interact with the project's positive and negative externalities in the long run. The description provided in this section is based on published information and field survey data that was collected specifically for this study. The field surveys were conducted in March and April of 2007.

The purpose of reviewing published literature was to gather information on the environmental setting and the work already carried out in the area. The relevant literature was of the previous studies conducted in the project area or in areas with a similar geographical and ecological setting. A complete list of references is provided at the end of this report.

Field studies carried out between March and April 2007 entailed surveys included public consultation, noise survey, and measuring the ambient air quality of the project area. Appropriate standard scientific methods have been used for each component of the study, and are described in the sections covering the respective components. A Global Positioning System (GPS) was used to mark the vegetation, wildlife, and socioeconomic study sites.

### 4.1 Natural Environment

#### 4.1.1 Topography, Geology, and Soils

The project area is located in the sedimentary Southern Indus Basin south of the Sukkur Rift—the divide between the Central and Southern Indus Basins. The Southern Indus Basin consists of the Thar Slope Platform, the Karachi Trough, the Kirthar Foredeep, the Kirthar Fold Belt, and the Offshore Indus. The platform and trough extend into the Offshore Indus. The Thar Platform is a gently sloping monocline, whereas the sedimentary wedge thins towards the Indian Shield to the east. The platform, bordered on the east by the Indian Shield, merges into the Kirthar and Karachi Trough in the west and is bordered in the north by the Mari-Bugti Inner Folded Zone (Kadri, 1994). Reserves of natural gas are found in the Lower Kirthar ZN-‘B’ Limestone Formation.

The project location is surrounded by cultivated land. Soil types range from dark brown sandy loam in most places to light-brown sand in others. The area's soils contain adequate moisture and nutrients for agricultural use. The soils are porous and slightly alkaline (pH 7.5) in nature and contain appreciable quantities of organic matter (0.65 %). The area's land mass is generally flat, with parcels of some minor undulations in some places.

#### 4.1.2 Seismicity of the Project Area

According to one classification Pakistan has 15 seismo-tectonic regions.<sup>1</sup> The Geological Survey of Pakistan has classified the project area as seismic zone A2 which according to the Munich Re 'World Map of Hazards' is Zone 2, corresponding to Intensity VII of the Modified Mercalli Scale of 1931.<sup>2</sup> The local effect of Scale VII earthquake is described as: 'Everybody runs outdoors. Damage negligible in buildings of good design and construction, slight to moderate in ordinary structures, and considerable in poorly built or badly designed structures. Chimneys broken. Felt in moving automobiles.'<sup>3</sup> Scale VII corresponds to average peak ground acceleration of 0.10–0.15 g (acceleration due to gravity, which is equal to 9.80 meter per second square), and an average peak velocity of 8–10 centimeter per second. The peak ground acceleration values in the Zone 2 according to the Building Code of Pakistan ranges from 0.08 to 0.16 g. To design for seismic conditions, ECPL uses information that was developed by Exxon Research Engineering (ERE) and designs buildings and structures as if they are located in the 'Active Seismic Region (Seismic Factor 0.1 g to 0.05 for Building)' as defined by ERE.

#### 4.1.3 Water Resources

The area surrounding the proposed project site does not contain any natural surface water bodies such as rivers, springs, etc. The Indus River is flowing in from Punjab and heading southwards into the Arabian Sea is located approximately 20 km northwest of the project area. The main surface water bodies in the surroundings of the project area are the two irrigation canals, the 'New Mahi Wah' and the 'Dahar Wah'. The New Mahi Wah is located approximately 3 km west of the ECPL facility. The existing offsite water intake facility of ECPL is located at the bank of this canal. The existing offsite water intake facility will also be expanded to meet the additional water requirements of the proposed expansion project. The Dahar Wah is located about 1 km south east of the ECPL facility.

#### Groundwater

The groundwater aquifers in the project area are described as moderately thick and extensive with a potential yield of between 100 and 150 m<sup>3</sup>/h (Survey of Pakistan, 1989). Groundwater in the area is saline and is tapped through hand pumps and wells. The water table in the project area is shallow (less than 2 m). The depth of the water table varies significantly during the year with the field irrigation regime and changes in flow in

---

<sup>1</sup> Quittmeyer, R. C. 1979. *The Seismicity of Pakistan and Its Relation to Surface Faults in Geodynamics of Pakistan*. Quetta: Geological Survey of Pakistan.

<sup>2</sup> Unlike earthquake magnitude, which indicates the energy a quake expends, the Modified Mercalli Intensity Scale of 1931 is designed to describe the effects of an earthquake, at a given place, on natural features, on installations and on human beings. It has 12 divisions, using Roman numerals from I to XII. I is the mildest—described as: 'Not felt except by a very few under especially favorable circumstances'—and XII is the most severe—'Damage total. Waves seen on ground surfaces. Lines of sight and level distorted. Objects thrown upward into the air.'

<sup>3</sup> United States Geological Survey. 1998. [http://neic.usgs.gov/neis/intensity/pym/mmi\\_abbrev.html](http://neic.usgs.gov/neis/intensity/pym/mmi_abbrev.html). Accessed March 9, 2004

the Indus River and the canals (Nazir, 1993). It has been observed that the water table has risen over time, which can be attributed to increased irrigation.

### **Water Quality**

Water samples were collected from various points in the project area by HBP during an earlier field survey (April 2006) for water quality analysis. These samples were handled as per United States Environmental Protection Agency (USEPA) sampling procedures. Total dissolved solids (TDS) contents were analyzed for all the samples at the HBP laboratory in Islamabad. These tests were conducted according to the guidelines laid down by the American Public Health Association (1985). The analysis of these samples showed that the TDS levels from eight samples collected from the project area each had the TDS levels in excess of 500 mg/l. The Pakistan Standard and Quality Control Authority (PSQCA) set the acceptable range for TDS between 100-500 mg/l.

#### **4.1.4 Climate and Air Quality**

##### **Meteorology**

The weather station closest to the project area is located at Sukkur (27° 42' N, 68° 54' E), approximately 60 km southwest of the project site. The climatic description of the project area presented in this section is based on weather data for Sukkur.

##### **Rainfall**

The project area receives approximately 88 mm of rain annually (Pakistan Meteorological Department, 1992). Most of the rain is concentrated in the monsoon months of July and August.

##### **Climatic Classification**

The climate of the project area is broadly described as hot and arid. Various meteorologists have developed classification schemes to describe the local climatic features of Pakistan. Classification based on two of the schemes is described below.

Shamshad (1956) has classified the climate of Pakistan on the basis of characteristic seasons found in the country. Taking into account topography, proximity to the sea, rainfall, temperature, and winds, he has defined eleven climatic zones for Pakistan. Under his scheme, the climate of the project area is classified as 'subtropical double season hotland.' The characteristic features of this climatic zone are low rainfall (less than 250 millimeters per annum), hence the absence of a well-defined rainy season, and high temperatures that increase from east to west. The region west of the Indus River experiences the highest temperatures, as it is cut off from the westerly summer breeze by neighboring hills.

Kazi (1952) divides Pakistan into four major climatic regions, which are further subdivided into 18 micro-regions. Under this classification, the project area falls into the central irrigated plains of the sub-tropical Indus lowlands. The region is characterized by aridity and continentality, with high summer temperatures and late summer rains. Rainfall is less than 250 mm and concentrated in June to September. July and August are

the hottest months and October and November the driest. June and January are the hottest and coldest months, respectively. The presence of irrigated fields mitigates the summer heat to some extent.

### **Seasons**

Broadly speaking, there are four seasons in Pakistan:

- ▶ Winter (December to March)
- ▶ Summer (April to June)
- ▶ Monsoon (July to August)
- ▶ Post-Monsoon Summer (September to November).

These seasons are defined on the basis of temperature and the changes associated with the southwest monsoon. The southwest monsoon is a wind system that prevails from April to October in the Indian Ocean, and is characterized by a reversal in wind direction and heavy rainfall over most of the Indian subcontinent. Within Pakistan, considerable variation is found in temperature and monsoonal changes. Thus, the specific characteristics and duration of seasons depend on geographic location. Monthly temperature, humidity, rainfall and wind data are provided in **Exhibits 4.1 to 4.3**.

#### **4.1.5 Ambient Air Quality**

The ECPL's existing fertilizer plant, the Liberty power plant, and the Fauji Fertilizer Company (FFC) fertilizer plant are the significant sources of gaseous emission in the project area. Other sources of gaseous emissions are the vehicular exhaust emissions from the highway traffic in the area.

To assess the ambient air quality for the project area, ambient air quality was recorded at two separate locations around the project site from March 8 to 9, 2007. Detailed results of the measurements are included as **Appendix B**.

## **4.2 Description of Natural Environment**

The project area falls in the tropical thorn forest ecozone, which is part of the vast Saharo-Sindian region extending from the Atlantic coast of the Sahara (North Africa), to Pakistan, and mainly consists of alluvial plains (Ali and Qaiser, 1986).

#### **4.1.6 Flora**

The area surrounding the ECPL facility is irrigated agricultural land, and does not support rare or threatened plant species. All the plant species present in the site are cultivated. *Acacia nilotica*, *Dalbergia sisso*, *Alibizia lebbek*, *Euclyptus camaldanesis* and *Zizyphus numularia* are the tree species that are planted along the margins of agricultural fields. These plants are mostly used by the local for fodder and fuel wood purposes.

Major tree species include *Acacia nilotica*, *Tamarix* sp., *Zizyphus numularia*, *Arundo donax*, *Saccharum spontenium*, *Aeva javanica*, *Tribulus* sp., and *Calatropis procera*. Mostly the domestic livestock is grazed and browsed in this area.

Exotic species like *Prosopis juliflora*, *Prosopis juliflora* and *Euclyptus camaldensis* are present in barren land along the road side and around the settlements in the project area. These exotic species are fast spreading and covering most of the bare land of the area. **Appendix C** gives more details on plant species found in the project area.

#### 4.1.7 Fauna

The proposed project site is located in a completely modified area, with no natural wildlife habitat in the vicinity. Only very common and adaptable animal species are found in the project area. No threatened and vulnerable animal, birds and reptile species are reported from the area. Asiatic jackal, Indian crested porcupine, desert fox and palm squirrel are the common large animals that are found in the project area. Other small mammals that are reported from the area are Indian desert jird, house rat, Indian jerbil and house mouse.

The project area is inhabited by number of resident and migratory birds. Common kingfisher, little brown dove, little egret, cattle egret, house crow, Indian robin common myna, white-cheeked, common babbler, house sparrow, and white wagtail are the common resident birds that are found in the project area. The migratory birds that are reported from the project area include common crane, common quail, rosy pastor, and common starling.

The reptile species that are observed or reported from the project area are ground agama, Afghan ground agama, Indian garden lizard, Indian sand-swimmer and Indian desert monitor.

The complete list of animals, birds and reptiles observed or reported from the area are shown (**Appendix C**).

### 4.3 Socioeconomic Environment

This section describes the key socioeconomic features of the study area, including the administrative setup, villages, population, education, health, infrastructure, occupations, and cultural resources. See **Exhibit 4.4** for demographic data and **Exhibits 4.5** and **4.6** showing photographs of some of the socioeconomic features of the project area. For the socioeconomic study, the project area includes area lying within 3 km radius of the proposed expansion site.

#### 4.3.1 Administrative Setup

The study area is located in Ghotki District of Sind Province. Ghotki District comprises 5 Talukas ie Daharki, Ghotki, Khangarh, Mirpur Mathelo, and Ubauro. Most of the study area is located in Daharki Taluka. A small portion in the west is in Mirpur Mathelo Taluka. The Taluka boundaries in this area are not well documented. There is a discrepancy in the Survey of Pakistan sheets, Population Census Organization reports, and the information provided by the local respondents.

The district borders Rahim Yar Khan and Jacobabad districts on the north, Sukkur district, on the south Jasalmir State of India on the east and on the west again it borders Jacobabad district. The total area of the district is 6,083 km<sup>2</sup>. The total population of the

district was 970,549 as enumerated in March 1998 with a male-female ratio (number of males for every 100 females) of 111:100 (Population Census Organization, 2000).

As per the survey for the EIA, there are 10 villages or settlements in the project area. The size of the villages ranges from 15 to 2,630 houses. The average household size in the study area is 6.1 as compared to the average household size of 5.5 in the Ghotki district (Population Census Organization, 2000).

The administrative association of each village as reported by the respondents is provided in **Exhibit 4.7**.

#### **4.3.2 Population**

Total population of the villages surveyed numbers 21,450. Demographic data for the villages is given in **Exhibit 4.4**. According to the data collected, there is currently a potential workforce of 4,290 men in the project area.

##### **Age Distribution**

Out of total population of the project area 10,940 persons above and are 10,510 below the age of 15 which constitutes an approximate ratio of 51-49 respectively. While the census results for the Ghotki district report that 46.72% of total population is below the age of 15.

##### **Male-Female Ratio**

The data collected indicates that the male-female ratio is around 111:100, ie, the males in the project area outnumber the females. While the 1998 population census report for the Ghotki district indicates the male-female ratio as 111:100. This implies that the population pattern of the project area is similar to that of the Ghotki district.

#### **4.3.3 Housing**

The field survey reveals that there are approximately 2,630 houses in the project area which can be subdivided into pakka (made of concrete) 1,578 (60%) and kacha (made of clay) 1,052 that is the 40% of total houses.

#### **4.3.4 Tribes**

Most residents of the study area speak *Sindhi* and *Siraiki*. The major tribes of the area are *Bhutto*, *Samejo*, *Soomroo*, *Shaikh*, *Buraro*, *Senghar*, *Lakhan*, *Sawand*, *Jiskan*, *Drigh*, *Khoso*, *Kolachi*, *Sangi*, *Syed*. Arain, and Arbani.

##### **Conflicts Resolution**

Conflicts mainly arise on issues of land and irrigation water. Most decisions are made by the village elders and wise men. People go to courts or consult the police usually as a last resort.

### 4.3.5 Community Livelihood

According to the findings of the survey 46% of the total employed persons are engaged in agriculture that entails direct farming and supportive activities followed by government services and elementary occupations (sales and services, fishery and related labors, mining, construction, manufacturing, and transport) constituting 40%. Remaining 14%; are either semi employed or involved in the informal economic sector **Exhibit 4.8** presents the details of the source of income.

#### **Agriculture**

Majority of the people in the project area is engaged in agriculture. Their socioeconomic condition on the whole is not very encouraging. Only a few persons own big landholdings. The rest are either landless *haris* or petty *khatedars* who live from hand to mouth. The principal crops of the district are sugarcane, wheat, cotton, rice, maize, jawar, bajra, gram, barley, tobacco etc. In the rural area of the district cultivation is mostly dependent upon canal water in the district main source of irrigation is Ghotki feeder which flows from river Indus at Guddu Barrage and radiates several small canals irrigating the agriculture lands. The other means of irrigation are tube wells and dug wells.

#### **Livestock**

The practice of livestock rearing is purely for household needs and not for commercial purposes. As such, this particular aspect of an agrarian economy is largely overlooked. Based on the survey of 10 villages and settlements, the mean livestock holdings are also sufficient to meet the domestic needs.

### 4.3.6 Drinking Water

A significant majority (80.61%) of people in the Ghotki district use hand pumps for potable water. Around 16.11% of the housing units use piped water for drinking purposes, majority of which have the facility in their houses. Hardly 1.04% households use potable water taken out from wells whereas other 2.24% use water sources such as ponds etc for drinking purpose.

Groundwater is an important source of drinking water in the project area. Almost every house in the area has a hand pump. It was observed that drinking water from most of these sources is sweet and of good quality.

### 4.3.7 Health

Major health problems in the area are gastroenteritis, acute respiratory infection (ARI), malnutrition, anemia, eczema, fever, and general aches and pains. There are one Basic Health Units (BHU) and one dispensary in the project area. Due to the proximity of the project area to the city of Ghotki, the residents of the study area have access to public as well as private health care. A map indicating a detailed health status is shown in **Exhibit 4.9**.

#### 4.3.8 Education

The overall literacy rate for Ghotki is 29.01%. The female literacy rate is 11.85% as against male literacy of 44.21%. The literacy rate for both male and female is much higher in urban areas as compared to the rural areas. The average rural literacy rate for both sexes is 49.38%, while the average urban literacy rate is 24.87%.

The field survey revealed that the male literacy rate is 67% and the female literacy rate is 32% in the project area, compared to Ghotki where 44.21% of the men and 11.85% of the women are educated (Population Census Organization, 2000). The literacy profile of the project area is shown in **Exhibit 4.10**.

The statistical difference of literacy rate between the survey report and the available data of population census report is partly due to the varying temporal and spatial scopes. Population census report presents a general picture of the whole district while the survey is restricted to the project area as defined above. Census report does not show the current literacy level of the area while survey has been conducted recently, drawing on the up to date information on literacy which is for the most part is extracted from primary sources. The school profile map of the area is also shown in **Exhibit 4.9**.

#### 4.3.9 Infrastructure

All the villages in the project area have electricity and are accessible by blacktop roads. Vans, pickups, and buses provide regular transport service in the area. Telephone facilities are available in all the villages, but there is no gas supply except for few villages. 540 houses in the project area are properly looped with modern electronic media while 140 household have cable services in addition to direct TV broadcast. **Exhibit 4.11** presents the village profile in terms of access to media.

#### 4.3.10 Gender Analysis

Gender analysis defines the evolving socioeconomic roles and functions of men and women as they relate to and complement each other within a specific socio-cultural and economic context. This section describes the roles and responsibilities of women in the project area. Women's access to and control over resources, access to health, education, and a means of livelihood are also addressed.

##### ***Activities Performed by Women***

Women have the major role of addressing food security and nutritive well-being at the household level. From dawn to dusk day of a woman of the project area entails tough and strenuous working schedule. She wakes up at dawn and retires at 9:00 pm. The activities performed by women include working in the fields, cooking the daily meal itself, dishwashing, feeding and milking the livestock, fetching the drinking water, collecting fuel wood, rearing the children, washing the clothes, and taking care of the sick.

In some villages, women fetch water from a distance of 2-4 km. After completing their morning chores, some of them also bring their livestock to the watercourses for drinking.

### **Female Education and Awareness**

The female population of the project area is largely illiterate, and there is very little awareness among them of the importance of formal education.

### **Domestic Violence**

Domestic violence was reported in the area. However, issues regarding women were not openly discussed despite the fact that they constitute one of the main sources of conflict in the area. Violence against women, such as *karo kari* (honor killing [sic]), is not reported regularly. Eighty percent of the cases are actually land, theft, and property related. Disputes are resolved mainly by the elders of the village. *Chiefs of the area* locally known as Chaudhry, Sardar are consulted when the dispute is not resolved by the elders of the village. The locals avoid reporting such matters to the police, preferring the local system of conflict resolution.

### **Gender Discrimination**

The term ‘gender discrimination’ refers to behavioral differences towards males and females that are culturally based and socially learned. Beginning with the negative reaction elicited by the birth of a girl, the presence of this discrimination is demonstrated by the reluctance to provide girls with adequate diet, health treatment, clothing, and other privileges that might incur expenditures on their behalf. Questions regarding dietary patterns, medical treatments, as well as ownership were asked of the female respondents, who confirmed the existence of discrimination against women in these matters in the project area.

#### **4.3.11 Cultural and Archeological Resources**

The only major archeological site in the project area is the ‘*Sant Satra*’ tomb and temple that is located in Raharki, approximately 3 km northwest of the project site. This is a significant Hindu archeological site which is visited by thousands of Hindus from Pakistan and abroad. Many Muslims of the surrounding areas also visit the site.

**Exhibit 4.1: Seasonal Characteristics of Climate of the Project Area**

<i>Season</i>	<i>Temperature</i>	<i>Humidity</i>	<i>Rainfall</i>	<i>Wind</i>
Summer (Mid March to mid June)	March is the transition period from winter to summer. Daily maximum increases from about 27°C at the start of the month to 34°C at the end. It continues to increase and peaks at 44°C just before the onset of monsoon in late June.	Morning (Evening) humidity decreases from 65% (28%) in March to about 52% (23%) by mid April. It stays around this figure for about a month and starts increasing in late May and reaches 65% (25%) by June.	5-7 mm of rain falls in February. The rest of the season is dry—monthly rainfall is less than 5 mm.	Wind starts changing direction, from NE to S-SW, near the end of March. The average speed also increases from 3 knots to 4.5 knots by mid June.
Monsoon (Mid June to mid September)	High winds and subsequent rainfall lowers the temperature by 4-5°C in July. The maximum temperature remains around 38°C in August and September.	Moisture associated with monsoon increases humidity to more than 75% in the morning and 40% in the evening during July, August and most of September.	More than 55 mm of rain falls during this period; this accounts for more than 60% of the total rainfall received in the area.	Throughout this period, wind blows from the south at an average speed of 3.5 knots.
Post-Monsoon Summer (Mid September to November)	The daily maximum temperature drops by more than 10°C from early October to end of November.	Morning (evening) humidity decreases slightly; however, it remains above 70% (30%).	The season is dry. Monthly average rainfall is less than 5 mm.	Average wind speed drops below 2.5 knots. The direction starts changing back to NE by the end of September.
Winter (December to mid March)	The daily maximum and minimum temperatures averages around 24° and 9°C, respectively.	Morning (Evening) humidity increases to nearly 75% (35%) in December but drops to 65% (30%) by end of February.	The season is dry. Monthly average rainfall is less than 5 mm, except February when 5-7 mm of rain is received in the project area.	Mild wind (less than 2.5 knots) blows from northeast throughout this season.

**Exhibit 4.2: Monthly Temperature Data for Sukkur (in °C)**

Month	Mean Daily		Maximum Recorded		Minimum Recorded	
	Maximum	Minimum	Value	Date	Value	Date
January	22.8	8.4	31	25/1932	-4	31/1929
February	25.3	10.9	38	27/1953	-1	01/1929
March	31.2	16.4	42.2	16/1969	4	02/1936
April	37.6	22.0	47	28/1979	10	03/1989
May	42.4	26.2	49	29/1981	16	08/1989
June	43.6	28.4	50	11/1979	19	13/1990
July	40.8	27.9	47	02/1976	17.5	26/1989
August	38.7	26.7	47	09/1987	17.5	28/1989
September	38.0	24.9	43.3	23/1968	16.5	27/1989
October	35.3	20.3	44	05/1951	9.5	28/1989
November	29.9	14.4	38	06/1990	5	30/1938
December	24.0	9.6	33	01/1953	-1.5	15/1986

**Source:** Pakistan Meteorological Department (1992)

**Exhibit 4.3: Mean Monthly Relative Humidity at Sukkur**

Month	Relative Humidity at 5:00 am (%)	Relative Humidity at 5:00 pm (%)
Jan	73	35
Feb	67	32
Mar	63	28
Apr	52	22
May	52	20
Jun	65	26
Jul	75	40
Aug	77	46
Sep	77	41
Oct	71	32
Nov	74	34
Dec	76	38

**Source:** Pakistan Meteorological Department (1992)

**Exhibit 4.4:** Demographic Data of the Study Area

	<i>Households</i>	<i>Population</i>	<i>Household Size</i>
Bagho Bhutto	350	2,500	7.1
Kotla Mirzan	30	300	10.0
Jhando Bughio	50	300	6.0
Jan Mohammad Bughio	600	5,000	8.3
Qaloo Buriro	170	1,500	8.8
Jhung	1,000	8,000	8.0
Sajan Malik	15	150	10.0
Shanawaz Buriro	300	2,500	8.3
Nathu Bhutto	50	500	10.0
Nur Hasan Shah	65	700	10.8
<b>Total</b>	<b>2,630</b>	<b>21,450</b>	<b>8.2</b>

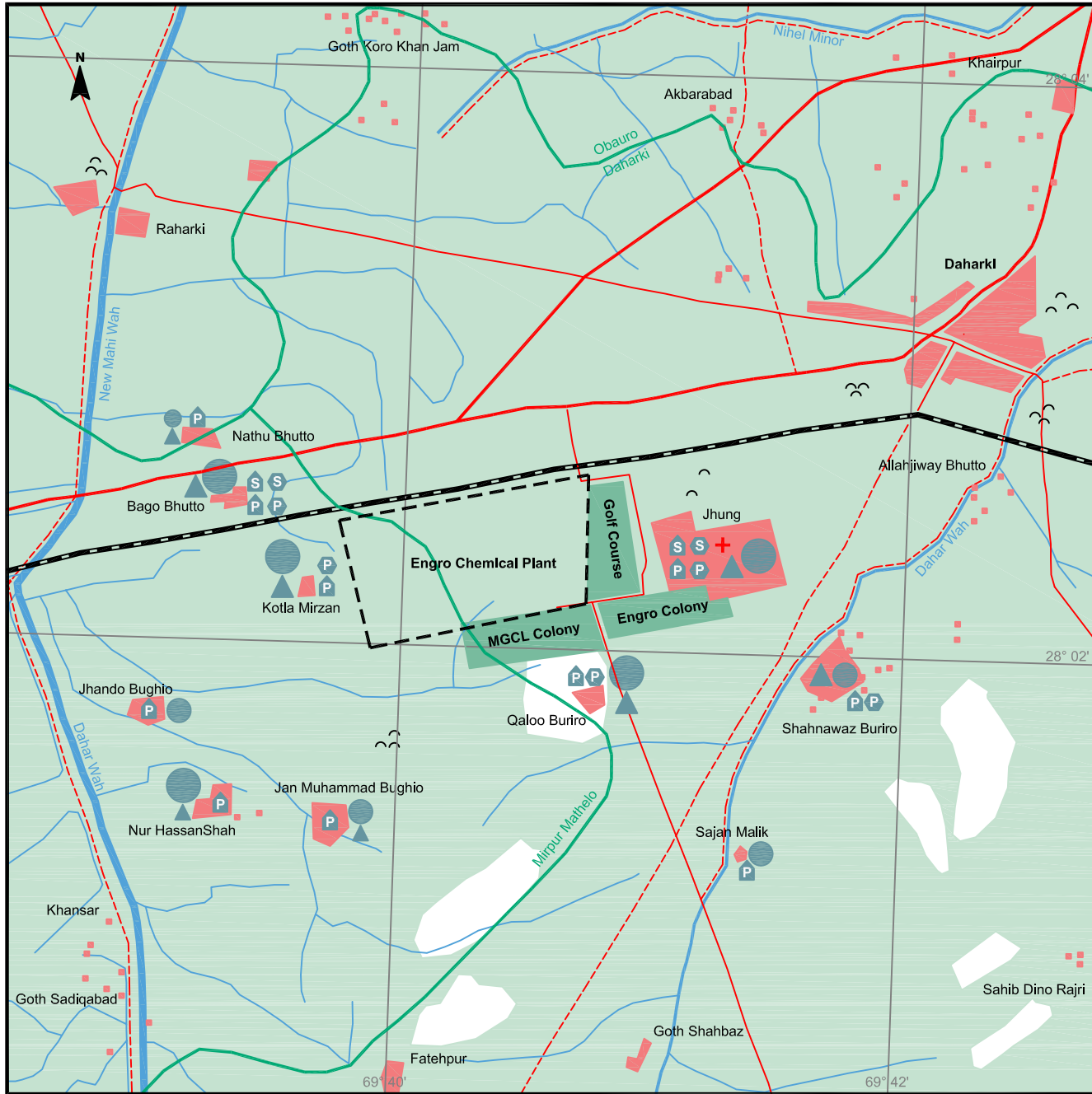
**Exhibit 4.5:** Agricultural Field in the Project Area

**Exhibit 4.6:** Rural Settlement in the Project Area**Exhibit 4.7:** Administrative Association of Settlements in the Study Area

<i>Village</i>	<i>Deh</i>	<i>Taluka</i>	<i>Union Council</i>
Bagho Bhutto	Jhung	Daharki	Daharki
Kotla Mirzan	Jhung	Daharki	Daharki
Jhando Bughio	Jhung	Daharki	Daharki
Jan Mohammad Bughio	Jhung	Daharki	Daharki
Qaloo Buriro	Jhung	Daharki	Daharki
Jhung	Jhung	Daharki	Daharki
Sajan Malik	Wahi Gul Khan	Daharki	Daharki
Shanawaz Buriro	Wahi Gul Khan	Daharki	Daharki
Nathu Bhutto	Raharki	Daharki	Raharki
Nur Hasan Shah	Khansar	Mirpur Mathelo	UC 2

**Exhibit 4.8: Sources of Income in the Study Area**

	<i>Agriculture</i>	<i>Service (Private and Government)</i>	<i>Others</i>
Bagho Bhutto	50%	40%	10%
Kotla Mirzan	80%	10%	10%
Jhando Bughio	90%	5%	5%
Jan Mohammad Bughio	55%	40%	5%
Qaloo Buriro	70%	20%	10%
Jhung	20%	60%	20%
Sajan Malik	80%	15%	5%
Shanawaz Buriro	70%	10%	20%
Nathu Bhutto	50%	40%	10%
Nur Hasan Shah	80%	5%	15%



**Legend**

- Highway
- Metalled Road
- Jeepable Track / Trail
- Railway Line
- Taluka Boundary
- Canals
- Settlement
- Graveyard
- Basic Health Unit

**Literacy Rate in %**

Literacy Rate	Male	Female
> 70	Large Blue Circle	Large Blue Triangle
30 - 70	Medium Blue Circle	Medium Blue Triangle
< 30	Small Blue Circle	Small Blue Triangle

**Schools**

School Type	Male	Female
Secondary	S in a circle	S in a circle
Primary	P in a circle	P in a circle

0 500 1000 1500 Meters

**EIA of ECPL Expansion Project**

**Exhibit 4.9**  
**Education and Health**

<b>Scale</b>	1 : 40,000
<b>Source</b>	SoP and Field Visit
<b>Drawing</b>	W7E03DEE
<b>Date</b>	May 2007
<b>Client</b>	Engro Chemicals Pakistan Limited

Hagler Bailly Pakistan

**Exhibit 4.10: Literacy Profile and Educational Services of the Project Area**

	<i>Male Literacy Rate (%)</i>	<i>Female Literacy Rate (%)</i>	<i>School for Boys</i>	<i>School for Girls</i>
Bagho Bhutto	90	70	one primary and one middle school	one primary and one middle school
Kotla Mirzan	80	50	one primary school	one primary school
Jhando Bughio	50	0	one primary school	No
Jan Mohammad Bughio	70	10	one primary school	No
Qaloo Buriro	70	40	one primary school	one primary school
Jhung	90	70	one primary and one middle school	one primary and one middle school
Sajan Malik	50	0	one primary school	No
Shanawaz Buriro	70	40	one primary school	one primary school
Nathu Bhutto	25	15	one primary school	No
Nur Hasan Shah	80	20	one primary school	No

**Exhibit 4.11: Community Access to Media**

	<i>TV</i>	<i>Cable</i>	<i>Dish</i>	<i>Newspaper</i>	<i>Telephone (Houses)</i>	<i>Mobiles (Adult)</i>
Bagho Bhutto	100	80	0	20	60	90
Kotla Mirzan	90	–	–	–	30	60
Jhando Bughio	20	–	–	–	0	5
Jan Mohammad Bughio	60	60	–	60	5	70
Qaloo Buriro	60	–	5	60	25	70
Jhung	90	–	–	–	70	90
Sajan Malik	0	0	0	–	0	30
Shanawaz Buriro	60	–	–	–	25	70
Nathu Bhutto	50	–	–	–	20	45
Nur Hasan Shah	10	–	–	–	0	15

**Note:** ‘–’ Indicates that the data is not available.

## 5. Analysis of Alternatives

---

This section describes the various project management and design alternatives that were examined during the preparation of the feasibility report and the environmental and social impact assessment reports.

### 5.1 Management Options

The management alternatives examine the no-action option that means not installing the proposed plants and bringing no change to the baseline scenario. This option is discussed below:

#### 5.1.1 No-Action

The 'no-action' option if taken will prevent the country from increasing its production of urea fertilizer and result in greater imports to meet the growing demands of urea fertilizer in the country. The proposed activity will provide relief to the government as it provides considerable subsidy on imported urea and offers a chance to improve Pakistan's trade deficit and offer reliable and economical supply of indigenously produced urea fertilizer to Pakistan's agricultural sector.

Furthermore, the no-action option will result in loss of employment as the proposed activities are bound to create more jobs, a loss of opportunity in transfer of technology to Pakistan, and a loss of opportunity for the economic growth of the country.

### 5.2 Alternative Technology Options

Out of the several urea and ammonia plant technology providers, ECPL has opted to procure the technology of Snamprogetti S.p.A of the Eni Group Italy for their urea fertilizer manufacturing facility and its ancillary ammonia plant. Snamprogetti S.p.A is the world leading technology provider for fertilizer manufacturing and everyday over 132,000 tons of urea fertilizer is produced by plants using Snamprogetti technology. Snamprogetti technology is also a tried and tested technology in Pakistan with the Fauji Fertilizer Company, the Pak-Arab Fertilizer Company, and the National Fertilizer Company already employing Snamprogetti technology.

The main process of producing urea fertilizer is the same for most technology providers; however, the Snamprogetti technology has several salient features that resulted in ECPL opting for this technology. These salient features are discussed in the following section.

#### 5.2.1 Salient Features of the Selected Option

The main reasons for the selection of the Snamprogetti urea and ammonia plants are:

- ▶ **Reduced water requirement:** The proposed plants will use 25 % of process water as compared with the existing urea and ammonia plants. This is due to the

proposed plants improved water recycling and loss reduction features. Furthermore, the plant will have a Reverse Osmosis (RO) unit instead of a lime softening unit, this will result in much lesser effluent as compared with previous technologies.

- ▶ Reduced air emission: In earlier technologies process upsets at the ammonia plant would result in direct venting of gas into the atmosphere, while in the proposed design gases in process upsets would be burnt in flares. Furthermore, combustions emissions from the plant will also be lower as the Snamprogetti technology is one of the most energy efficient ones available at this time.
- ▶ It is a proven technology as it is the worldwide market leader therefore availability of personnel that have worked on similar technology would be easier.

## 6. Stakeholder Consultation

---

This section describes the outcomes of the stakeholder consultation process as part of the impact assessment. The consultation was initiated at the early stage in the project cycle. This ensures that feedback from communities and other stakeholders directly or indirectly affected by the project can be used to adjust and improve the project's design, planning, and implementation, and help structure of the project to be both environmentally and socially sound

### 6.1 Objectives of Stakeholder Consultation

The main objective of the stakeholder consultation process was to disseminate information on the project and its expected impact, long-term as well as short-term, among primary and secondary stakeholders, and to gather information on relevant issues so that the feedback received could be used to address these issues at an early stage. Another important objective was to determine the extent of the negative impact of different project activities and suggest appropriate mitigation measures.

### 6.2 Identification of Stakeholders

Stakeholders are people, groups, institutions, or industrial units that may be affected by, can significantly influence, or are important to the achievement of the stated purpose of a proposed intervention. Following are two categories of stakeholders were identified:

- a. *Primary Stakeholders:* People, groups or institutions affected positively or negatively by the project
- b. *Secondary Stakeholders:* People, groups, or institutions that are important intermediaries in the project delivery process

### 6.3 Stakeholder Consultation Process

Stakeholder consultation for this study was planned in two stages. The first stage, which has already taken place, consisted of meetings with individuals, groups, relevant organizations and government departments, which are in some way linked to the project and therefore considered stakeholders. The meetings were conducted to inform stakeholders about the project and how it may affect their lives/activities, and to record their concerns, whether real or perceived. Through the use of various tools—such as participatory needs assessment, community consultation meetings, focus group discussions, one-on-one meetings, and rapid rural assessments—the study team tried to involve the stakeholders in active decision-making. The results of this exercise are described below, where mitigation measures have been given to address pertinent stakeholder concerns.

At second stage of the stakeholder consultation the results of this study and the proposed mitigation measures for potential social impacts will be disclosed to stakeholders. The

disclosure of results will be in the form of a workshop for organizations and departments, and meetings with groups and individuals living on or near the project site.

It is to be noted that before this stakeholder consultation ECPL also conducted a socioeconomic survey as a part of their independent Community Awareness and Emergency Response (CAER) program. The survey was conducted to assess the needs of primary stakeholders.

## **6.4 Primary Stakeholders Consultation**

### **6.4.1 Topics for Discussion**

Given below is a list of the topics that were covered during the meetings.

- ▶ Employment
- ▶ Pollution
- ▶ Water
- ▶ Community development
- ▶ Traffic
- ▶ Non-local workforce
- ▶ Gender issues

The project site is located within the boundary of the existing plant, therefore the issues related to land acquisition and compensation and displacement and involuntary settlement were not discussed.

Key project stakeholders and their project-related interests are given in **Exhibit 6.1**. Based on the stakeholders identified, the consultations process was determined.

### ***Consultation Process***

The consultants held meetings with primary stakeholders. To assess any potential gender issues that could be raised due to the project activities separate consultations were held with the females of the nearby villages. The survey team visited ten villages in total that may be affected from the activities of the proposed project. **Exhibits 6.2** shows photograph of one of these consultations.

During these consultations a simple, non-technical description of the project was given, along with an overview of the project's likely human and environmental impact. Following the project description, a discussion was held so that the participants can voice their concerns and opinions. These concerns and suggestions were recorded in field notes.

### **6.4.2 Outcomes of Consultations**

**Exhibit 6.3** summarizes the issues and concerns raised by the community and how the concerns will be addressed.

## **6.5 Meetings with Secondary Stakeholders**

Management of the relevant secondary stakeholders (institutions) was met at their respective offices regarding the consultation. A list of participants and institutions is shown in **Exhibit 6.4**. Photograph showing a secondary stakeholders consultation is shown in **Exhibit 6.5** and outcomes of consultations are summarized in **Exhibit 6.6**. A brief description of the consultation process is given below.

### **6.5.1 Consultation with Mari Gas Company Limited (MGCL)**

Consultation with the Managing Director of MGCL, Lt. Gen. (retd.) Imtiaz Shaheen was held at the MGCL head office in Islamabad on June 15, 2007. Gen. Shaheen expressed his apprehensions about the safety of the surrounding communities due to plant expansion. In his opinion, the expansion of the plant will result in the creation of a 'Hazard Mass' at the ECPL site that will exceed a critical level and consequently will not be safe for the surrounding communities. He was also concerned about the increase in noise due to the expansion project particularly that from venting during plant shutdown.

On a broader issue, he thought that strategically it is not wise to allow so many projects (fertilizer and power) in the narrow belt between the cities of Rahim Yar Khan and Ghotki.

### **6.5.2 Consultation with Governmental Institutions and Community Representatives**

#### ***Area Water Board***

Area water board is an outcome of current reforms in irrigation system. A meeting with Mr. Ghulam Hussain Chachr, chairman area water board, was held in his office. The Chairman Water Board is a volunteer position nominated through elections. The concept of the board is to manage water distribution at down the canal levels. The board is comprised with a team of 12 members representing different fractions of society.

#### ***Irrigation and Power Department***

A meeting with Mr. Akhtar Leghari, Assistant Executive Engineer of the department in the area was held in his office in the absence of executive engineer. He welcomed projects like the proposed expansion plant and considered them good for the development of the project area in particular and the country, in general. He, however, insisted that environmental degradation associated with such activities should also be taken into account while designing the project. He also clarified that the Irrigation Department would allow the project to use the water from the irrigation canals after due permission from the department.

#### ***Sindh Environmental Protection Agency (Sindh-EPA)***

A meeting with Mr. Waqar Hussain, deputy director for Sukkur region was held in EPA office in Sukkur. He indicated a list of NGOs working in the area for consultation.

### ***National Commission on Human Development (NCHD)***

NCHD is a semi private organization working in the sectors of education, health and community development. The organization also departs training to district administration. A meeting with Mr. Tufail Solangi, Manager Finance and Administration of the organization was held in his office located at Mirpur Mathello.

Maximum employment to the people of the local community is a general concern of the community, although there is a good contribution from ECPL in the development of community in the surroundings of the plant. It should also be ensured that emissions and effluents have no any direct or indirect impact on the community and local resources of the area. The use of local water may not have any adverse impact on groundwater availability as the water is abundant for local use

### ***UC Nazim Daharki***

Consultation with Mr. Mian Manzoor, Nazim of Union Council Daharki was held at his residence. He said that UC administration is happy to know about the proposed expansion plan because we expect that the new plant will open up new opportunities of employments to the local community. ECPL already has good contributions in the area's development especially in health and technical education.

He suggested that ECPL should undertake an expert study for impacts of normal and abnormal emissions from the existing and future plants on the community of the area and the results of study should be shared with the community. A community level response plan should also be developed and communicated to the community. A similar study should also be conducted to assess the wastewater impacts on groundwater and soil. The public of the area complaints that the higher rate of Hepatitis in the area is correlated with the wastewater disposal from ECPL's existing plant therefore ECPL should also establish through a detailed study that there is no correlation of Hepatitis and wastewater discharged from ECPL plant. The results of the study should also be shared with the community for the awareness.

### ***UC Nazim Raharki***

A meeting with UC Nazim Raharki Mr Jam Fateh was held at his office. He said that previously when there were excessive emissions of ammonia, the diseases like cough, allergies and eye irritation were high and there was a visible effect on crops and other vegetation of the area. But now the emissions are reduced and such cases are not noticed. Plant effluent discharge is directly affecting villages in the surroundings including Goth Jan Muhammad Bhagio, Goth Kotla Mirza, Goth Jhung and Goth Kalo Burero. He recommended following measures to be taken during expansion:

- ▶ An efficient wastewater treatment plant
- ▶ Removal of existing ponds
- ▶ Employment to locals also at the management levels
- ▶ Community development projects like hospitals, schools, play grounds,
- ▶ All purchasing from local market

- ▶ Maximum social investments only on local community not to organizations operating outside the area

### **6.5.3 Consultation with NGOs and CBOs**

Three prominent organizations were consulted during the process. A brief description of process is given below

#### ***Worldwide Fund for Nature (WWF) Sukkur***

A meeting with Saeed Ahmed Daho, Project officer Indus River Dolphin Conservation Project (IRDCP) was held at the project office in Sukkur. ECPL is currently funding the WWF project on the conservation of Indus water dolphins. Mr Daho recommended the following measures:

- ▶ Wastewater disposal should be environmental friendly and each type of waste should be treated before disposal
- ▶ Waste should be recycled where possible
- ▶ Gas emissions to be controlled
- ▶ Plantation of indigenous species should be considered as an ongoing process. Neem tree should be planted which work as a medicinal plant and as organic pesticide.
- ▶ A community environment awareness program can also be initiated through schools in the area.

#### ***Mari Stopes Society***

Mari Stopes Society (MSS) is a Non-Governmental Organization (NGO) funded by a Canadian organization. A meeting with Samreen Khan, district marketing manager was held at MSS office. The Mari Stopes Society was established in 2003 in Ghotki district. MSS is currently working in the area. Ms Khan said that ECPL is a socially responsible organization that supports MSS through providing resources and facilitates for our activities in the villages located in the vicinity of plant. Mari Stopes uses ECPL's existing medical centre for free medical camps for education, vaccination and other ailments.

#### ***Jhung Welfare Organization***

A meeting with Mumtaz Ali (President), Muhamad Qasim (Accountant), and Barkat Ali (Member) was held in office of the organization. This is a community based organization registered in 1997 as a social welfare organization in Sukkur. ECPL's assistance to the organization is on top since very beginning. Major investments of the ECPL include improvement of sewerage system, school repairing and maintenance, drinking water supply and improvement, and assistance in programs health. Further assistance is also expected. The organization is happy with the ECPL's expansion plan as more employment will be created to the community of the village and the area.

#### **6.5.4 Consultation with Industries**

Two industries were successfully consulted during the process. Employees Union of ECPL is considered as stakeholders of the project therefore a meeting with the management of the union was also held. The brief description of the consultation process with the industries given below:

##### ***Fauji Fertilizer Company Limited (FFCL)***

An informal meeting with Sohail Khalid Khawaja (Unit Manager Process Engineering), and Akbar Fida (Safety Head) was held in FFCL plant in Mirpur Mathello. The participants clarified that the comments on behalf of company can be made only by higher management in corporate office, therefore the discussion should be treated as a technical advice from engineering and HSE departments.

The route of proposed pipeline should ensure FFCL plant safety in case of any accident and reasonably safe distance should be maintained. The labor and trucks are limited in the area; therefore ECPL should inform FFCL during shutdown, maintenance process and other non-routine operations for hiring of local trucks and local labor. ECPL should have a disaster management plan for emissions of ammonia and chlorine release and pressurized storage.

##### ***Liberty Power***

A meeting with M. Shahid Nadeem, Safety and Training Officer was held in his office at the plant. He said that the existing complaint response and redressal system is efficient. Emergency ammonia release, storage and evaporation are potential concerns. Effluent and evaporation ponds are general concerns of the community in the area. A study of urea dust dispersion should be conducted. Chlorine and other chemicals should also be studied. The response guidelines should be provided to Liberty.

##### ***ECPL's Employee's Union***

Gul Hussain Dahar (President) and Ghulam Sarwar Soomro (Junior Vice President) and Aftab Beig (Vice President) were consulted during the plant visit. They said that there are specific demands. ECPL is employee friendly company. Some minor concerns include long working hours and overtime not being paid by the contractors to the contract labor. ECPL should force its contractors to maintain the ECPL's standards in terms of salary and working hours. The cotton factories near ECPL plant are emitting dust that is directly affecting the health of the local settlements therefore ECPL should support community complaints on these cotton factories.

**Exhibit 6.1:** List of Participants of Primary Stakeholders Consultation

<i>Name of Village</i>	<i>Respondent</i>
Bagho Bhutto	Abdus Sami son of Abdul Majid Faize Mohammad son of Jumma Khan
Kotla Mirzan	Mohammad Yunus son of Khair Mohammad
Jhando Bughio	Amir Din son of Jando Bughio
Qaloo Buriro	Haji Abdul Qayoom
Jhung	Abdul Wahid Mangi son of Ghulam Nabi Senior Vice President City Daharki Asian Human Rights Development Organizations
Sajan Malik	Wadero Ziab Din son of Dolat Khan Ali Raza son of Gul Hasan
Nathu Bhutto	Abdul Wahid and Nazir Ahmad sons of Mohammad Khuda Bux
Nur Hasan Shah	Nawab Ali Shah Kazmi son of Syed Ghulam Hussain Shah State Life Area Manager

**Exhibit 6.2:** Primary Stakeholders Being Consulted



### Exhibit 6.3: Concerns Raised by Stakeholders and Mitigation

<i>Area of Concern</i>	<i>Observation of the Community/Concern Expressed</i>	<i>Proposed Mitigation</i>	<i>EIA Section where the Concern/ Suggestion is Addressed</i>
Employment	Technical jobs for which local labor can compete may not be given to people from outside the project area	<p>Maximum number of unskilled and semi-skilled jobs will be reserved for the local communities</p> <p>A local labor selection criterion will be developed in consultation with the community</p>	Section 3
Project Benefits	The project should benefit the poor community of the area.	<p>A local labor selection criterion will be developed in consultation with the community.</p> <p>Community welfare programs will be initiated.</p>	Section 3 and Section 7
Community Health	Emissions from the plant during operational phase, may affect the ambient air quality in the area.	To assess the impact on the ambient air quality, the increase in concentration of pollutants in the ambient air due to emission from the stack of the plant is assessed and appropriate mitigation measures are incorporated in the project design.	Section 7

**Exhibit 6.4:** List of Secondary Stakeholders and Participants

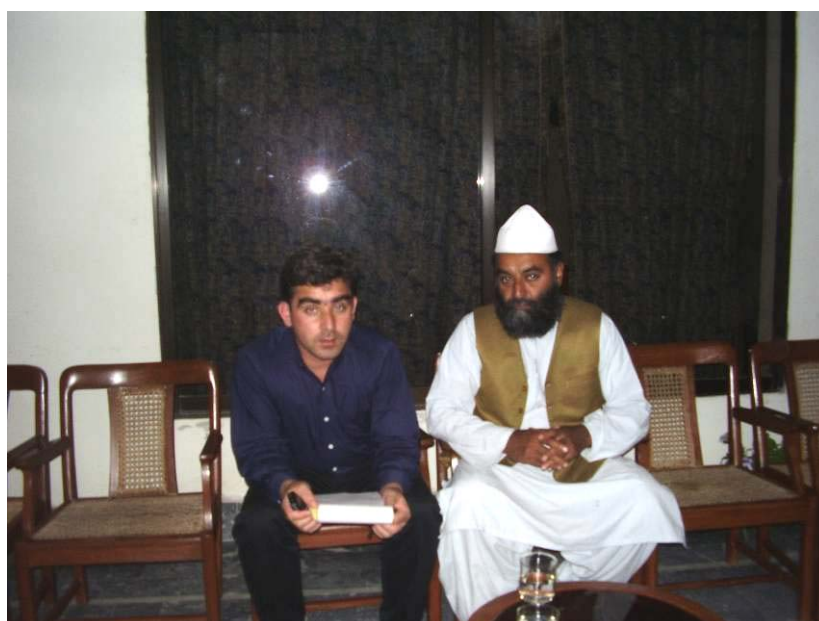
No	Organization	Respondent (s)	Designation	Type and Activities of the Organization
1	Mari Gas Company Limited	Lt Gen (retd) Imtiaz Shaheen	Managing Director	MGCL is an oil and gas exploration and production company
2	National Commission on Human Development (NCHD)	Tufail Solangi	Administration and Finance Manager Mirpur Mathello	NCHD is a semi private organization working in the sectors of education, health and community development. The organization also departs training to district administration
3	Worldwide Fund for Nature (WWF) Sukkar	Saeed Ahmed Daho	Project officer IRDCP	An international non governmental organization working for the conservation of environment and wildlife
4	Jhung Welfare Association	Mumtaz Ali	President,	A community based organization registered in 1997 as a social welfare organization in Sukkur
		Muhammad Qasim	Accountant,	
		Barkat Ali	Member	
5	Area Water Board	Ghulam Hasan Chachar	Chairman	Area water board is an outcome of current reforms in irrigation system. Chairman water board is volunteer position nominated through elections. The concept of the board is to manage water and distribution at down the canal levels. A board comprising of a team of 12 members representing deferent fractions of society.
6	UC Nazim Daharki	Mian Manzoor	UC Nazim Dhahrki City	Geverment Administration
7	UC Nazim Reharki	Jam Fateh	UC Nazim Raharki	Geverment Administration
8	Sindh-EPA			
9	Sindh Water and Irrigation Department	Akhtar Leghari	Assistant Executive Engineer	Government Organization

*Continues...*

...Continued

No	Organization	Respondent (s)	Designation	Type and Activities of the Organization
10	Fauji Fertilizer Company Limited (FFCL)	Sohail Khalid Khawaja	Unit Manager Process Engineering	The respondent clarified that the comments on behalf of company can be made only by higher management in corporate office therefore the discussion should be treated as a technical advise from engineering and HSE departments
		Akbar Fida	Safety Head	
11	Liberty Power	M. Shahid Nadeem	Safety and Training Officer	Independent Power Plant at Mirpur Mathello
12	Mari Stopes Society	Samreen Khan	Marketing Manager, District Ghotki	Mari Stopes Society is a Non-Governmental Organization (NGO) funded from a Canadian organization is established in 2003 in Ghotki districts
13	ECPL Employs Labor Union	Ghulam Sarwar Soomro	Junior Vice President	Employees Welfare Union
		Gul Hussain Dahar	president	
		Aftab Beig	vice president	

**Exhibit 6.5:** Consultation with Secondary Stakeholders In-progress



**Exhibit 6.6: Summarized Outcomes of the Stakeholder Consultation**

No	Organization	Type and Activities of the Organization	Concerns	Response from ECPL and Mitigation Measures
1	Mari Gas Company Limited	MGCL is an oil and gas exploration and production company	Hazard for the surrounding communities due to the storage and use of ammonia was the major concern raised. MGCL also raised the concern regarding increase in noise due to the expansion project and particularly from the venting process during plant shutdown	Section 7
2	National Commission on Human Development (NCHD)	NCHD is a semi private organization working in the sectors of education, health and community development. The organization also departs training to district administration	Maximum employment to the people of the local community is a general concern of the community, although there is a good contribution from ECPL in the development of community in the surroundings of the plant. It should also be ensured that emissions and effluents have no any direct or indirect impact on the community and local resources of the area. The use of local water may not have any adverse impact on groundwater availability as the water is abundant for local use	Section 3 and Section 7
3	Worldwide Fund for Nature (WWF) Sukkar	An international non governmental organization working for the conservation of environment and wildlife	Wastewater disposal should be environmental friendly and each type of waste should be treated before disposal. Waste should be recycled where possible. Gas emissions to be controlled. Plantation of indigenous species should be considered as an ongoing process. Neem tree should be planted which work as a medicinal plant and as organic pesticide. A community environment awareness program can also be initiated through schools in the area.	Section 7

*Continues...*

... Continued

No	Organization	Type and Activities of the Organization	Concerns	Response from ECPL and Mitigation Measures
4	Jhung Welfare Association	A community based organization registered in 1997 as a social welfare organization in Sukkur	ECPL's assistance to the organization is on top since very beginning. Major investments of the ECPL include improvement of sewerage system, school repairing and maintenance, drinking water supply and improvement, and assistance in programs health. Further assistance is also expected. The organization is happy with the ECPL's expansion plan as more employment will be created to the community of the village and the area	Section 3 and Section 7
5	Area Water Board	Area water board is an outcome of current reforms in irrigation system. Chairman water board is volunteer position nominated through elections. The concept of the board is to manage water and distribution at down the canal levels. A board comprising of a team of 12 members representing different fractions of society.	ECPL should seek prior approval from area water board to extract groundwater from the area. The application for approval should be processed through Sindh Irrigation and Power department.	Section 3 and Section 7

Continues...

... Continued

No	Organization	Type and Activities of the Organization	Concerns	Response from ECPL and Mitigation Measures
6	UC Nazim Daharki	Government Administration	He suggested that ECPL should undertake an expert study for impacts of normal and abnormal emissions from the existing and future plants on the community of the area and the results of study should be shared with the community. A community level response plan should also be developed and communicated to the community. A similar study should also be conducted to assess the wastewater impacts on groundwater and soil. The public of the area complains that the higher rate of Hepatitis in the area is correlated with the wastewater disposal from ECPL's existing plant therefore ECPL should also establish through a detailed study that there is no correlation of Hepatitis and wastewater discharged from ECPL plant. The results of the study should also be shared with the community for the awareness.	Section 7
7	UC Nazim Raharki	Government Administration	An efficient wastewater treatment plant. Removal of existing ponds. Employment to locals also at the management levels. Community development projects like hospitals, schools, play grounds. All purchasing from local market. Maximum social investments only on local community not to organizations operating outside the area	Section 7
8	Sindh-EPA	Mr. Waqar Hussain, deputy director for Sukkur region	He indicated a list of NGOs working in the area for consultation	

Continues...

... Continued

No	Organization	Type and Activities of the Organization	Concerns	Response from ECPL and Mitigation Measures
9	Sindh Water and Irrigation Department	Government Organization	He welcomed projects like the proposed expansion plant and considered them good for the development of the project area in particular and the country, in general. He, however, insisted that environmental degradation associated with such activities should also be taken into account while designing the project. He also clarified that the Irrigation Department would allow the project to use the water from the irrigation canals after due permission from the department.	Section 3
10	Fauji Fertilizer Company Limited (FFCL)	The respondent clarified that the comments on behalf of company can be made only by higher management in corporate office therefore the discussion should be treated as a technical advise from engineering and HSE departments	The route of proposed pipeline should ensure FFCL plant safety in case of any accident and reasonably safe distance should be maintained. The labor and trucks are limited in the area; therefore ECPL should inform FFC during shutdown, maintenance process and other non-routine operations for hiring of local trucks and local labor. ECPL should have a disaster management plan for emissions of ammonia and chlorine release and pressurized storage.	Section 7

Continues...

... Continued

No	Organization	Type and Activities of the Organization	Concerns	Response from ECPL and Mitigation Measures
11	Liberty Power	Independent Power Plant at Mirpur Mathello	A meeting with M. Shahid Nadeem, Safety and Training Officer was held in his office at the plant. He said that the existing complaint response and redressal system is efficient. Emergency ammonia release, storage and evaporation are potential concerns. Effluent and evaporation ponds are general concerns of the community in the area. A study of urea dust dispersion should be conducted. Chlorine and other chemicals should also be studied. The response guidelines should be provided to Liberty	Section 7
12	Mari Stopes Society	Mari Stopes Society is a Non-Governmental Organization (NGO) funded from a Canadian organization is established in 2003 in Ghotki districts	Ms Khan said that ECPL is a socially responsible organization that supports MSS through providing resources and facilitates for our activities in the villages located in the vicinity of plant. Mari Stopes uses ECPL's existing medical centre for free medical camps for education, vaccination and other ailments.	
13	ECPL Employs Labor Union	Employees Welfare Union	Ghulam Sarwar Soomro (Junior Vice President), Gul Hussain Dahar (President) and Aftab Beig (Vice President) were consulted during the plant visit. They said that there are specific demands. ECPL is employee friendly company. Some minor concerns include the long working hours and overtime is not being paid by contractors to the contract labor. ECPL should force its contractors to maintain the ECPL's standards in terms of salary and working hours. The cotton factories near ECPL plant are emitting dust that is directly effecting the health of the local settlements therefore ECPL should support community complaints on these cotton factories	

## 7. Environmental Impacts and Mitigations

---

This section discusses the potential environmental impacts of the proposed activities, predicts the magnitude of the impact, assesses the significance, recommends mitigation measures to minimize adverse impacts, and identifies the residual impacts of the project. The discussion starts with the scoping of the potential issues associated with the construction and operations of the proposed project. The discussions of the environmental impacts are then organized in the following manner:

- ▶ Impacts Associated with construction activities
- ▶ Impacts Associated with plants operations
- ▶ Impacts Associated with decommissioning of plants

### 7.1 Scoping

Environmental scoping is a process by which a decision is taken on whether or not detailed assessment of a potential environmental aspect is required. The environmental scoping process starts immediately after the commencement of the environmental assessment study and continues until the design is finalized. The process follows collection of basic information on the proposed project, the pertinent policies and laws, and the available environmental data. The steps in the evaluation are discussed below.

#### ***Identification of Potential Impacts***

In the first step, potential impacts of the project are identified using professional judgment, published literature on environmental impact of similar projects, environmental guidelines, checklists, and field visits.

#### ***Stakeholders Consultation***

A critical step in identifying potential impacts is consultation with the stakeholders to document their concern. For the proposed project, the consultation was done in two phases. During the survey, the concerns and expectation of all stakeholders of the proposed project were recorded. In the second phase, the impact assessment and suggested mitigations discussed with stakeholders. The results of the stakeholder consultation are included in **Section 6**.

#### ***Receptor Classification***

In the next step, the potential impacts are classified according to the type of potential receptors. The following receptor categories were used:

- ▶ Social (people, their social and cultural values, and aspirations)
- ▶ Land and soil (land resources, soil resources)
- ▶ Air quality (ambient air quality)

- ▶ Water resources (groundwater and surface water resources including seawater)
- ▶ Ecosystem (vegetation, wildlife, and biodiversity).

### **Scoping Criteria**

In the next step, each potential impact is evaluated on the basis of five criteria. The five questions that are asked about each potential impact are:

1. Is there a risk that environmental standards or environmental guidelines applicable to the project will be breached? This includes the national standards such as the NEQS and guidelines such as the IFC environmental guidelines
2. Is this the first time, the study area will be exposed to this type of environmental impact from development activities? Development activities in an area that is generally preserved in its natural state and has limited human activity may result in unexpected consequences and requires careful study
3. Did the stakeholders express any concern about this aspect? If the stakeholders are concerned about a particular aspect, it is essential to assess it in detail
4. Will the quality of life of the community be impacted? Quality of life may include health, social interaction, ability to earn livelihood, or ability to enjoy some use of their property due to nuisance (odor, noise, or lack of hygiene)
5. Is there a high risk of a permanent, irreversible, and significant change to environmental conditions due to the particular project activity? Some impacts are transitory; they last until the activity that is the cause of the impact is there. Others may last much longer than the activity. After a long period the environmental parameter may or may not revert back to its natural state. Such aspects require detailed assessment.

If the answers to all of the above questions are in negative, it is inferred that the issues is not pertinent to the project and no further assessment is necessary. However, if the answer to any one of the criteria question is in positive detailed assessment is undertaken. In cases of some minor impacts, strong design controls or management controls may exist. In such cases, no assessment is undertaken but the continued implementation of the control measure is included in the mitigation and monitoring plan. The areas for which detailed analysis is required are discussed in this chapter.

## **7.2 Impact Assessment Methodology**

Once potential issues have been identified, the impact assessment of each potential issue follows these steps:

1. Definition of the Criteria for Determining Significance

The consequence of the proposed activity is evaluated by comparing it against a recognized Significance Criteria. The criteria are of the following types:

- a. Institutional recognition—laws, standards, government policies, or plans.
- b. Technical recognition—guidelines, scientific or technical knowledge, or judgment of recognized resource persons

- c. Public recognition—social or cultural values or opinion of a segment of the public, especially the stakeholders directly affected by the project
  - d. Professional interpretation of the evaluator
2. Prediction of the magnitude of the potential impacts

This step refers to the description, quantitatively (where possible) or qualitatively, of the anticipated impacts of the proposed project. This may be achieved through the use of models or comparison with other similar activities. The predicted level of impact magnitude may be due to uncertainties in the baseline conditions, the proposed activities, external developments, or the prediction model.

3. Identification of the mitigation measures

If it is determined that the predicted impact is significant when compared with the Criteria for Determining Significance, suitable mitigation measures are identified. There is a range of mitigation measures that can be applied to reduce impacts. Broadly, these measures can be classified into five categories:

- a. Avoiding the impact altogether by not taking a certain proposed activity or parts of an activity, for example, using CFC-free equipment to avoid impact on ozone layer
- b. Minimizing impacts by limiting the degree or magnitude of the activity, for example, minimizing dust emission by reducing vehicle speed
- c. Rectifying the impact by repairing, rehabilitating, or restoring the affected environment
- d. Compensating for the impact by replacing or providing substitute resources or environments.

The project proponent plays a key role in developing the mitigation plan by identifying possible mitigation measures and assessing the feasibility of proposed measures.

4. Evaluation of the residual impact

Incorporation of the suggested mitigation measures reduces the adverse impact of the project and brings it within the acceptable limit. This step refers to the identification of the anticipated remaining impacts after mitigation measures have been applied—the residual impacts.

5. Identification of the monitoring requirements

The last step in the assessment process is the identification of the minimum monitoring requirements. The scope and frequency of the monitoring depends on the residual impacts. The purpose of monitoring is to confirm that the impact is within the predicted limits and to provide timely information if unacceptable impact is taking place.

### 7.3 Impacts Associated with Construction Activities

The environmental impacts associated with the construction activities of the new plants and the import pipeline are discussed in this section. The followings are the overall potential issues related to the proposed project:

- ▶ Construction Noise
- ▶ Dust Emission
- ▶ Vehicle and Equipment Exhaust
- ▶ Soil Erosion
- ▶ Soil Contamination

A construction phase environmental management plan is prepared and is included as **Appendix D**.

#### 7.3.1 Construction Noise

Depending on the construction equipment used and its distance, the receptors may typically be exposed to intermittent and variable noise levels. During the day such noise results in general annoyance and can interfere with sleep during the night. In general, human sound perception is such that a change in sound level of 3 dB is just noticeable, a change of 5 dB is clearly noticeable, and a change of 10 dB is perceived as a doubling or halving of sound level.

#### **Potential Issues**

There are several settlements within 4 km of the plant area. The environmental issue related to construction noise is the potential disturbance from the construction activities and traffic as a result of the proposed project. The only settlement at risk due to the construction noise is the MGCL colony which is adjacent to the southern boundary of the ECPL property limit.

#### **Existing Conditions**

The exiting significant sources of noise in the project area include the highway traffic, railway traffic, and the ECPL existing plant. The result of a noise survey in the area is presented in **Appendix E**.

#### **Criteria for Determining Significance**

Since the project is not located in a declared industrial zone, the World Bank guidelines for noise (**Exhibit 7.1**) require that the sound level in the residential areas should not exceed 55 dB(A) during day time and 45 dB(A) during the night.<sup>1</sup> An alternate criterion is the World Health Organization (WHO) guidelines.<sup>2</sup> The WHO guidelines

---

<sup>1</sup> World Bank, UNIDO and UNEP. 1999. *Pollution Prevention and Abatement Handbook 1998, Towards Cleaner Production*. Environment Department, The World Bank; UNIDO; UNEP.

<sup>2</sup> World Health Organization. 1999. *Guidelines for Community Noise*.

(**Exhibit 7.2**), in addition to specifying the energy-average sound level  $L_{eq}$ , also prescribe the maximum noise level  $L_{max}$ . The maximum noise level is important when there are distinct events to the noise.

### **Impact Analysis**

The construction activities will result in civil works and construction traffic near the MGCL residential colony, despite the fact that the civil works will be carried out approximately 200-250 m north of the MGCL colony, equipment laydown areas, construction materials storage area, etc will be within 100 m of the MGCL colony, with the exception of the section of the MGCL property that is across the road and bordered on three sides by the ECPL property where civil work carried out will be less than 100 m away. The noise levels will depend on the equipment used, the period of exposure and the distance from the source.

A rigorous prediction of noise due to construction activity at given location at a given time requires details such as, maximum and minimum noise levels, variation of noise during a work cycle, and distance from receptor, for each piece of equipment. However, a rigorous approach is more appropriate for analysis of noise from large construction sites where at a given time several pieces of equipment are in operation. Further, the construction activity at a given location is also short. For this reason, a brief analysis is undertaken as shown in **Exhibit 7.3**. For each piece of equipment the following information is provided:

- Column 1: The list of all equipment that is typically used on a construction site.
- Column 2: The peak noise level range of the construction equipment at a reference distance of 15.2 m (50 ft) from the source.
- Column 3: The typical peak noise level in a typical work cycle.
- Column 4: The 'quieted' noise level. This is the noise level that is easily achieved by proper maintenance of equipment and use of simple noise reducing features such as enclosures and mufflers.
- Column 5: The noise level of the equipment is not constant but depends on its operation and usage, so it varies with time. The expected noise level,  $L_{eq(8-hr)}$ , for an 8-hour shift due to a single piece of equipment at a receptor 150 m (the approximate distance from the center of the construction corridor to the nearest commercial centre) from the source taking into account the variations in sound level in a typical cycle. This is under no-mitigation conditions and assuming no attenuation.

When more than one pieces of equipment are working simultaneously, the noise level at the receptor will increase. The predicted noise levels when three of the noisiest equipment are operating will be about 64 dB(A). This assumes no attenuation or mitigation. The attenuation due to topographic factors could be between 3 and 5 dB(A). Furthermore, the boundary wall of the MGCL colony is going to result in further attenuation of noise. The ambient noise levels (due to existing plant operation) observed along the road separating the ECPL property line and the MGCL colony were between

36 dB(A) to 55 dB(A). The noise levels observed on the boundary of the MGCL workshop area (the area that is across the road) is about 50-55 dB(A).

### **Mitigation**

The following mitigation measures are suggested:

1. Noise Survey

Noise survey of all construction equipment will be conducted prior to their deployment. For this purpose each piece will be tagged and the following data will be recorded:

- a. Survey date, surveyor, and noise meter ID
- b. Equipment ID, type, and make
- c. Noise levels at reference distance(s) in idling conditions, in all four directions
- d. Noise levels at reference distance(s) in full throttle conditions, in all four directions

The survey will be repeated periodically.

2. Reduce equipment noise at source: Based on the above survey, equipment emitting excessive noise in comparison with other similar equipment will not be allowed to operate. Equipment under use will be regularly maintained, tuned, and provided with mufflers to minimize noise levels. Equipment in poor state of maintenance, particularly without effective noise control will be checked to determine if it can be improved, and replaced with less noisy equipment as soon as practicable.
3. Construction of noise wall along the Southern boundary of the ECPL property to provide additional abatement of noise at the MGCL colony.
4. Blowing of horns will be prohibited for all construction vehicles
5. Stationary noise sources will be kept as far away from the colony as practical
6. Construction traffic will be kept to a minimum during night-time
7. All high noise activities will be scheduled during the day

### **Residual Impacts**

No irreversible noise impact is expected from the construction activities of the proposed project. It is possible that occasionally there will be exceedances of the significance criteria during construction. This may happen if, for example, a number of construction machineries are deployed close to the commercial areas. This will cause a nuisance for a short period.

### **Monitoring Requirements**

Given the residual impacts, periodic monitoring of noise at source, at the construction site, and at the receptors level will be undertaken.

### 7.3.2 Dust Emission

Dust emission from construction sites is a concern particularly if the site is near residential areas. Dust or the equivalent technical term ‘particulate matter’, is generally defined as any airborne finely divided solid or liquid material up to the size of about 100 microns (micrometers or one-millionth of a meter). The main health hazards are the particles smaller than 10 microns (designated as ‘PM<sub>10</sub>’) as they are respirable. Larger particles also tend to settle rapidly and often do not reach receptors. In cases where they reach the receptors, the dust is considered a nuisance as it may soil property and affect visibility.

#### **Potential Issues**

The MGCL colony is potentially susceptible to dust emissions as a result of the proposed construction activities at the plant site. The pipeline RoW does not cross through any communities. It is crossing mainly through agricultural fields and along the national highway. It is not expected that there will be any impacts due to dust emissions from construction activities along the pipeline RoW.

#### **Existing Conditions**

The existing ambient air quality has been discussed in detail in **Section 4**.

#### **Criteria for Determining Significance**

For the construction activity at the plant site and the gas import pipeline RoW, a significant effect on the environment will be interpreted if there is an increase in visible dust beyond the limits of the ECPL property boundary and the construction RoW.

#### **Impact Analysis**

Potential sources of particulate matter emission during construction activities include earthworks (preparation of Row, dirt or debris pushing and grading), exposed surfaces, exposed storage piles, truck dumping, hauling, vehicle movement on unpaved land, combustion of liquid fuel in equipment and vehicles.

The quantity of dust that will be generated on a particular day will depend on the magnitude and nature of activity and the atmospheric conditions prevailing on the day. Due to the uncertainty in values of these parameters, it is not possible to calculate the quantity from a ‘bottom-up’ approach, that is, from adding PM<sub>10</sub> emissions from every activity on each construction site separately.

A wide variety of options exist to control emissions from construction sites. The most effective means of reducing the dust emission is wet suppression. Watering exposed surfaces and soil with adequate frequency to keep soil moist at all times can reduce the total dust emission from the project by as much as 75%.<sup>3</sup> Specific measures that can be employed for the proposed construction are discussed in the following section.

---

<sup>3</sup> El Dorado County Air Pollution Control District. 2002. Guide to Air Quality Assessment: Determining Significance of Air Quality Impacts Under the California Environmental Quality Act. First Edition. <<http://co.el-dorado.ca.us/emd/apcd>>

Emissions during the import pipeline construction will be associated with land clearing, ground excavation, filling, and restoration operations. Dust emissions are likely to vary substantially from day to day, depending on the level of activity, the specific operations, and the prevailing meteorological conditions. Soil piles can also be a source of dust due to wind and passage of traffic near the piles. The impact of the emission may also vary depending on the distance of the receptor. Mitigation measures are proposed to minimize the impact of dust emission.

### **Mitigation**

The following mitigation measures will be implemented at the each construction site during construction to control emission of particulate matter:

1. Water will be sprinkled daily or when there is an obvious dust problem on all exposed surfaces to suppress emission of dust. Frequency of sprinkling will be kept such that the dust remains under control, particularly when wind is blowing towards the receptors.
2. Dust emission from soil piles and aggregate storage stockpiles will be reduced by appropriate measures. These may include:
  - a. Keeping the material moist by sprinkling of water at appropriate frequency
  - b. Erecting windshield walls on three sides of the piles such that the walls project 0.5 m above the pile, or
  - c. Covering the pile, for example with tarpaulin or thick plastic sheets, to prevent emission.

### **Residual Impacts**

The dust emission during construction activities may temporarily affect the ambient air quality, however, within the acceptable limits. The effects of the dust nuisance are temporary with no lasting impact expected after the completion of the construction.

### **Monitoring Requirements**

In view of the residual impacts, the following monitoring measures will be undertaken:

- ▶ Ambient air concentration of the PM<sub>10</sub> will be periodically monitored in the areas around the plants.
- ▶ Dust emission from the construction activity will be visually monitored, particularly when activity is undertaken close to the receptors, to prevent visible dust beyond the plant property lines.

## **7.3.3 Vehicle and Equipment Exhaust**

### **Potential Issues**

Combustion exhaust from vehicles and construction can affect the ambient air quality of the project area.

### ***Existing Conditions***

The existing ambient air quality has been discussed in detail in **Section 4**.

### ***Criteria for Determining Significance***

A significant impact on ambient air quality will be interpreted if the vehicles or equipment emit visible smoke.

### ***Impact Analysis***

Combustion processes in generators and other construction equipment result in exhaust gases that can effects the ambient air quality locally. However, the environmental issue can be avoided by using properly maintained equipment.

### ***Mitigation***

The following mitigation measures will be incorporated to prevent any adverse impact on the ambient air quality:

1. All vehicles, generators and other equipment used during the construction will be properly tuned and maintained in good working condition in order to minimize emission of pollutants
2. The stack height of the generators will be at least 3 m above the ground

### ***Residual Impacts***

Implementation of the proposed mitigation measures is likely to leave no long-term residual impact on the ambient air.

### ***Monitoring Requirements***

To ensure compliance regular inspection of equipment and vehicles will be undertaken.

## **7.3.4 Soil erosion**

### ***Potential Issues***

There are no issues of soil erosion as a result of construction of plants. Erosion of soil can occur along the RoW due to wind or storm water run-off.

### ***Existing Conditions***

The proposed pipeline route passes along the national highway and agricultural fields. Generally the land in the area is flat with very little change in the gradient.

### ***Criteria for Determining Significance***

A significant impact on soil stability will be interpreted if after completion of the construction activities the construction corridor is left with unsealed surfaces or surfaces devoid of vegetation and without compaction. Secondly, the land is not graded to its natural or pre-project condition and drainage.

### **Impact Analysis**

Pipeline construction will include activities such as, leveling, and trenching that will result in loosening up of soil making the surface prone to erosion from wind and water. Erosion control measures are part of good engineering practice that if employed will prevent any erosion-related problems in future. Required mitigation measures are presented in the next section.

### **Mitigation**

Following measures will be employed to minimize soil erosion:

1. The corridor that is disturbed during pipeline construction will be kept to a minimum.
2. The construction corridor along the pipeline's RoW will be properly marked
3. The movement of machinery will be restricted to the construction corridor
4. Excavated material will be placed within the pipeline work corridor
5. The topsoil along the trench will be stockpiled separately, and will be used as the upper most soil layer during the back filling of the trench
6. The backfill will be crowned to a height of about 200 mm above the adjacent ground surface to allow for settling
7. Soil erosion control measures (e.g. silt fences, rip rap) will be undertaken where necessary during construction
8. The RoW, campsites and other construction sites will be restored as close as possible to their pre-project conditions after the installation of the pipeline is completed. For this purpose a Reinstatement Plan will be prepared that may include the following:
  - a. Removal of debris, excess construction material, cable, machinery parts or timber
  - b. Disposal of surplus soil
  - c. Repair to damaged or blocked drainage
  - d. Filling of all ditches and pits
  - e. Soil erosion control measures where necessary
  - f. Grading of the RoW to restore the natural contour of the ground and allow natural surface drainage

### **Residual Impacts**

Implementation of the proposed mitigation measures is likely to leave insignificant residual impact on the soil stability of the project area. To ensure this, the pipeline RoW will be regularly inspected after the completion of construction work.

### **Monitoring Requirements**

The monitoring measures will include:

- ▶ Post-reinstatement record of the condition of the RoW
- ▶ Inspection for signs or erosion during and after the construction

### **7.3.5 Soil Contamination**

#### **Potential Issues**

Spills during refueling, discharges during vehicle and equipment maintenance, traffic accidents and leakages from equipment and vehicles often result in contamination of soil and potentially that of surface water bodies at the construction site.

#### **Existing Conditions**

The existing sources of soil contamination in the area include the industrial units, domestic activities, and vehicles and maintenance.

#### **Criteria for Determining Significance**

A significant impact on soil will be interpreted if visible amount of hydrocarbon is observed in soil. Similarly discharge of effluents to the environment that is not meeting the NEQS and the World Bank/IFC guidelines value will also be considered as an adverse effect.

#### **Impact Analysis**

During a typical construction project spill of fuel, lubricants, and chemicals takes place:

- ▶ During transfer from one container to another or during refueling
- ▶ During maintenance of equipment and vehicles
- ▶ Due to leakages from equipment and containers, and
- ▶ As a result of traffic accidents.

Depending on the nature of the material, location of spill and quantity of spill, soil can get contaminated.

#### **Mitigation**

The following control measures are proposed to mitigate the impact on soil resources:

1. Spill prevention trays will be provided and used at refueling locations
2. On-site maintenance of construction vehicles and equipment will be avoided as far as possible. In case on-site maintenance is unavoidable, tarpaulin or other impermeable material will be spread on the ground to prevent contamination of soil.
3. Regular inspections will be carried out to detect leakages in construction vehicles and equipment.

4. All vehicles will be washed in external commercial facilities or at dedicated facilities where the contaminated water is not released into the soil.
5. Fuels, lubricants, and chemicals will be stored in covered bounded areas, underlain with impervious lining.
6. Appropriate arrangements, including shovels, plastic bags and absorbent materials, will be available near fuel and oil storage areas.
7. Contaminated soil will be removed from the site and taken to the incineration.
8. Emergency plan for spill management will be prepared and inducted to the staff for any incident of spill.

Implementation of the proposed mitigation measures is not likely to leave any long-term residual impact on the soil, however, insignificant amount of hydrocarbon may be left in the soil due to minor spills where remedial measures are not possible.

### **Residual Impacts**

No long term residual impacts are expected if the above listed measures implemented.

### **Monitoring Requirements**

To ensure compliance:

- ▶ Regular inspection of the soil of the area of the construction activities will be undertaken.
- ▶ Incident record of all moderate and major spills will be maintained. The record will include the location of spill; estimated quantity; spill material; restoration measures; photographs; description of any damage to vegetation, water resource, or community asset; and corrective measures taken.

## **7.4 Impacts Associated with Plant Operations**

The environmental impacts associated with the operational phase of the expanded plants and the Natural Gas import pipeline is discussed in this section. The impacts that are discussed are the following:

- ▶ Plant Noise
- ▶ Emissions
- ▶ Effluents
- ▶ Accidental Releases
- ▶ Solid Waste Management
- ▶ Cultural Resources

### 7.4.1 Plant Noise

#### **Potential Issues**

The plant noise will increase after installation of new facilities and may result in disturbance to the receptors.

#### **Existing Conditions**

The sources of noise in the project area are discussed in **Section 4**. The ambient noise data in project area is provided in **Exhibit 7.1**.

#### **Criteria for Determining Significance**

The World Bank guidelines for noise (**Exhibit 7.2**) require that the sound level in industrial and commercial areas should not exceed 70 dB(A).<sup>4</sup> An alternate criterion is the World Health Organization (WHO) guidelines.<sup>5</sup> The WHO guidelines (**Exhibit 7.3**), in addition to specifying the energy-average sound level  $L_{eq}$ , also prescribe the maximum noise level  $L_{max}$ . The maximum noise level is important when there are distinct events to the noise. However, since the proposed project site is not located in a designated industrial area ECPL will have to ensure that the noise levels at the receptors does not exceed 55 dB(A) during day-time and 45 dB(A) during night-time.

#### **Impact Analysis and Mitigation**

The ambient noise modeling was conducted in order to predict the noise levels at sensitive receptors such as any human settlements in the surrounding areas of the plant and assess whether the IFC guidelines would be met. In this case the sensitive receptors were the MGCL colony and the Jung village.

A baseline noise study was conducted by gathering data at different points both inside and outside the plant. This was followed by an analysis of the predicted noise levels from the proposed project. Lastly, the cumulative effect of the present noise scenario coupled with the proposed project was analyzed to obtain the predicted noise levels at the chosen sensitive receptor locations.

The noise level measurements were carried out at 91 different locations, both inside and outside the plant boundaries during both day and night times. Contours were developed to assess the baseline noise emission from the existing plant. Attenuation due to the MGCL colony wall was calculated. Noise ratings of the various noise sources of the expansion plant were used to estimate the noise that would be emitted due to the expansion plant and finally the cumulative noise at the receptors was estimated for the combined operation of the existing and proposed plants. The noise modeling revealed that the day time noise levels as a result of the combined operation would meet the World Bank guidelines (see **Exhibit 7.1**) at the MGCL colony boundary and at most places near the Jung village boundary, however, the night time noise was found to exceed the target

---

<sup>4</sup> World Bank, UNIDO and UNEP. 1997. *Pollution Prevention and Abatement Handbook, Towards Cleaner Production*. Environment Department, The World Bank; UNIDO; UNEP.

<sup>5</sup> World Health Organization. 1999. *Guidelines for Community Noise*.

standards. These results are fairly conservative and the actual noise levels at the receptors should be lower due to two main factors; the additional attenuation that would occur due to the second plant boundary wall and the error caused in developing the noise contours and working out the attenuation. The error is a result of the reflection of noise from the boundary wall that is occurring and will occur for the proposed plant as well, as the noise level within the plant boundary rises due to the reflected sound thereby raising the noise potential of each contour and presenting a higher value of the resultant noise at the receptor. Details of the noise modeling carried are presented as **Appendix E**.

The noise values calculated are being shared with the equipment suppliers and they have been given the target of ensuring that the noise emitted from the plant is in compliance with the World Bank guidelines. ECPL intends to use noise mitigation measures such as the noise abatement walls to ensure that the noise levels at the receptors are within the World Bank guidelines. The density of the noise wall will be at least 100 kg/m<sup>2</sup> which would be sufficient to ensure compliance with the required standards.

A noise survey along the boundaries of the MGCL colony and the Jhung village will be carried out once the project is commissioned to ensure compliance with the target standards during the operational phase of the project.

### ***Residual Impacts***

The noise from the plant is expected to be within the allowable World Bank limits once the mitigations and control measures are in place and therefore is not expected to have any residual impacts.

### ***Monitoring Requirements***

Periodic monitoring of noise along the adjacent communities ie the MGCL colony and the Jhung village will be carried out to ensure that the World Bank noise guidelines are met.

## **7.4.2 Emissions**

### ***Existing conditions***

The existing air quality has been discussed in detail in **Section 4**.

### ***Potential Issues***

The increased emission from the plant can potentially affect the ambient air quality.

### ***Significance Criteria***

A significant impact will be interpreted if the concentration of pollutants in the ambient air or the plant emissions exceeds the NEQS and the IFC guidelines values.

### ***Impact Analysis***

The main sources of gaseous emissions are the flares and stacks of the existing and proposed urea and ammonia plants.

To assess the impact on the ambient air quality, the increase in concentration of the pollutants described above due to each individual stack was assessed using the ISC 3 air dispersion model. The results of the air dispersion modeling are given in **Exhibits 7.4** and **7.5**. The results indicate that the ground level concentrations and emissions of all the pollutants are well below the limits provided by the NEQS and World Bank guidelines. Details of the air dispersion modeling are presented as **Appendix F**.

#### ***Mitigation Measures***

No specific mitigation measures are proposed for general gaseous emission as the emission is within the target standards set by the NEQS and World Bank guidelines.

#### ***Residual Impacts***

The concentration of pollutants will increase as shown in **Exhibit 7.5**, however, the increase will be well within the limits.

#### ***Monitoring Plan***

The ambient air quality will be periodically monitored in the vicinity of the plant to ensure that the concentration levels of the gases are within the permissible limits.

### **7.4.3 Effluents**

#### ***Potential Issues***

The discharge of increased and untreated sewerage can impact on soil, water resources, and biodiversity of the project area and can also become a safety hazard for the surrounding communities.

#### ***Existing Conditions***

Effluent from the existing plant and utilities is treated in the existing treatment plant to meet the NEQS and IFC guideline values. The treated effluent at discharge level is monitored and tested daily to ensure its compliance with requirements.

#### ***Criteria for Determining Significance***

A significant impact will be interpreted if effluent containing pollutants in concentration exceeding the NEQS and IFC guideline values are discharged to the environment.

#### ***Impact Analysis and Mitigations***

The liquid effluent from the existing plant facilities is approximately 0.6 million gallons per day (mgd). The proposed expansion plant will add approximately 0.014 mgd to the existing effluent. Most of the effluent generated at the plant including the proposed plant will be NEQS/IFC compliant and will be released into the ECPL evaporation ponds.

Non-NEQS/IFC compliant effluent will be separated and released into the lined ponds. This arrangement is also being extended for the expansion plant effluent.

### ***Residual Impacts***

As only treated water, meeting the NEQS and IFC guideline values, will be discharged to the environment no significant impact on surface and groundwater is expected.

### ***Monitoring Requirements***

Periodic monitoring will include:

- ▶ Discharge rate of overall wastewater
- ▶ Chemical analysis of different wastewater streams

## **7.4.4 Accidental Release of Ammonia**

### ***Potential Issues***

Project operations will involve use of Ammonia in large quantities which has the potential to harm human health and the environment around it if released accidentally into the atmosphere.

### ***Criteria for Determining Significance***

The exposure limits for Ammonia is shown in **Exhibit 7.6**. A significant impact will be interpreted if the receptors are exposed to ammonia concentrations that are injurious to health.

### ***Impact Analysis***

Assessment of risk associated with hazardous material generally follows these steps:

Step 1: Identifying the hazardous conditions and the associated hazardous event

Step 2: Assessing the consequences of the hazardous event

Step 3: Assessing the likelihood of the hazardous event

Combination of the likelihood and consequences of a specified hazardous event occurring is referred to as risk.

### ***Identification of Hazard***

Eight separate cases were identified of possible ammonia release events. Three cases are from the ammonia reservoir of the proposed plant and five are from leakages in vessels and tanks from the proposed plant.

### ***Assessing the Consequences***

To assess the dispersion of accidental releases of ammonia due rupture in the storage tank or the pipeline the United States Air Force's accidental release model AFTOX is used. The model simulates the atmospheric dispersion of lighter-than-air gases. The types of releases treated by the model include a ground-level evaporating pool, an elevated horizontal jet, a stack or elevated vertical jet, and an instantaneous volume source..

The model input parameters are as described in **Exhibit 7.7**. Each emission scenario is simulated for four typical climatic conditions (two daytime and two nighttime) and two

averaging time corresponding to the short-term (15-minutes) and long-term (8-hours) exposure limits.

The model results are presented from the viewpoint of an observer or receptor located downwind of the source. From the vantage point, the observer sees the maximum cloud concentration at certain specific time after the release and is exposed to the cloud for the specific time period.

The results of the dispersion modeling are presented in **Exhibit 7.8**, the distance from the point of release, along the downwind direction, at which the concentration exceeds a specific limit is given. Details of the air dispersion modeling are presented as **Appendix G**.

#### *Frequency of Accident*

Based on the US statistics, the frequency of industrial accidents related to the three gases is shown in **Exhibit 7.9**.

#### *Assessment of Risk*

The consequence of an accidental release may include fatalities in case of severe short term exposure, and various diseases such as disruption of the endocrine system, neurotoxicity, and immune system suppression.

#### **Mitigation**

An emergency response plan has been prepared for the existing plant to avoid accidental release of ammonia and to minimize the impacts. The Community Awareness and Emergency Response (CAER) program has been initiated to involve all surrounding communities in the response. A similar response plan will be extended for the proposed expansion.

The key features of the emergency response plan include the following.

1. Identification of hazardous chemicals, processes and the operations
2. Release scenarios, consequences in term of heat generation, over pressure and toxic release etc.
3. Preparation of site plan for damage control
4. Identification of the vulnerable zones
5. Classification of unit or units which have the most potential for creating on-site as well as off-site emergency
6. Identification of the important facilities available in the vulnerable zone
7. Identification of the requirements of various departments in-site as well as out-site the process plant for coping emergency situation
8. Emergency drills are being conducted to ensure readiness of emergency squad and community

In order to improve the inherent safety of the site and surrounding communities, ECPL intends to decommission its existing 1,200 metric ton (MeT) pressurized refrigerated

ammonia storage tank and replace it with a new 5,000 MeT capacity double-walled atmospheric tank. This tank is the safest ammonia storage design with the following key features:

1. Double walls
2. Storage at atmospheric pressure
3. Pumps with double mechanical seals
4. All vents and PSVs connected to flares
5. Refrigeration system

Another safety feature employed by ECPL is its site operating strategy that has been in effect for the past twenty years of maintaining minimum inventory. At the moment ECPL does not store more than 300 MeT of ammonia. After the proposed expansion the policy will be continued and a minimum inventory of ammonia will be maintained at the site.

### ***Monitoring Requirements***

The monitoring will involve:

- ▶ Bolts, nuts and studs, other pipe connections of proper material specification strictly be used where there is chance of leakage.
- ▶ A proper system of periodic inspection of all plants and equipment including cocks, valves and pipelines and degassing system should be introduced and followed jointly by the process and maintenance department. Preventive maintenance should be planned in a manner to synchronize gradually with periodic routine shut down of equipment and plant.
- ▶ A complete register for recording the periodic testing should be maintained.
- ▶ A control room equipped with the instruments for automatic detection of small amount of gas releases and their location.
- ▶ Process flow, temperature, instrumentation control, pressure relief, safety and general operating condition should be examined to ensure that the plant would not only operate safely but should also fail safely if it is going to fail at all.
- ▶ Periodic safety audit by both internal and external audit team should be undertaken by the management.

### **7.4.5 Solid Waste Management**

#### ***Potential Issues***

The increased waste generated due to the proposed expansion can potentially affect the environment.

#### ***Existing Conditions***

ECPL regularly monitors solid waste generated in the existing plant.

### **Criteria for Determining Significance**

As no regulations for waste handling and disposal exists, an adverse impact on the environment will be interpreted if,

- ▶ Any person is exposed to potentially hazardous waste generated by the project
- ▶ Project generates waste that can be avoided through practicable means (waste minimization)
- ▶ Reusable waste generated by the project is discarded
- ▶ Recyclable waste instead of separation at the source is dumped at the trash bins
- ▶ Any waste generated by the project is scattered at any place outside the designated bins, or
- ▶ Non-recyclable and non-reusable waste ends up at any place other than the designated landfill site.

### **Impact Analysis**

In the absence of national or domestic regulations and a waste management system in the project area, waste disposal can potentially become a serious environmental issue. To avoid any potential issue, the ECPL's project management has imposed internal controls for the existing plants. These measures will be continued in the proposed expansion plan.

The main sources of solid waste produced are the sludges from the canal water and cooling tower basin. Other sources of solid waste include activated carbon, catalyst, oily rags, and office waste. The total solid waste generation of the combined operation of the existing and proposed plants would be approximately 7,127 tons per year.

ECPL has developed a comprehensive plan for solid waste management and the same shall be applicable for proposed project.

### **Mitigation**

In addition to above mentioned assessment and project design measures to minimize the waste, and handling options, following general management level mitigation measures will be taken:

1. On-site handling
  - a. Recyclable material will be separated at source. Separate bins will be placed at the each site for different type of materials—plastic, paper, metal, glass, wood, and cotton etc. The recyclable waste will be delivered to approved waste contractors.
  - b. All hazardous waste will be separated from other wastes.
  - c. Hazardous waste that cannot be disposed of through acceptable means will be stored in an on-site storage facility until an isolated off-site hazardous waste disposal facility is available.
2. Audits
  - a. On-site audits of the waste management will be undertaken on a regular basis.

- b. Audits of the waste disposal contractors and waste disposal facilities will be undertaken on a regular basis to check that procedures are being followed.
3. Records
- a. Records of all waste generated will be maintained. Quantities of waste disposed, recycled, or reused will be logged on a Waste Tracking Register.
4. Disposal
- a. All non-hazardous waste material that cannot be recycled or reused will be transferred to approved landfill sites in Karachi.
  - b. Depending on the nature and quantity of the hazardous waste, it will either be disposed of by licensed hazardous waste contractors, or will be incinerated at the proposed incinerator that is being installed.
  - c. The possibility of returning the packaging to the manufacturers for reuse will be explored.
  - d. Recyclable waste will be disposed of via approved waste contractors.
  - e. Chemical containers (including partially full containers) will be returned to vendors.
5. Other management measures
- a. An emergency response plan will be developed for the hazardous waste (and substances).
  - b. Training will be provided to personnel for identification, segregation, and management of waste.
  - c. All containers of hazardous waste will be appropriately labeled.
  - d. Equipment and material containing asbestos, poly-chlorinated biphenyls (PCBs), and ozone depleting substances (ODSs) will not be used.

A Hazardous Materials Management Plan will be prepared that contains the following management and mitigation measures:

1. Storage and handling of hazardous materials will be in accordance with international standards and appropriate to their hazard characteristics. Storage and liquid impoundment areas for fuels and hazardous process chemicals will be designed with secondary containment to prevent spills and contamination of soil and groundwater. The secondary containment will be impervious with a capacity of at least 110% of the largest single container.
2. Labeling will be placed on all storage vessels as appropriate to national and international standards. The labeling will clearly identify the stored materials.
3. Supporting information such as MSDS will be available for all hazardous materials.
4. A Hazardous Materials Register will be in place that covers:
  - a. Hazardous Material name

- b. HAZCHEM/United Nations Code
- c. MSDS
- d. Summary of maximum inventory
- e. Storage requirements and precautions
- f. Location, physical properties of the materials where they are used
- g. Approved disposal methods

### ***Residual Impacts***

Even after implementation of the above measures, it is possible that some littering may take place. Monitoring and inspections will be undertaken to minimize the residual impact.

### ***Monitoring Requirements***

The monitoring measures will include:

Records of all waste generated during the construction period will be maintained. Quantities of waste disposed, recycled, or reused will be logged on a Waste Tracking Register.

On-site audits of the waste management will be undertaken on a regular basis.

Audits of the waste disposal contractors and waste disposal facilities will be undertaken on a regular basis to check that procedures are being followed.

## **7.4.6 Cultural Resources**

### ***Impact Analysis***

Although there are no protected cultural resources within the identified project area, the temple of 'Sant Sathra' (a Hindu saint) is located about 2.5 km from the plant site.

Project activities and traffic during operations will have no interference with the temple because the access route for the temple will not be used for the plant access.

### ***Mitigation Measures***

No specific mitigation measures are needed.

## **7.4.7 Carbon Emission Reductions**

The technology options adopted by ECPL for the proposed project have provided them the opportunity to explore two avenues of carbon emission reductions. Pakistan has ratified the Kyoto protocol and is therefore entitled to payment of carbon credits from countries with carbon emission targets under the Clean Development Mechanism (CDM).

The two ways in which the proposed project will result in reduced carbon emissions are:

- ▶ Use of purge gas in gas turbines: The purge gas from the processes will be used to drive the gas turbines used to generate power for the ECPL plant. This will result in lowering the fuel usage of the gas turbines.
- ▶ Removal of CO<sub>2</sub> from the natural gas: ECPL intends to remove CO<sub>2</sub> from the natural gas being supplied to the plant and utilize it for its urea production. This will decrease the carbon emission of the plant as the removed gas would have otherwise been released into the atmosphere along with the exhaust emissions.

## **7.5 Environmental Impact of Plants Decommissioning**

At the end of the useful life of the plants decommissioning of the plant may take place. Alternatively, the plants may be rehabilitated for continued service. It is too early to predict the course of action. The decommissioning may involve:

- ▶ Demolition of structure
- ▶ Scraping of metal
- ▶ Disposal of debris
- ▶ Removal of tanks
- ▶ Decontamination of piping and equipment

All wastes will be removed from the site. The site will be contoured to allow surface water flow without erosion.

Issues such as future use of the site and its infrastructure will also be an aspect. Some of the buildings may put to community use.

At this stage, it is not possible to discuss these aspects in detail. A decommissioning plan will be prepared prior to closure and submitted to regulatory authorities as required.

**Exhibit 7.1: World Bank Recommended Noise Levels**

<i>Specific Environment</i>	<i>Maximum Allowable Log Equivalent (Hourly Measurements), in dB(A)</i>	
	<i>Day (7:00-22:00)</i>	<i>Night (22:00-7:00)</i>
Residential, institutional, educational	55	45
Industrial, commercial	70	70

**Exhibit 7.2: WHO Guideline Values for Community Noise in Specific Environments**

<i>Specific Environment</i>	<i>LA<sub>eq</sub> (dB)</i>	<i>Averaging Time (hours)</i>	<i>LA<sub>max, Fast</sub> (dB)</i>
Outdoor living area	55	16	–
Dwelling (indoors)	35	16	
School classrooms (indoors)	35	During class	
Hospital, ward rooms, nighttime (indoors)	30	8	40
Industrial, commercial, shopping and traffic areas (indoors and outdoors)	70	24	110

**Exhibit 7.3: Construction Equipment Noise Ranges (dB(A))**

<i>Equipment</i>	<i>Peak Noise Range at 15.2 m</i>	<i>Typical Peak Sound Level in a Work Cycle<sup>a</sup></i>	<i>Typical 'Quieted Equipment' Sound Level<sup>b</sup></i>	<i>Equivalent Noise Level in an 8-hr Shift at Receptor 150 m from Source</i>
Batching plant	82-86	84	81	62.9
Concrete mixers	76-86	85	82	63.9
Cranes	70-94	83	80	54.5
Excavators	74-92	85	82	59.5
Tractors and trolleys	77-94	88	85	62.1
Water bowsers	85-93	88	85	62.1
Graders	72-92	85	82	59.5
Bulldozers	65-95	80	75	54.5
Paver	87-89	88	80	62.5
Pumps	68-72	76	75	54.9
Diesel generators	72-82	78	75	58.1
Vibrators	68-82	76	75	50.5
Drilling machines	82-98	90	87	61.5
Compressors	74-84	81	71	58.1
Dumpers	77-96	88	83	59.5
Road rollers	73-77	75	72	49.5

**Sources:** Bolt, Beranek, and Newman, Noise from Construction Equipment and Operations, Building Equipment, and Home Appliances. USEPA, 1971;  
<http://www.waterrights.ca.gov/EIRD/text/Ch11-Noise.pdf>;  
[http://www.lacsd.org/LWRP%202020%20Facilities%20Plan%20DEIR/4\\_6\\_Noise.pdf](http://www.lacsd.org/LWRP%202020%20Facilities%20Plan%20DEIR/4_6_Noise.pdf);  
<http://newyorkbiz.com/DSEIS/CH18Construction.pdf>

**Notes:** a. Where typical value is not cited in literature, mean of the peak noise range is assumed  
b. Quieted equipment can be designed with enclosures, mufflers, or other noise-reducing features. Where data is not available, a 3 dB reduction is assumed.

**Exhibit 7.4:** Results of Air Dispersion Modeling

<i>Parameter</i>	<i>Source</i>	<i>Target Standard</i>	<i>Estimated Plant Emission</i>
Nitrogen oxides	WB	300 mg/Nm <sup>3</sup>	250 mg/Nm <sup>3</sup>
Ammonia	WB	50 mg/Nm <sup>3</sup>	(no continuous emission)
Urea	WB	50 mg/Nm <sup>3</sup>	(no continuous emission)
Sulfur oxides	NEQS	1,700 mg/Nm <sup>3</sup>	50 mg/Nm <sup>3</sup>
Particulate Matter	WB	50 mg/Nm <sup>3</sup>	

**Exhibit 7.5:** Increase in Ambient Concentration

<i>Pollutant</i>	<i>Pollutant Concentration<sup>a</sup> (<math>\mu\text{g}/\text{m}^3</math>)</i>		
	<i>1 hr</i>	<i>24 hr</i>	<i>Annual</i>
<b>Natural Gas</b>			
Sulfur dioxide	<b>Increase in concentration</b>	<b>21</b>	<b>6</b>
	Guidelines	150	80
Nitrogen oxides	<b>Increase in concentration</b>		<b>46</b>
	Guidelines		100
Carbon Monoxide	<b>Increase in concentration</b>	<b>199</b>	
	Guidelines	40,000	
Particulate Matter	<b>Increase in concentration</b>		
	Guidelines	230	80

**Exhibit 7.6: Ammonia Exposure Threshold Levels<sup>6</sup>**

<i>Exposure by Inhalation</i>		<i>Symptoms</i>
(ppm)	(mg/m <sup>3</sup> )	
34-72	24 - 50	Nose and throat irritation after ten minutes of exposure.
103-192	72 - 134	Irritation of nose and throat after five minutes exposure.
1,002	700	Immediate and severe irritation of respiratory system.
7,160	5,000	Respiratory spasms, rapid suffocation.
Above 14,320	Above 10,000	Pulmonary edema, potentially fatal accumulation of fluid in lungs and death.

**Exhibit 7.7: AFTOX model Input Parameters**

<i>Chemical Properties of Source Material</i>	<i>Ammonia</i>	
Molecular weight	17.03	g/mol
Boiling point temperature	239.8	°C
Heat of Vaporization	1371.2	kJ/kg
Liquid density of source material	682	Kg/m <sup>3</sup>
<b>Field Parameters</b>		
Concentration average time	15	min
Maximum downwind distance	1.5	km
Receptor height	2	m

<sup>6</sup> Official ammonia exposure threshold limits of the Government of Alberta, Canada

**Exhibit 7.8:** AFTOX Results of Accidental Releases of Ammonia

<i>Plant</i>	<i>Case</i>	<i>Distance at which gas comes within desirable limits (m) (below 50 ppm<sup>7</sup>)</i>
Proposed	Ammonia Knock-Out Drum	391
	Ammonia Flash Vessel	538
	Ammonia Flash Vessel (second)	485
	Ammonia Accumulator	563
	Ammonia Receiver	1240
	Ammonia Storage Tank	5,270

**Exhibit 7.9:** Normalized Accident Rates for United States, 1994-1999

<i>Chemical</i>	<i>Accidents/process/year</i>		<i>Accidents/million lbs/year</i>	
	<i>Number</i>	<i>Rank</i>	<i>Number</i>	<i>Rank</i>
Ammonia	0.016	16	0.014	14

<sup>7</sup> The safety limit provided by OSHA

## 8. Conclusion

---

This study was carried out to assess the environmental and socioeconomic impact of the proposed fertilizer expansion project of ECPL in Daharki, Sindh. The assessment was carried out in keeping with the Pakistani legislation, as well as national and international guidelines.

Baseline environmental and socioeconomic information was collected from a variety of sources, including reports of previous studies, published literature, and field surveys. The information collected was used to compose profiles of the natural, socioeconomic, and cultural environments likely to be affected by the project.

The proposed project activities were reviewed, and an assessment made of the potential impact of these activities on the area's natural, socioeconomic, and cultural environments, using both qualitative and quantitative assessment methods as described in **Section 7** of the report. Where appropriate, mitigation measures were recommended to keep the adverse environmental impact within acceptable limits.

As the proposed expansion activities will be carried out within the land already acquired by ECPL, no serious environmental or social impact is envisaged during the construction phase of the project. While in operation, the plant will meet all national emission and effluent standards. The incremental effect of the gaseous emission of the plant on the ambient air quality will be minimal. The only environmental concern of significance are the potential operational noise from the proposed expansion project and the accidental release of ammonia into the atmosphere. Through dispersion modeling it has been demonstrated that no community is likely to get seriously affected even under the worst case emission scenario.

It is therefore concluded that if the field activities, including the implementation of all mitigation measures, are carried out as described in this report, the anticipated impact of the project on the area's natural and socioeconomic environment will be well within acceptable limits. The project will also comply with all the statutory requirements and standards listed in **Section 2** of this report.

To ensure implementation of the mitigation measures an environmental management plan for the construction phase will be prepared separately. ECPL, as part of its core value, is committed to ensuring that the potential impacts of this project both on environment and socioeconomic climate are fully assessed. It has an elaborate Environmental Management System (EMS), certified and regularly audited for ISO-14001:2004. The existing EMS will govern the post-expansion operations as well. A preventive maintenance philosophy, supported by robust inspection plans and sound operational practices will be adopted to ensure sustainable and safe operation of the site.

## 9. References

---

- El Dorado County Air Pollution Control District. 2002. *Guide to Air Quality Assessment: Determining Significance of Air Quality Impacts Under the California Environmental Quality Act*. First Edition. <<http://co.el-dorado.ca.us/emd/apcd>>
- Government of Pakistan. 1986. *Building Code of Pakistan*. Islamabad: Ministry of Housing and Works, Environment and Urban Affairs Division.
- Hafiz Ur Rehman and I. Fehmida. 1997. *A Revised checklist of Reptiles of Pakistan*. Records Zool. Sur. of Pak. Vol. XIII. Zoological Survey Department of Pakistan.
- Hagler Bailly Pakistan. 2007. *Environmental Impact Assessment for the Engro Energy Combined-Cycle Power Plant*.
- IUCN. 2003. *Biodiversity, Status and Management for Creek*. Karachi
- Jaleel S. A. and Khaliluddin M. 1981. *A Check List of Marine Fishes of Pakistan*. Directorate of Marine Fisheries, Karachi, Govt. of Pakistan.
- Minton, S A, Jr. 1966. 'A Contribution to Herpetology of West Pakistan.' Bulletin of American Museum of Natural History 134(2): 27-184.
- Nasir, Y. J. and A.R. Rubina. 1995. *Wild Flowers of Pakistan*. Karachi: Oxford University Press.
- National Engineering Services Pakistan (Pvt) Ltd. Date of Publishing Unknown. *Environmental Impact Studies for Karachi Port Modernisation Project V. Draft Final Report. Volume I*. Karachi.
- Population Census Organization. 1998. District Census Report of Ghotki District. Islamabad
- Quittmeyer, R. C. 1979. *The Seismicity of Pakistan and Its Relation to Surface Faults in Geodynamics of Pakistan*. Quetta: Geological Survey of Pakistan.
- Reagan, J. A. and C. A. Grant. *Highway Construction Noise: Measurement, Prediction, and Mitigation. Special Report*. US. Department of Transportation, Federal Highway Administration. Available from <<http://www.fhwa.dot.gov/environment/noise/highway/index.htm>>
- Roberts, T J. 1997. *Mammals of Pakistan*. Karachi: Oxford University Press.
- Saifullah, S.M.; M. Nizamuddin. 1977. *Studies on the marine algae from Pakistan: Ulvaes*. Botanica Marina, 20: 521-535.
- Shamshad, K.M. 1988. *The Meteorology of Pakistan*. Karachi: Royal Book Company.
- UK DETR. 1999. *Compilation of EU Dioxin Exposure and Health Data: Task 4 - Human Exposure*. Report produced for European Commission DG Environment. United Kingdom Department of the Environment, Transport and the Regions (DETR)

UNEP. 1999. *Dioxin and Furan Inventories, National and Regional Emissions of PCDD/PCDF*. UNEP Chemicals, May 1999.

<http://irptc.unep.ch/pops/pdf/dioxinfuran/difurpt.pdf>

United States Geological Survey. 1998.

<[http://neic.usgs.gov/neis/intensity/pym/mmi\\_abbrev.html](http://neic.usgs.gov/neis/intensity/pym/mmi_abbrev.html)> (March 9, 2004).

World Bank, UNIDO and UNEP. 1997. *Pollution Prevention and Abatement Handbook, Towards Cleaner Production*. Environment Department, The World Bank; UNIDO; UNEP.

World Bank, UNIDO and UNEP. 1999. *Pollution Prevention and Abatement Handbook 1998, Towards Cleaner Production*. Environment Department, The World Bank; UNIDO; UNEP.

World Bank. 1991. *Environmental Assessment Sourcebook, Volume I, Policies, Procedures, and Cross-Sectoral Issues*. World Bank Technical Paper No. 139. Environment Department, The World Bank.

World Bank. 1991. *Environmental Assessment Sourcebook, Volume III, Guidelines for Environmental Assessment of Energy and Industry Projects*. World Bank Technical Paper No. 154. Environment Department, The World Bank.

World Health Organization. 1999. *Guidelines for Community Noise*.

## Appendix A: National Environmental Quality Standards

**Exhibit A.1: NEQS for Municipal and Liquid Industrial Effluents<sup>1,2</sup>**  
(mg/l, unless otherwise defined)

No.	Parameter	Standards		
		Into Inland Waters	Into Sewage Treatment <sup>3</sup>	Into Sea <sup>4</sup>
1.	Temperature increase <sup>5</sup>	≤3°C	≤3°C	≤3°C
2.	pH value	6 to 9	6 to 9	6 to 9
3.	Five-day bio-chemical oxygen demand (BOD) <sub>5</sub> at 20°C <sup>6</sup>	80	250	80 <sup>7</sup>
4.	Chemical oxygen demand (COD)	150	400	400
5.	Total suspended solids (TSS)	200	400	200
6.	Total dissolved solids (TDS)	3,500	3,500	3,500
7.	Grease and oil	10	10	10
8.	Phenolic compounds (as phenol)	0.1	0.3	0.3
9.	Chlorides (as Cl')	1,000	1,000	SC <sup>8</sup>
10.	Fluorides (as F')	10	10	10
11.	Cyanide total (as CN')	1.0	1.0	1.0
12.	Anionic detergents (as MBAS) <sup>9</sup>	20	20	20
13.	Sulphates (SO <sub>4</sub> )	600	1,000	SC <sup>8</sup>
14.	Sulphides (s')	1.0	1.0	1.0
15.	Ammonia (NH <sub>3</sub> )	40	40	40
16.	Pesticides <sup>10</sup>	0.15	0.15	0.15
17.	Cadmium <sup>11</sup>	0.1	0.1	0.1
18.	Chromium (trivalent and hexa valent)	1.0	1.0	1.0
19.	Copper <sup>4</sup>	1.0	1.0	1.0
20.	Lead <sup>4</sup>	0.5	0.5	0.5
21.	Mercury <sup>4</sup>	0.01	0.01	0.01
22.	Selenium <sup>4</sup>	0.5	0.5	0.5
23.	Nickel <sup>4</sup>	1.0	1.0	1.0

Continues ...

... Continued

No.	Parameter	Standards		
		Into Inland Waters	Into Sewage Treatment <sup>3</sup>	Into Sea <sup>4</sup>
24.	Silver <sup>4</sup>	1.0	1.0	1.0
25.	Total toxic metals	2.0	2.0	2.0
26.	Zinc	5.0	5.0	5.0
27.	Arsenic <sup>4</sup>	1.0	1.0	1.0
28.	Barium <sup>4</sup>	1.5	1.5	1.5
29.	Iron	8.0	8.0	8.0
30.	Manganese	1.5	1.5	1.5
31.	Boron <sup>4</sup>	6.0	6.0	6.0
32.	Chlorine	1.0	1.0	1.0

**Explanations:**

1. Dilution of liquid effluents to bring them to the NEQS limiting values is not permissible through fresh water mixing with the effluent before discharging into the environment.
2. The concentration of pollutants in water being used will be subtracted from the effluent for calculating the NEQS limits.
3. Applicable only when and where sewage treatment is operational and BOD = 80 mg/l is achieved by the sewage treatment system.
4. Provided discharge is not at shore and not within 10 miles of mangrove or other important estuaries.
5. The effluent should not result in temperature increase of more than 3°C at the edge of the zone where initial mixing and dilution take place in the receiving body. In case zone is not define, use 100m from the point of discharge
6. Assuming minimum dilution 1:10 discharge, lower ratio would attract progressively stringent standards to be determined by the Federal Environmental Protection Agency. By 1:10 dilution means, for example that for each one cubic meter of treated effluent, the recipient water body should have 10 cubic meter of water for dilution of this effluent.
7. The value for industry is 200 mg/l
8. Discharge concentration at or below sea concentration (SC)
9. Modified Benzene Alkyl Sulphate assuming surfactant as biodegradable.
10. Pesticides include herbicides, fungicides, and insecticides
11. Subject to total toxic metals discharge should not exceed level given at S. No. 25.

**Exhibit A.2: National Environmental Quality Standards for Gaseous Emissions**

No.	Parameter	Source of Emission	Standards
1.	Smoke	Smoke opacity not to exceed	40% or 2 on Ringlemann Scale or equivalent smoke number
2.	Particulate matter <sup>1</sup>	(a) Boilers and furnaces:	
		i) Oil-fired	300
		ii) Coal-fired	500
		iii) Cement kilns	300
		(b) Grinding, crushing, clinker coolers and related processes, metallurgical processes, converters, blast furnaces and cupolas	500
3.	Hydrogen chloride	Any	400
4.	Chlorine	Any	150
5.	Hydrogen fluoride	Any	150
6.	Hydrogen sulphide	Any	10
7.	Sulphur oxides <sup>2,3</sup>	Sulfuric acid/sulphonic acid plants	5,000
		Other plants except power plants operating on oil and coal	1,700
8.	Carbon monoxide	Any	800
9.	Lead	Any	50
10.	Mercury	Any	10
11.	Cadmium	Any	20
12.	Arsenic	Any	20
13.	Copper	Any	50
14.	Antimony	Any	20
15.	Zinc	Any	200
16.	Oxides of nitrogen <sup>3</sup>	Nitric acid manufacturing unit	3,000
		Gas-fired	400
		Oil-fired	600
		Coal-fired	1,200

1. Based on the assumption that the size of the particulate is 10 micron or more.
2. Based on 1 per cent sulphur content in fuel oil. Higher content of sulphur, will cause standards to be pro-rated.
3. In respect of emissions of sulphur dioxide and nitrogen oxides, the power plants operating on oil and coal as fuel shall in addition to National Environmental Quality Standards (NEQS) special above, comply with the following standards.

**Exhibit A.3: Pakistan Standards for Sulfur Dioxide and Nitrogen Oxides  
for Power Plants Operating on Oil and Coal**

**A. Sulfur Dioxide**

Sulfur Dioxide Background Levels (mg/m <sup>3</sup> )			Standards	
			Criterion I	Criterion II
Background Air Quality (SO <sub>2</sub> basis)	Annual Average	Maximum 24- Hour Interval	Max. SO <sub>2</sub> Emissions (TPD)	Max. Allowable 1-Year Average Ground Level Increment to Ambient (mg/m <sup>3</sup> )
Unpolluted	<50	<200	500	50
Moderately polluted <sup>1</sup>				
Low	50	200	500	50
High	100	400	100	10
Very polluted <sup>2</sup>	>100	>400	100	10

1. For intermediate values between 50 and 100 µg/m<sup>3</sup> linear interpretation should be used.
2. No project with sulfur dioxide emissions will be recommended.

**B. Nitrogen Oxides**

Annual arithmetic mean of ambient air concentrations of nitrogen oxides (expressed as NO <sub>2</sub> ) should not exceed	100 µg/m <sup>3</sup> (0.05 ppm)
Maximum emission levels for stationary source discharges, before mixing with the atmosphere: For fuel fired steam generators	
Liquid fossil fuel	130 ng/J of heat input
Solid fossil fuel	300 ng/J of heat input
Lignite fossil fuel	260 ng/J of heat input

**Exhibit A.4: National Environmental Quality Standards for Motor Vehicle Exhaust and Noise**

No.	Parameter	Standards (Maximum Permissible Limit)	Measuring Method
1.	Smoke	40% or 2 on the Ringelmann Scale during engine acceleration mode.	To compared with Ringlemann chart at a distance of 6 meters or more.
2.	Carbon Monoxide	Emission Standards: New Vehicles 4.5%	Used Vehicles 6%
			Under idling conditions: Nondispersive infrared detection through gas analyzer.
3.	Noise	85 db (A)	Sound-meter at 7.5 meters from the source.

## **Appendix B: Ambient Air Quality Measurement Results**

---

See the following page.

**Exhibit B.1: Site No1 Results****SITE ID:** ECPL Colony (Market Parking)**DATE:** March 9, 2007**CITY:** Daharki**Site No.:** One

<i>Time</i>	<i>SO<sub>2</sub></i> <i>(ppb)</i>	<i>NO<sub>x</sub></i> <i>(ppb)</i>	<i>CO</i> <i>(ppm)</i>	<i>Dust</i> <i>(µg/m<sup>3</sup>)</i>
13:00	9.3	14.3	0.98	75
13:15	9.2	14.2	0.95	74
13:30	9.3	14.3	0.96	75
13:45	9.4	14.4	0.86	74
14:00	9.6	14.6	0.87	76
14:15	9.2	14.2	0.65	74
14:30	9.3	14.3	0.64	78
14:45	9.4	14.4	0.63	85
15:00	9.9	14.9	0.62	87
15:15	9.2	14.2	0.65	74
15:30	8.9	13.9	0.68	78
15:45	9.3	14.3	0.63	85
16:00	9.3	14.3	0.64	86
16:15	9.4	14.4	0.68	74
16:30	9.6	14.6	0.69	75
16:45	9.3	14.3	0.68	78
17:00	10.4	15.4	0.65	74
17:15	10.6	15.6	0.63	78
17:30	11.6	16.6	0.62	77
17:45	12.5	17.5	0.63	79
18:00	12.6	17.6	0.67	79
18:15	12.7	17.7	0.74	74
18:30	12.3	17.3	0.84	78
18:45	12.6	17.6	0.89	75
19:00	13.2	18.2	0.85	74
19:15	13.3	18.3	0.96	76
19:30	13.1	18.1	1.24	74
19:45	12.2	17.2	1.23	78
20:00	12.9	17.9	1.25	74

*Continues...*

...Continued

<i>Time</i>	<i>SO<sub>2</sub></i> <i>(ppb)</i>	<i>NO<sub>x</sub></i> <i>(ppb)</i>	<i>CO</i> <i>(ppm)</i>	<i>Dust</i> <i>(µg/m<sup>3</sup>)</i>
20:15	12.2	17.2	1.23	75
20:30	13.1	18.1	1.26	74
20:45	13.9	18.9	1.32	78
21:00	13.4	18.4	1.35	74
21:15	12.3	17.3	1.23	75
21:30	10.1	15.1	1.25	78
21:45	9.8	14.8	1.23	74
22:00	9.2	14.2	1.25	75
22:15	9.6	14.6	1.24	74
22:30	10.6	15.6	1.23	78
22:45	10.5	15.5	1.13	74
23:00	11.1	16.1	1.11	75

**Exhibit B.2: Site No2 Results****SITE ID:** Plant Area**DATE:** March 10, 2007**CITY:** Daharki**Site No.:** Two

<i>Time</i>	<i>SO<sub>2</sub></i> <i>(ppb)</i>	<i>NO<sub>x</sub></i> <i>(ppb)</i>	<i>CO</i> <i>(ppm)</i>	<i>Dust</i> <i>(µg/m<sup>3</sup>)</i>
0:00	10.4	15.4	0.87	78
0:15	10.9	15.9	0.74	74
0:15	10.9	15.9	0.74	74
1:00	7.8	14.3	1.3	98
1:15	7.5	13.2	1.4	96
1:30	7.9	13.5	1.2	98
1:45	7.4	13.2	1.5	95
2:00	7.8	12.3	1.3	96
2:15	7.6	12.1	1.2	97
2:30	7.4	13.4	1.3	96
2:45	7.3	12.6	1.2	95
3:00	7.4	13.5	1.4	98
3:15	7.2	13.4	1.2	96
3:30	7.6	12.6	1.3	98
3:45	6.8	12.5	1.3	96
4:00	6.4	12.7	1.2	95
4:15	7.3	12.6	1.5	96
4:30	6.9	12.4	1.4	96
4:45	8.4	12.3	1.3	94
5:00	7.5	12.7	1.2	96
5:15	7.6	12.5	1.3	98
5:30	8.4	12.4	1.1	96
5:45	8.3	12.3	1.2	98
6:00	6.4	12.4	1.3	96
6:15	6.2	12.6	1.5	85
6:30	7.3	12.9	1.2	96
6:45	6.8	11.3	1.2	98
7:00	7.8	11.5	1.3	96
7:15	8.4	12.8	1.1	98
7:30	8.3	11.4	1.2	96

*Continues...*

...Continued

<i>Time</i>	<i>SO<sub>2</sub></i> <i>(ppb)</i>	<i>NO<sub>x</sub></i> <i>(ppb)</i>	<i>CO</i> <i>(ppm)</i>	<i>Dust</i> <i>(µg/m<sup>3</sup>)</i>
7:45	8.2	13.1	1.3	92
8:00	7.9	11.6	1.1	93
8:15	7.5	11.2	1.0	91
8:30	7.6	11.3	1.1	98
8:45	7.4	11.4	1.3	96
9:00	8.4	11.2	1.2	95
9:15	8.4	11.6	1.3	93
9:30	8.6	11.5	1.4	94
9:45	7.5	11.3	1.2	96
10:00	6.8	11.2	1.3	95
10:15	6.4	11.9	1.2	93
10:30	6.3	12.4	1.4	95
10:45	6.9	12.6	1.3	93
11:00	6.7	12.4	1.2	86
11:15	8.5	12.9	1.2	94
11:30	8.9	12.1	1.2	96
11:45	7.6	12.6	1.3	96
12:00	7.5	12.4	1.1	97
12:15	6.8	12.3	1.2	95
12:30	8.2	12.1	1.2	95
12:45	6.2	12.4	1.3	96

## Appendix C: Flora and Fauna

**Exhibit C.1: Plants found in the Project area**

<i>Local Name</i>	<i>Botanical Name</i>	<i>Family</i>	<i>Distribution</i>
Babul	<i>Acacia nilotica</i>	Mimosaceae	Pakistan, India
Nim	<i>Azadirachta indica</i>	Meliaceae	Native of India and China, cultivated and naturalized in India, Malaysia and Pakistan
Khajoor	<i>Phoenix dactylifera</i>	Palmae	Native to W. Asia and N. Africa, widely domesticated in Punjab and Sindh, cultivated in lower Balochistan and NWFP
	<i>Tamarix indica</i>	Tamaricaceae	Bangladesh, Sri Lanka, India, Pakistan and Afghanistan
Ghaz	<i>Tamarix aphylla</i>	Tamaricaceae	Africa, Middle East, Pakistan, India and Afghanistan
Lai	<i>Tamarix dioica</i>	Tamaricaceae	Pakistan, Iran, Afghanistan, India, Nepal, Bangladesh and Burma
Ber	<i>Ziziphus mauritiana</i>	Rhamnaceae	India, Pakistan, Afghanistan, Sri Lanka, China, Australia, Tropical Africa
Booi	<i>Aerva javanica</i>	Amaranthaceae	Burma, India, Sri Lanka through SW Asia and across N. Africa. Introduced in Australia and elsewhere
Vilayati Dahi	<i>Prosopis glandulosa</i>	Mimosaceae	Native of S. United States and N. Mexico, naturalised in Punjab and Sindh
Dahi	<i>Prosopis juliflora</i>	Mimosaceae	Indigenous to W. Indies and Mexico, widely naturalised in Sindh and Punjab
Ak	<i>Calotropis procera</i>	Asclepiadaceae	Pakistan, India, Afghanistan, Iran, Iraq
Tikandri	<i>Tribulus terrestris</i>	Zygophyllaceae	Tropical and sub-tropical Asia, Africa, S. Europe, N. Australia. Common throughout Pakistan up to 3500 m. in sandy soils of barren lands and cultivated fields as a weed
Dhini	<i>Ochthochloa compressa</i>		Pakistan, NW India to N. Africa
Sar	<i>Saccharum spontaneum</i>		Pakistan, warmer regions of the Old World

**Exhibit C.2: Birds Found in Project Area**

<i>Common Name</i>	<i>Scientific Name</i>	<i>Observed</i>	<i>Reported</i>
<b>Phasianidae</b>			
Common quail	<i>Coturnix coturnix</i>	✓	✓
<b>Dacelonidae</b>			
Common kingfisher	<i>Alcedo atthis</i>	✓	✓
<b>Columbidae</b>			
Laughing dove (little brown dove)	<i>Streptopelia senegalensis</i>	✓	✓
Eurasian (Indian) collared dove	<i>Streptopelia decaocto</i>		✓
<b>Gruidae</b>			
Common crane	<i>Grus grus</i>		✓
<b>Podicipididae</b>			
Little grebe	<i>Tachybaptus ruficollis</i>		✓
Great cormorant	<i>Phalacrocorax carbo</i>		✓
<b>Ardeidae</b>			
Little egret	<i>Egretta garzetta</i>	✓	✓
Cattle egret	<i>Bubulcus ibis</i>		✓
Indian pond-heron	<i>Ardeola grayii</i>	✓	✓
Yellow bittern	<i>Ixobrychus sinensis</i>		✓
<b>Corvidae</b>			
House crow	<i>Corvus splendens</i>	✓	✓
<b>Muscicapidae</b>			
Indian robin	<i>Saxicoloides fulicata</i>	✓	✓
Desert wheatear	<i>Oenanthe deserti</i>		✓
<b>Sturnidae</b>			
Rosy starling (rosy pastor)	<i>Sturnus roseus</i>	✓	✓
Common starling	<i>Sturnus vulgaris</i>		✓
Common myna	<i>Acridotheres tristis</i>	✓	✓
<b>Pycnonotidae</b>			
White-cheeked (Himalayan) bulbul	<i>Pycnonotus leucogenys</i>	✓	✓
<b>Sylviidae</b>			
Desert Warbler	<i>Sylvia nana</i>	✓	✓
Common tailorbird	<i>Orthotomus sutorius</i>		✓
Common babbler	<i>Turdoides caudatus</i>	✓	✓

Continues...

...Continued

<i>Common Name</i>	<i>Scientific Name</i>	<i>Observed</i>	<i>Reported</i>
<b>Alaudidae</b>			
Desert lark (desert finch-lark)	<i>Ammomanes deserti</i>	✓	✓
Eurasian skylark	<i>Alauda arvensis</i>		✓
<b>Passeridae</b>			
House sparrow	<i>Passer domesticus</i>	✓	✓
White wagtail	<i>Motacilla maderaspatensis</i>	✓	✓
Yellow wagtail	<i>Motacilla flava</i>	✓	✓

**Exhibit C.3: Mammals found or reported in the Project area**

<i>Order and Family</i>	<i>Common Name</i>	<i>Scientific Name</i>	<i>Observed</i>	<i>Reported</i>
<b>Insectivora</b>				
Erinaceidae	Indian hedgehog	<i>Paraechinus micropus</i>		✓
<b>Carnivora</b>				
Canidae	Asiatic jackal	<i>Canis aureus</i>	✓	✓
Canidae	Common red fox	<i>Vulpes vulpes pusilla</i>	✓	✓
<b>Rodentia</b>				
Sciuridae	Five striped palm squirrel	<i>Funambulus pennanti</i>	✓	✓
Hystriidae	Indian crested porcupine	<i>Hystrix indica</i>	✓	✓
Muridae	House mouse	<i>Mus musculus</i>	✓	✓
Muridae	Indian gerbil	<i>Tatera indica</i>	✓	✓
Muridae	Indian desert jird	<i>Meriones hurrianae</i>	✓	✓

**Exhibit C.4: Reptiles found or reported in the Project area**

<i>Common Name</i>	<i>Scientific Name</i>	<i>Observed</i>	<i>Reported</i>
<b>Agamidae</b>			
Ground agama	<i>Trapelus agilis</i>	✓	✓
Afghan ground agama	<i>Agama megalonyx</i>		✓
Indian garden lizard	<i>Calotes versicolor</i>		✓
<b>Scincidae</b>			
Indian sand-swimmer	<i>Ophiomorus tridactylus</i>	✓	✓
<b>Varanidae</b>			
Indian desert monitor	<i>Varanus griseus koniecznyi</i>		✓

**Exhibit C.5: Amphibians reported in the Project area**

<i>Common Name</i>	<i>Zoological Name</i>	<i>Observed</i>	<i>Reported</i>
Indian Toad	<i>Bufo stomaticus</i>		✓
Toad	<i>Bufo surdus</i>		✓
Skittering Frog	<i>Rana cyanophlyctis</i>		✓
Tiger Frog	<i>Rana tigrina</i>		✓
Burrowing Frog	<i>Rana breviceps</i>		✓

## Appendix D: Environmental Management Plan

---

### CONTENTS

<b>1.</b>	<b>Introduction.....</b>	<b>1-1</b>
<b>2.</b>	<b>Construction Phase EMP.....</b>	<b>2-2</b>
2.1	Purpose and Objectives of the EMP .....	2-2
2.2	Management Approach .....	2-2
2.3	Management Responsibilities .....	2-2
2.4	Components of the EMP .....	2-3
<b>3.</b>	<b>Mitigation Plan .....</b>	<b>3-1</b>
<b>4.</b>	<b>Monitoring Plan .....</b>	<b>4-1</b>
4.1	Objectives of Monitoring.....	4-1
4.2	Environmental Monitoring Plan.....	4-1
4.3	Environmental Record.....	4-1
<b>5.</b>	<b>Communication and Documentation.....</b>	<b>5-1</b>
5.1	Meetings .....	5-1
5.2	Reports .....	5-1
5.3	Change-Record Register.....	5-1
<b>6.</b>	<b>Change Management .....</b>	<b>6-1</b>
6.1	Changes to the Operation .....	6-1
6.2	First-Order Change .....	6-1
6.3	Second-Order Change.....	6-1
6.4	Third-Order Change.....	6-1
6.5	Changes to the EMP .....	6-1
<b>7.</b>	<b>Environmental Training .....</b>	<b>7-1</b>
<b>8.</b>	<b>Operation Phase EMP .....</b>	<b>8-1</b>
8.1	Environmental Management System .....	8-1
8.2	Scope of the EMP.....	8-1
	<b>Annexure A: ECPL Environmental Management System Manual.....</b>	<b>8-2</b>

## Abbreviation

---

EIA	Environmental Impact Assessment
EMP	Environmental Management Plan
EPA	Environmental Protection Agency
HBP	Hagler Bailly Pakistan (Pvt.) Limited
IEE	Initial Environmental Examination
IFC	International Finance Corporation
IUCN	World Conservation Union
MMscfd	Million standard cubic feet per day
NEQS	National Environmental Quality Standards
NGO	Non-Governmental Organizations
Nm <sup>3</sup> /h	Normal cubic meter (m <sup>3</sup> ) per hour
NSC	Pakistan National Conservation Strategy
Pak-EPA	Pakistan Environmental Protection Agency
PEPC	Pakistan Environmental Protection Council
PPS	[IFC's] Policy and Performance Standards
RoW	Right of Way
SEPA	Sindh Environmental Protection Agency
tpy	tons per year
WWF	World Wide Fund for Nature

# 1. Introduction

---

This document provides the environmental management plan (EMP) of the proposed expansion project. The EMP for the construction phase is provided in detail in **Sections 2 to 7**.

In Section 8, the outline and key features of the EMP for the operations phase is presented. The operation phase EMP will be developed before commissioning on the basis of the outline and when other details of the project are available. As per the environmental legislation in Pakistan, the EMP for the operations phase, along with other documents, is to be submitted to the relevant environmental protection agency prior to the project commissioning in order to obtain confirmation for compliance and environmental approval for project operation.

## 2. Construction Phase EMP

---

### 2.1 Purpose and Objectives of the EMP

The primary objectives of the EMP are to:

- ▶ Facilitate the implementation of the mitigation measures identified for construction phase in the EIA
- ▶ Define the responsibilities of the project proponent and contractor and provide a means of effective communication of environmental issues between them
- ▶ Identify monitoring parameters in order to ensure the effectiveness of the mitigation measures
- ▶ Provide a mechanism for taking timely action in the face of unanticipated environmental situations
- ▶ Identify training requirements at various levels.
- ▶ The EMP is prepared on the basis of the details currently available on the construction phase of the project. As construction contractor is appointed and further information, the EMP will be amended to reflect the change. However, no mitigation measures committed in the EMP can be changed.

### 2.2 Management Approach

The organizational roles and responsibilities of the key players are summarized below:

**ECPL:** The project proponent will undertake overall responsibility for compliance with the EMP. ECPL will carry out verification checks to ensure that the contractors are effectively implementing their environmental and social requirements.

**Contractors:** The contractors will implement the majority of environmental and social mitigations as required by their contract with ECPL. The contractors will carry out field activities as part of the proposed project. The contractors are subject to certain liabilities under the environmental laws of the country, and under its contract with ECPL.

### 2.3 Management Responsibilities

The responsibilities of the client and contractor are briefly described below:

- ▶ Primary responsibilities:
  - ▷ As regards environmental performance during the project, the respective highest-ranking officers in the country will assume the primary responsibilities on behalf of both the project proponent and contractor.
  - ▷ ECPL's Project Manager will be responsible for EIA and EMP compliance throughout the project on behalf of the company itself.
  - ▷ ECPL will coordinate with the concerned government departments.

- ▶ Project management and quality control:
  - ▷ Carrying out construction activities in an environmentally sound manner during the project will be the responsibility of the contractor's site manager.
  - ▷ ECPL's Construction representative will be responsible for the overall environmental soundness of all field operations

Specific roles and responsibilities for environmental monitoring are provided in **Exhibit 2.1**.

## **2.4 Components of the EMP**

The EMP consists of the following:

- ▶ Mitigation plan
- ▶ Monitoring Plan
- ▶ Communication and documentation
- ▶ Change management
- ▶ Environmental training

**Exhibit 2.1: Roles and Responsibilities for Environmental Monitoring**

<i>Aspect</i>	<i>ECPL Responsibilities</i>	<i>Contractor's Responsibilities</i>	<i>Relevant Documentation</i>
Contracting	Ensure that the monitoring requirements are included in the contract between ECPL and the construction contractor(s)	Understand the requirements and estimating the required resources	Contract between ECPL and the construction contractor(s)
Monitoring plan	Finalize the monitoring plan prior to commencement of construction		Revised monitoring plan
Resources	Ensure the availability of resources required for environmental monitoring	Ensure the availability of resources required for environmental monitoring	Project budgets
Environmental staff	Designate an Environmental Manager for the project	Appoint an officer dedicated to environment (may be combined with health and safety)	Job descriptions
Monitoring surveys and inspections	Undertake periodic inspections and carry out field measurements, where needed	Systematically observe and collect data on the environmental performance, undertake inspections, and carry out surveys	Inspection and survey reports
Environmental audit	Conduct periodic audits of the construction sites and commissioning third party audits	Conducting periodic internal audits	Audit reports
Reporting	Ensuring that periodic environmental monitoring reports are received from the contractor(s) and review the reports	Generate periodic environmental monitoring reports and disseminating these among the management and appropriate staff members	Periodic reports
Corrective actions	Verify that the activities are carried out comply with the EIA/EMP and identify corrective actions, if needed	Carry-out the required corrective actions	Corrective action record
Maintenance of record	Maintain monitoring data and record of all incidents of environmental significance and related corrective measures	Maintain monitoring data and record of all incidents of environmental significance and related corrective measures	Environmental databases

### 3. Mitigation Plan

---

The mitigation plan is a key component of the EMP. It lists all the mitigation measures identified in the EIA and the associated environmental or social aspect. The mitigation measures for plant construction are presented in **Exhibit 3.1**. The measures are organized under the following environmental aspects of the project activities:

- ▶ Construction noise control plan
- ▶ Dust emission
- ▶ Vehicle and equipment exhaust
- ▶ Soil contamination
- ▶ Hazardous and non-hazardous waste management plan

**Exhibit 3.1: Mitigation Plan for Construction Phase**

<i>No</i>	<i>Environmental or Social Aspects</i>	<i>ID</i>	<i>Measure</i>	<i>Responsibility</i>
1	Construction Noise Control Plan	1.1	Periodic surveys will be conducted for noise levels from construction equipments, operational machinery and vehicles.	Construction Contractor
		1.2	Noise control measures will be implemented if the results of surveys indicate non-compliance to the acceptable limits. If needed, restricted activity zones, will be identified. Construction work within the restricted zone(s) will be managed.	Construction Contractor
		1.3	All high noise activities will be scheduled during the day time	Construction Contractor
		1.4	A noise wall will be constructed along the southern boundary of the ECPL property to provide additional noise abatement at the MGCL colony	Construction Contractor, ECPL
		1.5	Blowing of horns will be prohibited and construction traffic will be kept to a minimum during night time	Construction Contractor
2	Dust Emission Control Plan	2.1	Water will be sprinkled on all exposed surfaces to suppress emission of dust Frequency of sprinkling will be kept such that the dust remains under control.	Construction Contractor Construction Contractor
		2.2	Dust emission from soil piles and aggregate storage stockpiles will be reduced by keeping the material moist by sprinkling of water at appropriate frequency or erecting windshield walls on three sides of the piles such that the wall project 0.5 m above the pile, or covering the pile, for example with tarpaulin or thick plastic sheets, to prevent emission.	Construction Contractor
3	Vehicle and Equipment Exhaust Control Plan	3.1	All vehicles, generators and other equipment used during the construction will be tuned and maintained in good working condition in order to minimize emission of pollutants	Construction Contractor
		3.2	The stack height of the generators will be at least 3 m above the ground	Construction Contractor, ECPL

*Continues...*

...Continued

No	Environmental or Social Aspects	ID	Measure	Responsibility
4	Soil Contamination	4.1	Spill prevention trays will be provided and used at refueling locations	Construction Contractor
		4.2	On-site maintenance of construction vehicles and equipment will be avoided as far as possible.	Construction Contractor
		4.3	In case on-site maintenance is unavoidable, tarpaulin or other impermeable material will be spread on the ground to prevent contamination of soil.	Construction Contractor
		4.4	Regular inspections will be carried out to detect leakages in construction vehicles and equipment.	Construction Contractor
		4.5	All vehicles will be washed in external commercial facilities.	Construction Contractor
		4.6	Fuels, lubricants, and chemicals will be stored in covered bounded areas, underlain with impervious lining.	Construction Contractor
		4.7	Appropriate arrangements, including shovels, plastic bags and absorbent materials, will be available near fuel and oil storage areas.	Construction Contractor
		4.8	Contaminated soil will be removed from the site and taken to the incineration.	Construction Contractor
		4.9	Emergency plan for spill management will be prepared and inducted to the staff for any incident of spill	Construction Contractor, ECPL
5	Hazardous and Non-Hazardous Waste Management Plan	5.1	Recyclable material will be separated at source and delivered to a designated waste recycler	Construction Contractor, ECPL
		5.2	Waste bins for the construction waste will be constructed inside the plant boundary. No waste will be dumped at any location outside the boundary.	Construction Contractor, ECPL
		5.3	All hazardous waste will be separated from other wastes; hazardous waste such as oily waste will be disposed of through licensed oily waste contractors	Construction Contractor, ECPL
		5.4	On-site storage facility for hazardous waste will be developed to hold hazardous waste until an off-site hazardous waste disposal facility is available	Construction Contractor, ECPL

Continues...

...Continued

No	Environmental or Social Aspects	ID	Measure	Responsibility
		5.5	Records of all waste generated during the construction period will be maintained.	Construction Contractor, ECPL
		5.6	Quantities of waste disposed, recycled, or reused will be logged on a Waste Tracking Register	Construction Contractor, ECPL
		5.7	All non-hazardous waste material that cannot be recycled or reused will be incinerated	Construction Contractor, ECPL
		5.8	The possibility of returning the packaging to the manufacturers for reuse will be explored.	Construction Contractor, ECPL
		5.9	Chemical containers (including partially full containers) will be returned to vendors	Construction Contractor, ECPL
		5.10	An emergency response plan will be developed for the hazardous waste (and substances)	Construction Contractor, ECPL
		5.11	Training will be provided to personnel for identification, segregation, and management of waste	Construction Contractor, ECPL
		5.12	All containers of hazardous waste will be appropriately labeled.	Construction Contractor, ECPL
		5.13	Equipment and material containing asbestos, poly-chlorinated biphenyls (PCBs), and ozone depleting substances (ODSs) will not be used.	Construction Contractor, ECPL

## 4. Monitoring Plan

---

Environmental monitoring is a vital component of the environmental management plan. It is the mechanism through which the effectiveness of the environmental management plan in protecting the environment is measured. The feedback provided by the environmental monitoring is instrumental in identifying any problems and planning corrective actions.

### 4.1 Objectives of Monitoring

The main objectives of the environmental monitoring during the construction phase of the proposed expansion plan will be:

- ▶ To provide a mechanism to determine whether the project construction contractors are carrying out the project in conformity with the EMP
- ▶ To identify areas where the impacts of the projects are exceeding the criteria of significance and, therefore, require corrective actions
- ▶ To document the actual project impacts on physical, biological, and socioeconomic receptors, quantitatively where possible, in order to design better and more effective mitigation measures
- ▶ To provide data for preparing the monitoring report to be submitted to the SEPA after the completion of the construction phase.

### 4.2 Environmental Monitoring Plan

The detailed monitoring plan will be finalized prior to commencement of the construction. The environmental monitoring requirements assessed in the EIA are presented in **Exhibit 4.1**.

### 4.3 Environmental Record

Following environmental record will be maintained:

- ▶ Periodic inspection reports of Contractor's Environmental Officer and ECPL Environmental Manager or his designate
- ▶ Audit reports
- ▶ Incident record of all moderate and major spills. The record will include:
  - ▷ Location of spill
  - ▷ Estimated quantity
  - ▷ Spilled material
  - ▷ Restoration measures
  - ▷ Photographs
- ▶ Description of any damage to vegetation, water resource, or community asset

- ▶ Corrective measures taken, if any.
  - ▷ Waste Tracking Register that will records of all waste generated during the construction period. This will include quantities of waste disposed, recycled, or reused.
  - ▷ Records of water consumption with use wise breakdown
  - ▷ Survey reports, in particular, the following:
- ▶ Soil erosion: Baseline survey, including photographs (or video), will be conducted to document pre-construction condition of the construction corridor
- ▶ Vehicle and equipment noise
- ▶ Ambient noise survey reports
  - ▷ Vendor data—All vendors disturbed by the project and compensation paid
  - ▷ Public infrastructure: Record of all damages and repair work undertaken.
  - ▷ Employment
- ▶ Total number of unskilled, semi-skilled, and skilled jobs offered during construction
- ▶ Name and domicile of the employed staff
  - ▷ Archeological resources—Record of any finds with photographs.
  - ▷ Project and Community Interface
- ▶ Record of community complains and the measures taken to address them.
- ▶ Number of meeting held in various communities and persons who attended
  - ▷ Environmental and social training records

**Exhibit.4.1: Monitoring Requirements**

<i>Project Activity and Potential Impact</i>	<i>Objective of Monitoring</i>	<i>Parameters to be Monitored</i>	<i>Measurements</i>	<i>Location</i>	<i>Frequency</i>	<i>Responsibility</i>
<b>Noise</b> Disturbance due to noise from construction activity	To determine the effectiveness of noise abatement measures on sound pressure levels	Ambient noise level near receptors	A-weighted noise levels – 24 hours, readings taken at 15 s intervals over 15 min. every hour, and then averaged	At three locations on the plant boundary and three location at the receptor level. At two point along the RoW	<b>Baseline before start of construction:</b> On three typical working days and one weekend <b>During construction:</b> Once every four weeks on a typical working day	Contractor's Environmental officer, ECPL
	To determine the effectiveness of noise control measures on the sound pressure level of the noise sources	Source noise level of generators, major equipment and large vehicles	A-weighted noise levels measured at 15 m from the source in four directions. Measurement should be taken at full throttle, typical operating and idling conditions	15.2 m from the source in four direction	Once in 3 months	Contractor's Environmental officer, ECPL
<b>Air Quality</b> Dust emissions from construction equipment working on construction sites	To determine the effectiveness of dust control program on dust at receptor level	PM10 (particulate matter smaller than 10 microns) concentration at receptor level	1-hr and 24-hr concentration levels	At three representative locations	<b>Baseline before start of construction:</b> On three typical working days and one weekend <b>During construction:</b> Once every four weeks on a typical working day	Contractor's Environmental officer, ECPL
		Visible dust	Visual observation of size of dust clouds, their dispersion and the direction of dispersion	construction sites	Once daily during peak construction period	Contractor's Environmental officer, ECPL

Continues...

...Continued

<i>Project Activity and Potential Impact</i>	<i>Objective of Monitoring</i>	<i>Parameters to be Monitored</i>	<i>Measurements</i>	<i>Location</i>	<i>Frequency</i>	<i>Responsibility</i>
<b>Air Quality</b> Exhaust emissions from generators and construction equipment	To determine the effectiveness of gaseous emission control measures on source emission	Gaseous emission rates from generators and other key equipment	CO, NO <sub>x</sub> , SO <sub>2</sub> and PM. Measurement should be taken at full throttle, typical operating and idling conditions	Exhaust	Baseline when the equipment is inducted in pool and once three months subsequently	Contractor's Environmental officer, ECPL
<b>Soil Erosion</b> Soil erosion due to wind from exposed surfaces	To determine the effectiveness of erosion control measures	Inspection for signs of erosion during and after the construction and post-reinstatement	Visual inspections	Dust	On weekly basis	Contractor's Environmental officer, ECPL
<b>Soil Contamination</b> Contamination due to leakages of oil and chemicals on ground	To determine the effectiveness of control measures taken to minimize the risk of spillages of oil and chemicals	Procedures in place to handle liquids and availability of procedures and equipments for emergency response incidents	Visual inspections and availability checks	Plant and pipeline construction sites	Weekly inspections	Contractor's Environmental officer, ECPL
<b>Waste Disposal</b> Insufficient procedures for waste collection, storage, transportation and disposal	To check the availability of waste management system and implementation	Inspection of waste generation, collection, segregation, storage, recycling and disposal will be undertaken at each site of the project activity	Visual inspections	Plant and pipeline construction sites and camp sites	Once daily	Contractor's Environmental officer, ECPL

## 5. Communication and Documentation

---

An effective mechanism to store and communicate environmental information during the project is an essential requirement of an EMP.

### 5.1 Meetings

Two kinds of environmental meetings will take place during the project:

- ▶ Kick-off meetings
- ▶ Weekly meetings.

The purpose of the kick-off meeting will be to present the EMP to project staff and discuss its implementation.

A weekly meeting will be held during construction operations at site. The purpose of this meeting will be to discuss the conduct of the operation and environmental issues and their management. The proceedings of the meeting will be recorded in the form of a weekly environmental report.

### 5.2 Reports

Environmental reports will be prepared on a weekly basis.

### 5.3 Change-Record Register

A change-record register will be maintained at the site, in order to document any changes in project design. These changes will be handled through the change management mechanism discussed later in this document, and reported to the SEPA.

## 6. Change Management

---

An environmental assessment of the proposed project has been made on the basis of the project description available at the time the EIA was prepared. However, it is possible that changes in project design may be required at the time of project implementation. This section describes the mechanism that will be put into place to manage changes that might affect the project's environmental impacts.

### 6.1 Changes to the Operation

Potential changes in project design have been categorized as first-order, second-order, and third-order changes. These are defined below.

### 6.2 First-Order Change

A first-order change is one that leads to a significant departure from the project described in the EIA and consequently requires a reassessment of the environmental impacts associated with the change.

In such an instance, the environmental impacts of the proposed change will be reassessed, and the results sent to the SEPA for approval.

### 6.3 Second-Order Change

A second-order change is one that entails project activities not significantly different from those described in the EIA, and which may result in project impacts whose overall magnitude would be similar to the assessment made in this report.

In case of such changes, the environmental impact of the activity will be reassessed, additional mitigation measures specified if necessary, and the changes reported to the SEPA.

### 6.4 Third-Order Change

A third-order change is one that is of little consequence to the EIA findings. This type of change does not result in impact levels exceeding those already assessed in the EIA; rather these may be made onsite to minimize the impact of an activity. The only action required in this case will be to record the change in the change record register.

### 6.5 Changes to the EMP

Changes in project design may necessitate changes in the EMP. In this case, the following actions will be taken:

- ▶ A meeting will be held between ECPL and the contractor representatives, to discuss and agree upon the proposed addition to the EMP.
- ▶ Based on the discussion during the meeting, a change report will be produced collectively, which will include the additional EMP clause and the reasons for its addition.
- ▶ A copy of the report will be sent to the head offices of ECPL and the contractor.
- ▶ All relevant project personnel will be informed of the addition.

## 7. Environmental Training

Environmental training will help to ensure that the requirements of the EIA and EMP are clearly understood and followed by all project personnel in the course of the project. The contractor will be primarily responsible for providing training to all project personnel. An indicative environmental and social training program is provided in **Exhibit 7.1**, which will be finalized before the commencement of the project.

**Exhibit 7.1: Training Program**

<i>Target Audience</i>	<i>Trainers</i>	<i>Contents</i>	<i>Schedule</i>
Selected management staff from contractor	Contractor	Key findings of EIA Mitigation measures EMP	Prior to the start of project activities
All site personnel	Contractor	Mitigation measures Camp Rules	Prior to the start of project activities
Construction crew	Contractor	EMP Waste disposal procedures	Prior to the start of construction activities
Drivers	Contractor	Road safety Road access restrictions Vehicle movement restrictions Dust reduction Waste disposal	Before and during field operations
Mechanics	Contractor	Waste disposal Vehicle movement restrictions	Before and during field operations
Camp staff	Contractor	Camp operation Waste disposal Natural resource conservation Housekeeping Camp Rules	Before and during field operations

## 8. Operation Phase EMP

---

This section outlines the aspects that will be covered in the EMP for the operational phase of the ECPL expansion project. The purpose of an EMP is not only to address the expected environmental impacts of a project, but also to enhance project benefits, and to introduce standards of good practice to be adopted for all projects works.

### 8.1 Environmental Mangement System

ECPL has a track record of responsible environmental management in operations. ECPL is an ISO 14000 certified company and will conduct the operation of the project as per its environmental management system (EMS). The basic outline of EMS of ECPL is presented in **Annexure A** for reference.

### 8.2 Scope of the EMP

The EMP will address the mitigation measures committed by the project proponents in this EIA study, the mitigation plan to be employed during the operational phase, the monitoring, communication, and documentation of activities pertaining to the environmental management of the project operation, the necessary trainings that would be provided to the key staff members, the emergency response plan, and the community development plan that the project proponents will have in place.

#### ***Mitigation Plan***

The mitigation plan for the project operation will be developed in line with the findings of this report and will cover the following areas:

- ▶ Plant Noise
- ▶ Wastewater
- ▶ Emission
- ▶ Accidental Release of ammonia
- ▶ Water Resources
- ▶ Hazardous Material
- ▶ Waste Management


#### ***Monitoring Plan, Communication, and Documentation***

The monitoring of the EMP and the communication and documentation mechanism that will be employed during the operational phase will be based on the Environmental Management System (EMS) of the project proponents.

# **Annexure A: ECPL Environmental Management System Manual**


---

See next page

 <b>ECPL Manufacturing Division</b>	<h1>Environmental Management System Manual</h1>	Document No. SET/EMSM/001 Rev. No. 00 Issue No. 01 Effective Date Sep 01, 2003 Page No. Pg 1 of 32 Orig. Prep. by KKn / Sep, 2003
<b>Department: SET</b>	<b>Unit/Section: Env</b>	<b>Area: Environment</b>

## TABLE OF CONTENTS

SEC.	DESCRIPTION	PAGE NO
<b>1</b>	<b>Environmental Management System Manual (Document Approval Page)</b>	1
1.1	Table of Change record	2
1.2	Table of Contents	3
1.3	Introduction to ISO-14001	4
<b>2</b>	<b>Company Profile and Scope</b>	5
<b>3</b>	<b>Definitions and Abbreviations</b>	7
3.1	EMS Model	10
<b>4</b>	<b>ENVIRONMENTAL MANAGEMENT SYSTEM REQUIREMENTS</b>	
<b>4.1</b>	<b>General Requirements</b>	
<b>4.2</b>	<b>Environmental Policy</b>	11
<b>4.3</b>	<b>Planning</b>	13
4.3.1	Environmental Aspects	15
4.3.2	Legal and other requirements	17
4.3.3	Environmental Objectives and Targets	18
4.3.4	Environmental Management Program	19
<b>4.4</b>	<b>Implementation and Operation</b>	
4.4.1	Structure and Responsibility	20
4.4.2	Training, Awareness and Competence	21
4.4.3	Communication	22
4.4.4	Environmental Management System Documentation	23
4.4.5	Document Control	24
4.4.6	Operational Control	25
4.4.7	Emergency Preparedness and Response	26
<b>4.5</b>	<b>Checking and Corrective Action</b>	
4.5.1	Monitoring and Measurement	27
4.5.2	Nonconformance and Corrective and Preventive Action	28
4.5.3	Records	29
4.5.4	Environmental Management system Audit	30
<b>4.6</b>	<b>Management Review</b>	31
	List of Environmental Management System Procedures	32

 <b>ECPL Manufacturing Division</b>	<h1>Environmental Management System Manual</h1>	Document No. SET/EMSM/001 Rev. No. 00 Issue No. 01 Effective Date Sep 01, 2003 Page No. Pg 1 of 32 Orig. Prep. by KKn / Sep. 2003
<b>Department: SET</b>	<b>Unit/Section: Env</b>	<b>Area: Environment</b>

## SECTION 1.3 : INTRODUCTION TO ISO-14001

### Purpose:

The purpose of this document is to provide an introduction to ISO 14001.

### Document Controller:

**SET Manager** shall be the owner of this document, responsible for stewarding updates, review, approval, distribution and control of change.

### INTRODUCTION:

The standard is applicable to all types and sizes of organizations. It's meant to accommodate diverse geographical, cultural, and social conditions and to be successfully applied every where.

The standard does not establish "absolute requirements for environmental performance beyond commitment, in the policy, to compliance with applicable legislation and regulations and to continual improvement."

The EMS described in ISO-14001 applies to those environmental aspects which the ECPL can control and over which it can be expected to have an influence. **It does not itself state specific environmental performance criteria.**

The basic purpose of an EMS is to provide ECPL with a structured process and a framework with which to achieve and systematically control the level of environmental performance it sets for itself. The actual level of performance depends on economic, regulatory, and other circumstances.

## SECTION 2: COMPANY PROFILE AND SCOPE

**ENGRO CHEMICAL PAKISTAN LIMITED (ECPL)** is a public limited company incorporated in Pakistan in 1967 under the name of ESSO Pakistan Fertilizer Company Limited (EPFCL). The core business of the company is manufacturing and marketing of Urea fertilizer. The name underwent subsequent changes to EXXON Chemical and from 1991 remains as ENGRO CHEMICAL PAKISTAN LIMITED. The corporate company consists of several divisions : Manufacturing, Marketing , Finance and New joint ventures.


### MANUFACTURING DIVISION

While the Head office is situated at Karachi, the Manufacturing Division is situated at Daharki with appropriate manufacturing facilities, which have been enhanced to produce Urea from 173,000 to over 850,000 Tons per annum through a series of debottlenecking / continuous improvement and expansions in last thirty years. At present, the facility is second largest producer of Urea and holds a 20% share in the local market.

The Division is operating through implementation of defined policies and systems both on production and management sides. The total number of employees are around 500 in the Division. The policies and systems are set for developing not only business and profits but also for employee development and uplifting of community around. Policies and systems are set through documentation of manuals containing procedures of respective departments and further down below units as needed.

### ADDRESS FOR COMMUNICATION

VICE PRESIDENT (MANUFACTURING) ENGRO CHEMICAL PAKISTAN LIMITED DAHARKI- 65020 SINDH	PHONE NO: 92-703- 41001 TO 10 FAX; 92- 703- 41028 & 41029 Web : www. engro.com
---	--

 <b>ECPL Manufacturing Division</b>	<h1>Environmental Management System Manual</h1>	Document No. SET/EMSM/001 Rev. No. 00 Issue No. 01 Effective Date Sep 01, 2003 Page No. Pg 2 of 32 Orig. Prep. by KKn / Sep. 2003
<b>Department: SET</b>	<b>Unit/Section: Env</b>	<b>Area: Environment</b>

## ORGANOGRAM

A detailed organogram is made available in QA / QSP / 01 under reference no. 11.2.

## SCOPE

The purpose of this Manual is to :

- Outline the scope of Environmental Management System at Engro Chemical Pakistan Limited, plant site Daharki.
- Provide a general policy guideline for all its activities pertaining to Environment Management System and implementation of the ISO 14001.

The scope of Environmental Management System (EMS) at ECPL will be limited to Daharki manufacturing site only. The EMS will be applicable to following areas in order of preference:

1. All Plant operating areas.
2. Evaporation ponds.

This EMS Manual is ECPL's level -1 document and refers to level-2 and level-3 documents which describe company procedures, plans and work practices.

## SECTION 3 : DEFINITIONS AND ABBREVIATIONS

### Purpose:

The purpose of this document is to provide the definitions of various terminologies and abbreviations used in this manual.

### Scope:

The scope of this document is limited to liquid effluents of TK-417 and gaseous emissions of SG-621, 631, 641, 25681, HRSG-651, 661, 691, F-2501, Prill tower and waste management within ECPL.

## ISO - 14001 BASIC TERMS AND DEFINITIONS

A key goal of the entire ISO-14001 process is to create a common international language for environmental management. To that end, definitions are critical and have been the subject of lengthy debate in the ISO-14001 development process.


### ORGANIZATION:

Organization is referred to in Clause 3.12 of ISO-14001 as "a company, corporation, operation, firm, enterprise, institution, parts or combinations thereof, whether incorporated or not, public or private that has its own function and administration." If a company is registering to ISO-14001, the actual scope of the registration may apply to a site, a plant, a portion of a site, or several sites that share the same environmental management system. A note to the definition adds the clarification that "for bodies or establishments with more than one operating unit, a single operating unit may be defined as an organization." It's up to the organization, working with the registrar, to define the precise scope of the EMS and the products, processes, services to which it applies.

### ENVIRONMENT:

The environment is defined in ISO-14001 as the surroundings in which an organization operates, including "air, water, land, natural resources, flora, fauna, humans and their interrelation." The environment extends from within the organization to the global system.

From a practical point of view, the environment that concerns a company would be the surroundings in which an organization's activities, products and service have a significant environmental impact and over which the organization can exercise some reasonable control or influence. This influence and control can extend from local, through regional and even to global conditions, depending on the nature of the organization.

 <b>ECPL Manufacturing Division</b>	<b>Environmental Management System Manual</b>	Document No. SET/EMSM/001 Rev. No. 00 Issue No. 01 Effective Date Sep 01, 2003 Page No. Pg 3 of 32 Orig. Prep. by KKn / Sep. 2003
<b>Department: SET</b>	<b>Unit/Section: Env</b>	<b>Area: Environment</b>

### **ENVIRONMENTAL ASPECT:**

An environmental aspect is defined in ISO-14001 as an “element of an organization’s activities, products and/or services which can interact with the environment.” A note to the definition defines a significant environmental aspect as “an environmental aspect which has or can have a significant environmental impact.” It’s up to the organization to identify the environmental aspects of its products, process and services when setting up an EMS.

### **ENVIRONMENTAL IMPACT:**

An environmental impact is “any change to the environment, whether adverse or beneficial, wholly or partially resulting from an organization’s activities, products and/or services”. The environmental aspects of an organization’s activities create environmental impacts.

### **ENVIRONMENTAL MANAGEMENT SYSTEM:**

An environmental management system is “that part of the overall management system which includes organizational structure, planning activities, responsibilities, practices, procedures, processes and resources for developing, implementing, achieving, reviewing and maintaining the environmental policy”.

### **ENVIRONMENTAL MANAGEMENT SYSTEM AUDIT:**

This is a “systematic and documented verification process to objectively obtain and evaluate evidence to determine whether an organization’s environmental management system conforms to the environmental management system audit criteria” that are set by the organization itself. The definition also adds that the results of the EMS audit process must be communicated to management.

### **ENVIRONMENTAL PERFORMANCE:**

Environmental performance refers to “measurable results of the environmental management system, related to an organization’s control of the environmental aspects based on its environmental policy, objectives and targets.”

### **CONTINUAL IMPROVEMENT:**

Continual improvement refers to the “process of enhancing the environmental management system to achieve improvements in overall environmental performance in line with the organization’s policy.” A note adds that “the process need not take place in all areas of activity simultaneously.”

### **ENVIRONMENTAL PLANNING**

Identifying and determining the environmental impacts of organization’s activities, maintaining access to legal requirements, establish targets and EMS.

### **DEFINITION FROM NEQS LEGISLATION**

#### **POLLUTION**


The contamination of air, land or water by the discharge or emission of effluents or wastes or air pollutants or noise or other matter which either directly or indirectly or in combination with other discharges or substance alters unfavorably the properties of air, water and land.

#### **REGULATION**

Regulations made under the NEQS ordinance.

#### **POLLUTION CHARGE**


The industry not complying with the NEQS limits will be required to pay a certain amount of “pollution charge” to the federal EPA. The formula for calculation of this pollution charge will be based on the number of pollution units an industry accumulates.

 <b>ECPL Manufacturing Division</b>	<h1>Environmental Management System Manual</h1>	Document No. SET/EMSM/001 Rev. No. 00 Issue No. 01 Effective Date Sep 01, 2003 Page No. Pg 4 of 32 Orig. Prep. by KKn / Sep. 2003
<b>Department: SET</b>	<b>Unit/Section: Env</b>	<b>Area: Environment</b>

## ABBREVIATIONS:

ADM(D)	Administration Manager (Daharki)
AM2	Ammonia Unit no.2
BMR	Betterment , Modernisation and Revamp
B&E	Business and Economics
DIS	Draft International Standard 9004 : 2000
DQM	Divisional Quality Manual
ECPL	Engro Chemical Pakistan Limited
I / E M	Instrument and Electrical Manager
IR	Industrial Relation
IS	Information Systems
LOAM	Limits of Authority Manual
MFDV	Manufacturing Division, Daharki includes all departments
Mkt	Marketing (Division)
MM	Maintenance Manager
MPT	Management, Professional & Technical (Engineer/ Supervisor /Officer)
MSDS	Material Safety Data Sheets
MTS	Mechanical Technical Services
NC	Non- Conformance
NEQS	National Environment Quality Standards
NMPT	Non Management Professional & Technical person ( Technician / Assistant )
OHIH	Occupational Health and Industrial Hygiene
OS	Office Services
PA	Purchasing Adviser (Karachi)
PA & S	Public Affairs and Services Section (Daharki)
P & D	Planning and Distribution Department (Marketing Division )
PM&S	Product Movement, and Storage
P & IR	Personnel & Industrial Relation unit
PQ	Product Quality
QCC	Quality Council Committee
QMR	Quality Management Representative
QMS	Quality Management System
RCC	Rear Control Center
QSP	Quality System Procedures
S / H	Section Head
SOC	Safe Operations Committee
SIC	Shift Incharge
SOP	Standard Operating Procedures
SETM	Safety, Environment, Industrial Hygiene, Quality & Training Manager
SMP	Safety Management Practices
TM	Technical Manager
UM	Unit Manager
UTY 1 / 2	Utilities Area (either 1 or 2 )
UR 1 / 2	Urea (either 1 or 2)
URUT	Urea and Utilities ( Unit -1)
VPM	Vice President (Manufacturing )
WHSE	Ware house
WI	Work Instructions

Any other abbreviation used in this manual or system procedures is listed down in the respective procedure as and when used

 <b>ECPL Manufacturing Division</b>	<b>Environmental Management System Manual</b>	Document No. SET/EMSM/001 Rev. No. 00 Issue No. 01 Effective Date Sep 01, 2003 Page No. Pg 1 of 32 Orig. Prep. by KKn / Sep. 2003
<b>Department: SET</b>	<b>Unit/Section: Env</b>	<b>Area: Environment</b>

## **SECTION 4 : ENVIRONMENTAL MANAGEMENT SYSTEM REQUIREMENTS**

### **4.1 GENERAL REQUIREMENTS**

Manufacturing Division of ECPL has established and maintained an Environmental Management System, the requirements of which are described in the whole of clause 4.

### **4.2 ENVIRONMENTAL POLICY**

#### **SAFETY, SAFETY AND ENVIRONMENT POLICY**

**To be recognized as a world class performer in the field of Health, Safety & Environmental Management**

**Engro will:**

- 1. Conduct its business in a manner that protects the health and safety of employees, contractors, others involved in our operations and the community in which we operate.**
- 2. Continuously improve environmental performance to achieve sustainable development.**
- 3. Strengthen its business by making Health, Safety & Environment (HSE) considerations an integral part of all business activities.**
- 4. Comply with all laws & regulations.**
- 5. Practice transparent public reporting of the HSE performance.**
- 6. Ensure that HSE is a major responsibility of appropriately trained, empowered & accountable employees & management.**
- 7. Promote a culture of learning & practicing HSE management among employees and contractors.**
- 8. Encourage off the Job HSE awareness among employees and families.**


**To achieve these objectives, Engro Shall:**

#### **Health**

- 1. Identify and evaluate health risks related to its operations that potentially affect its employees, contractors or the public.**
- 2. Implement programs and appropriate protective measures to control such risks, including appropriate monitoring of its potentially affected employees. Carry out pre-employment and periodic medical check-up of its employees.**
- 3. Provide or arrange for medical services necessary for the treatment of employee occupational illness or injuries and for handling medical emergencies.**

#### **Safety**


- 1. Implement a rigorous system of Process Safety Risk Management**
- 2. Institutionalize behavioral safety practices using the Personnel Safety Management system.**
- 3. Keep abreast of the latest international codes, standards and practices and adopting the same where applicable.**

 <b>ECPL Manufacturing Division</b>	<b>Environmental Management System Manual</b>	Document No. SET/EMSM/001 Rev. No. 00 Issue No. 01 Effective Date Sep 01, 2003 Page No. Pg 2 of 32 Orig. Prep. by KKn / Sep. 2003
<b>Department: SET</b>	<b>Unit/Section: Env</b>	<b>Area: Environment</b>

**Environment**

1. **Comply with all applicable environmental laws, regulations and apply responsible standards where law and regulations does not exist.**
2. **Conserve natural resources & energy by continuously improving our processes and measuring performance.**
3. **Continuously improve our processes to minimize pollution and waste.**

**Signed by :** \_\_\_\_\_ **.Date :** \_\_\_\_\_.

 <b>ECPL Manufacturing Division</b>	<b>Environmental Management System Manual</b>	Document No. SET/EMSM/001 Rev. No. 00 Issue No. 01 Effective Date Sep 01, 2003 Page No. Pg 1 of 32 Orig. Prep. by KKn / Sep. 2003
<b>Department: SET</b>	<b>Unit/Section: Env</b>	<b>Area: Environment</b>

## SECTION 4.3 : PLANNING

### **Purpose:**

The purpose of this document is to provide the details of planning in order to achieve the environmental objectives of Engro.

### **PLANNING:**

The planning phase has five basic steps:

1. Identify environmental aspects of the organization's activities, products and services that it can control and influence.
2. Determine which are associated with significant environmental impacts.
3. Identify and maintain access to legal and all other requirements that apply to the environmental aspects of the activities, products and services.
4. Establish objectives and targets.
5. Establish the Environmental Management Programs.

### **4.3.1 ENVIRONMENTAL ASPECTS**

#### **Purpose:**

The purpose of this document is to cover the environmental aspects due to operations of the manufacturing division of ECPL.

#### **ENVIRONMENTAL ASPECTS:**

The key environmental aspects of urea fertilizer manufacturing are :

#### **AIR EMISSIONS:**

1. Ammonia emissions
2. Urea dust emissions
3. Combustion by products e.g. CO, CO<sub>2</sub>, NO<sub>x</sub>, SO<sub>x</sub>
4. Chlorine emissions
5. Vehicle emissions

#### **LIQUID EFFLUENTS**


1. Effluent to canal
2. Effluent to evaporation ponds
3. Effluent of off-site clarifier sludge to canal

#### **SOLID WASTE**

1. Spent catalyst
2. Lime sludge
3. Chromium sludge
4. Food and paper waste
5. Coating Earth

#### **USE OF NATURAL RESOURCES AND ENERGY**

1. Water
2. Natural gas
3. Electricity

 <b>ECPL Manufacturing Division</b>	<h1>Environmental Management System Manual</h1>	Document No. SET/EMSM/001 Rev. No. 00 Issue No. 01 Effective Date Sep 01, 2003 Page No. Pg 2 of 32 Orig. Prep. by KKn / Sep. 2003
<b>Department: SET</b>	<b>Unit/Section: Env</b>	<b>Area: Environment</b>

## EMERGENCY CONDITIONS AND NOISE GENERATION

The anticipated emergencies of ammonia and chlorine release have been addressed in detail separately in the Emergency Response Manual.

The high noise areas within plant site are identified through periodic surveys of Noise, carried out by OH&IH section which also recommends the use of PPEs (ear plugs & earmuffs) in such areas. Other potential noise generation from plant equipments include the popping action of process PSVs, rupture discs, and during other plant upset/shutdown conditions.

## SYSTEM FOR IDENTIFICATION OF ENVIRONMENTAL ASPECTS

- Identification process of environmental aspects and their impacts includes self examination, observation, results of measurement and monitoring, feedback from previous incidents investigation etc. (Ref : EMSP/SOP/04)
- The significance of environmental aspects are evaluated by filling information in the "Environmental Aspect Evaluation" worksheet, provided with a formula to process the given information and generate a figure for the overall significant impact of a particular process/activity. (Ref : EMSP/SOP/04).
- No change in the plant equipment is done without proper reviews and authorization. The reviewing and authorizing bodies are SOC, Sub-SOC (P), (I&E), (M).
- As part of the reviews, the Sub-SOC(P) also considers the environmental aspects of that change/modification.
- All new projects undergo an Environmental Impact Assessment (EIA) before getting authorization from the government.

The significant aspects and their impacts are considered while setting environmental objectives and appropriate controls are ensured so that employees, the public and the environment are protected.

The responsibility and the methodology for determining environmental aspects is defined in a documented procedure no: EMSP/SOP/04.

**Ref. Procedure:** EMSP/SOP/04.

### 4.3.2 LEGAL AND OTHER REQUIREMENTS

#### **Purpose:**

The purpose of this document is to identify and to have access to the legal requirements, that are applicable to the environmental aspects of ECPL's activities.


ECPL is committed to comply with legal and other requirements that are applicable to the environmental aspects of its activities, i.e. process and operation.

The regulatory and other requirements include :

- Pakistan Environmental Protection Act No. XXXIV of 1997.
- National Environmental Quality Standards (NEQS)
- Guidelines and codes.

#### **Ref Procedure:**

Legal Requirements Procedure - EMSP/SOP/07.

 <b>ECPL Manufacturing Division</b>	<b>Environmental Management System Manual</b>	Document No. SET/EMSM/001 Rev. No. 00 Issue No. 01 Effective Date Sep 01, 2003 Page No. Pg 3 of 32 Orig. Prep. by KKn / Sep. 2003
<b>Department: SET</b>	<b>Unit/Section: Env</b>	<b>Area: Environment</b>

#### 4.3.3 ENVIRONMENTAL OBJECTIVES AND TARGETS

**Purpose:**

The purpose of this document is to establish and maintain documented environmental objectives and targets , at each relevant function and level within ECPL.

While setting environmental objectives and target, consideration will be given to the following:

1. Legal and other requirements
2. Results of significant environmental aspects assessment
3. Technological options
4. Financial, operational and business requirement
5. Views of interested parties

The objective and targets should be consistent with the environmental policy, including the commitment to prevention of pollution.

**Reference:**

APPENDIX-A (Environmental Objectives, Targets and Programs)

#### 4.3.4 ENVIRONMENTAL MANAGEMENT PROGRAM

**Purpose:**

The purpose of this document is to provide the environmental management program required to meet the environmental objectives of ECPL.

**ENVIRONMENTAL MANAGEMENT PROGRAM (S):**

ECPL has established and maintained a programme for achieving objectives and targets. The Environmental Management Programme includes:

- Designation of responsibility for achieving objectives & targets at each relevant function & level.
- Providing the means for fulfilling the objectives and targets.
- Designate a time frame within which they will be achieved.

The Environmental Management Program details what must be done, by whom, how and by when. It can be subdivided into individual processes and procedures applicable to sites or facilities within a site.

The means to fulfill the objectives refers to all necessary resources that include people, skills, technology, financial resources and so on.

**Reference:**


APPENDIX-A (Environmental Objectives, Targets and Programs)

#### 4.4 IMPLEMENTATION AND OPERATION

##### 4.4.1 STRUCTURE & RESPONSIBILITY

**Purpose**

The purpose of this document is to define and communicate the roles, responsibility and authorities in order to facilitate effective environmental management within the Manufacturing Division.

 <b>ECPL Manufacturing Division</b>	<h1>Environmental Management System Manual</h1>	Document No. SET/EMSM/001 Rev. No. 00 Issue No. 01 Effective Date Sep 01, 2003 Page No. Pg 4 of 32 Orig. Prep. by KKn / Sep. 2003
<b>Department: SET</b>	<b>Unit/Section: Env</b>	<b>Area: Environment</b>

## STRUCTURE & RESPONSIBILITY

ECPL has defined company organogram (see attachment-1 ). The responsibility and authority for effective functioning of Environmental Management System has been established and documented in Structure and Responsibility Matrix (see attachment -2).

## RESOURCES

ECPL top management identifies and provides resources essential to the implementation and control of the environmental management system. Resources include human resources and specialized skills, technology and financial resources.

## MANAGEMENT REPRESENTATIVE

Top management's forum QCC (Quality Council Committee) chaired by the vice president manufacturing, also constitutes for Environmental Management System. The QCC appoints the management representative, who irrespective of other responsibilities, have defined roles, responsibilities and authority for:

1. Establishing, implementing and maintaining environmental management system in accordance with the requirements of ISO-14001.
2. Reporting on the performance of the environmental management system to top management for review and as a basis for improvement of the environmental system.

Other responsibilities of the management representative includes:

- a. Conducting compliance audits.
- b. Coordination with external auditors for execution of external compliance audits of EMS.

### 4.4.2 TRAINING, AWARENESS AND COMPETENCE

#### Purpose:

The purpose of this document is to provide the training requirements of the organization and individuals who have a role important to the environmental performance.

#### TRAINING, AWARENESS AND COMPETENCE :


ECPL will develop an Environmental training plan for concerned employees of the organization so that they are aware of :

- The importance of conformance with the environment policy and procedures and with the requirements of EMS.
- Significant environmental impact of their work (actual or potential impacts)
- Environmental benefits of improved personal performance
- Their roles and responsibilities
- Importance of conformance with EMS
- Emergency preparedness and response requirements.
- Consequences of violating procedures.

Personnel performing the tasks which can cause significant environmental impacts shall be competent on the basis of appropriate education, training and/or experience.

#### Ref Procedure:

Training Procedure - EMSP/SOP/02.

 <b>ECPL Manufacturing Division</b>	<h1>Environmental Management System Manual</h1>	Document No. SET/EMSM/001 Rev. No. 00 Issue No. 01 Effective Date Sep 01, 2003 Page No. Pg 5 of 32 Orig. Prep. by KKn / Sep. 2003
<b>Department: SET</b>	<b>Unit/Section: Env</b>	<b>Area: Environment</b>

#### 4.4.3 COMMUNICATION

##### Purpose:

The purpose of this document is to provide the details of communication regarding environmental reporting to external bodies/agencies and within ECPL.

##### COMMUNICATION

ECPL has established and maintains a documented procedure for :

1. **Internal communication** between various levels and functions within the organisation.
2. **External Communication** with outside communities and with external agencies like EPA /any Governmental body regarding Environment.

The procedure explains the means of communication regarding policy, objectives, aspects, environmental programmes and the feedback on environmental concerns and suggestion. This includes:

1. LAN / e-mail
2. Safety flyers
3. Bulletin Boards
4. Incident reporting and feedback
5. Safety Talks

##### Ref Procedure:

Communication Procedure - EMSP/SOP/03

#### 4.4.4 ENVIRONMENTAL MANAGEMENT SYSTEM DOCUMENTATION

##### Purpose

The purpose of this document is to define the system for maintaining documentation of Environmental Management System within the Manufacturing Division.

##### ENVIRONMENTAL MANAGEMENT SYSTEM DOCUMENTATION

ECPL has established and maintained all information pertaining to environmental management system in paper and electronic form, to:

- describe the core elements of the management system and their interaction;
- provide direction to related documentation.


To maintain consistency with the Quality Management System, the guidelines provided in QA/QSP/02 (Quality System), will be followed for documentation for Environmental Management System

##### DOCUMENT DESIGN

##### LEVEL - 1 DOCUMENT :

Environmental Management system Manual , states Safety, Environment and Industrial Hygiene policy and describes an outline of the Environmental Management System of the Manufacturing Division. It also provides reference and direction for various procedures and documents related to Environmental Management System.

##### LEVEL - 2 DOCUMENT :

 <b>ECPL Manufacturing Division</b>	<h1>Environmental Management System Manual</h1>	Document No. SET/EMSM/001 Rev. No. 00 Issue No. 01 Effective Date Sep 01, 2003 Page No. Pg 6 of 32 Orig. Prep. by KKn / Sep. 2003
<b>Department: SET</b>	<b>Unit/Section: Env</b>	<b>Area: Environment</b>

Provides detail on various environment related procedures. This includes Environment Management System Procedures and references to other documents and procedures like Emergency Response Manual, QSPs etc.

#### LEVEL - 3 DOCUMENT :

This includes Standard Operating Procedures, Work Instructions, Standing Orders, etc. It also includes external control documents like reference document standards, other standards, catalogues etc. Level-3 documents are also used by supporting functions in ECPL.

#### **4.4.5 DOCUMENT CONTROL**

##### **Purpose**

The purpose of this document is to define a system/procedures for controlling documents required by ISO-14001 to ensure that :

- They can be located
- They are periodically reviewed, revised as necessary and approved for adequacy by authorized personnel
- The current versions of relevant documents are available at all locations where operations essential to the effective functioning of the environmental management are performed.
- Obsolete documents are promptly removed from all points of issue and points of use, or otherwise assured against unintended use
- Any obsolete documents retained for legal and/or knowledge preservation purposes are suitably identified.

The following documents fall under the Document Control system:

- EMS Manual
- EMS Procedures
- Work Instructions
- Role/Responsibilities
- Document Master List

To maintain consistency in document control system within the manufacturing division, the quality system procedure QA/QSP/05 (Document & Data Control) is followed for meeting the requirements of EMS.

##### **Ref Procedure:**

Document and Data Control - QA/QSP/05.


#### **4.4.6 OPERATIONAL CONTROL**

##### **Purpose**

The purpose of this document is to identify and plan those operations and activities including maintenance that are associated with the identified significant environmental aspects in line with the environmental policy, objectives and targets.

##### **OPERATIONAL CONTROL**

ECPL plans and maintain its activities related to its significant environmental aspects to ensure that they are carried out under specified conditions. The planning includes the designation of

 <b>ECPL Manufacturing Division</b>	<h1>Environmental Management System Manual</h1>	Document No. SET/EMSM/001 Rev. No. 00 Issue No. 01 Effective Date Sep 01, 2003 Page No. Pg 7 of 32 Orig. Prep. by KKn / Sep. 2003
<b>Department: SET</b>	<b>Unit/Section: Env</b>	<b>Area: Environment</b>

responsibility of managing the activity, controls and operating procedures. The operations of the facilities are carried out with following operational controls so as to protect the environment :

1. Air emission control
2. Noise control
3. Effluent control
4. Supplier control
5. Solid Waste Management
6. Conservation of Energy and Natural Resources
7. Use and availability of Personnel Protective Equipments (PPEs)
8. Control of Hazardous substances as per MSDS.
9. Maintenance

The detailed instructions covering the strategy and philosophy of plant operation at ECPL are mentioned in the Operating Manual of the independent plants.

#### Ref Procedures:

Operating Manuals of Ammonia-2, Urea-2 and URUT-1 units.

Special Procedures Manual of Ammonia-2, Urea-2 and URUT-1 units.

Handling and Storage in Warehouse	QA/QSP/15 (section 5.6)
Safety Manual	(SAF/MAN/002)
Air Emission Control Procedure	(EMSP/SOP/10)
Noise Control Procedure	(OH&IH/SOP/3)
Waste Management Procedure	(EMSP/SOP/05)
Supplier Control Procedure	(EMSP/SOP/11)
Conservation of Energy and Natural Resources	(EMSP/SOP/13)

#### 4.4.7 EMERGENCY PREPAREDNESS AND RESPONSE

##### Purpose


The purpose of this document is to provide the details of emergency preparedness and response in case of potential accidents and emergencies that could cause harm or damage health, safety and environment and to prevent or mitigate associated environmental impacts.

##### EMERGENCY RESPONSE:

Potential emergency situations are identified as follows:

- 1) Ammonia or chlorine leakage or accidental release
- 2) Chemical Spillage
- 3) Fire

{ In the event of release of Ammonia or Chlorine, a well documented procedure exists to handle any such emergency. The details of the procedure are in Emergency Response Manual, copies of which have been placed in all control rooms and other strategic locations.

 <b>ECPL Manufacturing Division</b>	<h1>Environmental Management System Manual</h1>	Document No. SET/EMSM/001 Rev. No. 00 Issue No. 01 Effective Date Sep 01, 2003 Page No. Pg 8 of 32 Orig. Prep. by KKn / Sep. 2003
<b>Department: SET</b>	<b>Unit/Section: Env</b>	<b>Area: Environment</b>

{ All new employees undergo the Safety and Environment orientation and are trained about emergency response and each individual's role statement during an emergency.

{ Regular exercises are also conducted to test the effectiveness of the system from time to time.

The Emergency Response Manual is reviewed and revised as and when necessary, particularly, after the occurrence of accidents or emergency situations.

The emergency procedures are also tested for their adequacy and effectiveness through regular emergency simulation exercises.

**Ref Procedure :**

Emergency Response Manual - SAF/MAN/003.

Spillage Control Procedure (EMSP/SOP/12)

MSDS Manual

**4.5 CHECKING AND CORRECTIVE ACTION**

**4.5.1 MONITORING AND MEASUREMENT**

ECPL has established and well maintained documented procedures for monitoring and measurement of its key operations and activities that can have a significant impact on the environment. The monitoring and measurement is carried out to track performance of the relevant operational controls and conformance with the organisation's environmental objectives and targets.


The monitoring and measurement is carried out as per the Environmental Monitoring Plan (see attached Environmental Monitoring Analyses Schedule). The results of the measuring activities are analyzed to determine the areas of success, continual improvement and to identify activities requiring focus and corrective actions (Ref : EMS/SOP/08).

ECPL has a defined procedure for calibration of the monitoring & measuring equipments. The equipment used for monitoring and measurement purposes are calibrated to ensure the accuracy of the results, as per QA/QSP/11.

ECPL also has established and maintains documented procedure for periodically evaluating compliance with relevant environmental legislation and regulations (Ref: EMS/SOP/01)

**Ref Procedures :**

Functions of Environment Section	EMSP/SOP/01.
Control of Inspection, Measuring & Test equipment	QA/QSP/11.
Laboratory Equipment Calibration Manual	LAB/SOP/10.
Laboratory Analysis Manual	(Utilities unit - LAB/SOP/11)
Laboratory Analysis Manual	( Ammonia unit - LAB/SOP/12)
Laboratory Analysis Manual	(Urea unit - LAB/SOP/13)
Laboratory Warehouse Analysis Manual	(LAB/SOP/14)
Laboratory Fertilizer Analysis Manual	(LAB/SOP/15)
Laboratory Soil Analysis Manual	(LAB/SOP/16)
Laboratory Solutions Manual	(LAB/SOP/17)
Environment Monitoring -Analysis Schedule	

 <p><b>ECPL Manufacturing Division</b></p>	<h1>Environmental Management System Manual</h1>	Document No. SET/EMSM/001 Rev. No. 00 Issue No. 01 Effective Date Sep 01, 2003 Page No. Pg 9 of 32 Orig. Prep. by KKn / Sep. 2003
<b>Department: SET</b>	<b>Unit/Section: Env</b>	<b>Area: Environment</b>

#### 4.5.2 NONCONFORMANCE AND CORRECTIVE AND PREVENTIVE ACTION

ECPL has established and defined the responsibility and authority for handling and investigating nonconformance pertaining to environmental management system, taking action to mitigate any impacts caused and for initiating and completing corrective and preventive action.

ECPL has a documented procedure in place that covers the nonconformance and corrective and preventive actions. Following are the main categories of the environmental nonconformance:

1. Excursions of the NEQS limits
2. Environmental compliants from the surrounding communities.
3. Process Nonconformance.
- 4 Monitoring & Measurement Results.
5. Environmental Management System Audit Findings.

Any corrective or preventive action taken to eliminate the causes of actual and potential nonconformance should be appropriate to the magnitude of problems and commensurate with the environmental impact encountered.

Any changes in the documented procedures resulting from corrective and preventive actions are implemented and recorded accordingly.

#### Ref Procedures :

Nonconformance and Corrective and Preventive Action Procedure - EMSP/SOP/09.

#### 4.5.3 RECORDS

##### Purpose

The purpose of this document is to establish and maintain procedures for the identification, maintenance and disposition of environmental records which includes training records and the results of audits and reviews.

ECPL has established a system of maintaining environmental records whereby the records are legible, identifiable and traceable to the activity, product or service involved. Environmental records are stored and maintained in such a way that they are readily retrievable and protected against damage, deterioration or loss. The retention time for all environmental records is also defined and documented.

##### Ref. Procedure:


Control of Records - QA/QSP/16.

#### 4.5.4 ENVIRONMENTAL MANAGEMENT SYSTEM AUDIT

ECPL has established and maintain programmes and procedures for periodic environmental management system audits to be carried out, in order to :

- a- determine whether or not the environmental management system conforms to planned arrangements and that it has been properly implemented and maintained.
- b- provide information on the results of audits to management.

ECPL has determined the frequency of internal audits for environmental management system to be once per year. Audit plan is initiated by the management representative and approved by the management . The management representative is responsible to ensure the implementation and compliance of the audit plan. The results of internal audit will be communicated to all concerned interfaces, department managers and the ECPL executives.

 <b>ECPL Manufacturing Division</b>	<b>Environmental Management System Manual</b>	Document No. SET/EMSM/001 Rev. No. 00 Issue No. 01 Effective Date Sep 01, 2003 Page No. Pg 10 of 32 Orig. Prep. by KKn / Sep. 2003
<b>Department: SET</b>	<b>Unit/Section: Env</b>	<b>Area: Environment</b>

QA/QSP/17 defines the procedure as well as the responsibilities and requirements for conducting audits and reporting results.

**Ref. Procedure :**

QA/QSP/17.

**4.6 MANAGEMENT REVIEW**

Top management's forum QCC (Quality Council Committee) consists of all department managers, with overall executive responsibility and chaired by the vice president manufacturing, also constitutes for Environmental Management System.

To ensure the continuing suitability, adequacy and effectiveness of the environmental management system, the QCC on monthly basis, except for during plant exigencies, reviews the inputs given by the EMR pertaining to EMS.


EMR ensures that the necessary information is collected to allow management to carry out this evaluation. Records of all the reviews are documented and maintained by EMR.

The management review addresses the possible need for change to policy, objective and other elements of the EMS based on audit results, changing circumstances and the commitment to continual improvement.

Management Reviews include:

1. Results from audits.
2. The extent to which objectives and targets have been met.
3. The continuing suitability of the environmental management system in relation to changing conditions and information
4. Concerns amongst relevant interested parties.
5. Periodic evaluation of compliance to legal and other requirements.

Observations, conclusions and recommendations should be documented for necessary action.

 <b>ECPL Manufacturing Division</b>	<h1>Environmental Management System Manual</h1>	Document No. SET/EMSM/001 Rev. No. 00 Issue No. 01 Effective Date Sep 01, 2003 Page No. Pg 11 of 32 Orig. Prep. by KKn / Sep. 2003
<b>Department: SET</b>	<b>Unit/Section: Env</b>	<b>Area: Environment</b>

## LIST OF ENVIRONMENTAL MANAGEMENT SYSTEM PROCEDURES

S.No.	DESCRIPTION	REF. DOC. NO.
1	Functions of Environment Section (EMS/SOP/01)	EMSP/SOP/01
2	Training Procedure (EMS/SOP/02)	EMSP/SOP/02
3	Communication Procedure	EMSP/SOP/03
4	Identification of Environmental Aspects	EMSP/SOP/04
5	Waste Management Procedure	EMSP/SOP/05
6	Laboratory Waste Management Procedure	EMSP/SOP/06
7	Legal Requirements Procedure	EMSP/SOP/07
8	Monitoring and Measurement Procedure	EMSP/SOP/08
9	Nonconformance and Corrective & Preventive Action Procedure	EMSP/SOP/09
10	Air emission Control Procedure	EMSP/SOP/10
11	Supplier's Goods and Services Procedure	EMSP/SOP/11
12	Spillage Control Procedure	EMSP/OP/12
13	Procedure for Conservation of Energy & Natural Resource	EMSP/SOP/13
14	Guideline For Handling Hazardous Chemicals	SAF/SOP_SM/6.2
15	Safety Manual	SAF/MAN/002
16	Emergency Response Manual	SAF/MAN/003
17	Asbestos Manual	OHIH/ASBMAN/01
18	Laboratory Equipment Calibration Manual	LAB/SOP/10
19	Document & Data Control	QA/QSP/05
20	Control of Inspection, Measuring and Test Equipments	QA/QSP/11
21	Handling, Storage, Packaging, Preservation, and Delivery	QA/QSP/15
22	Control of Records	QA/QSP/16
23	Internal Auditing	QA/QSP/17

## Appendix E: Ambient Noise Modeling

---

The ambient noise modeling was conducted in order to predict the noise levels at sensitive receptors such as any human settlements in the surrounding areas of the plant and assess whether the IFC guidelines would be met.

A baseline noise study was conducted by gathering data at different points both inside and outside the plant. This was followed by an analysis of the predicted noise levels from the proposed project. Lastly, the cumulative effect of the present noise scenario coupled with the proposed project was analyzed to obtain the predicted noise levels at the chosen sensitive receptor locations.

### E.1 Baseline Noise

#### Noise Measurement Points

The noise level measurements were carried out at 91 different locations, both inside and outside the plant boundaries during both day and night times. The results are shown as **Exhibit E.1** and the map showing the noise sampling points is shown as **Exhibit E.2**.

#### Procedure

The baseline noise study was carried out by the HBP team in accordance with the HBP Noise Monitoring Procedure (Ref No: XEP-F03-01). The Type 2 portable sound meter was used.

Prior to the measurement, the instrument was calibrated using noise calibrator unit. Those locations were chosen for noise measurements, both inside and outside the plant which provided reliable results and were most meaningful for the subsequent analysis.

Firstly, before a measurement was taken at a specific point, it was ensured that no background noise existed. The reading was then obtained at each measurement point by holding the Sound Level Meter (SLM) at arm's length until the SLM reading stabilized. Secondly, during the measurement the wind speeds were also monitored to ensure they did not exceed 10 km/hr. Each noise reading was obtained twice and an average calculated to account for any variations.

If while recording the measurement, any disturbance occurred such as traffic noise etc. then it was noted and these readings were subsequently discarded. The noise contour maps obtained for the day and night noise levels are shown as **Exhibit E.3** and **Exhibit E.4** respectively.

#### Sensitive Receptors

The living areas surrounding the noise sources were identified and measurements carried out near these living areas to predict the noise levels in those residential areas once the proposed project becomes operational. The noise readings were carried out both inside as well as outside the wall, both during the day as well as the night to obtain the baseline information.

The purpose of this exercise was to predict the wall attenuation and as a result consider its effect in the noise analysis. The wall attenuation was obtained as the difference between the measured noise levels and those predicted by the contours. The knowledge of the level of attenuation occurring was important to accurately predict the cumulative noise ratings i.e., the noise generated at different points chosen outside the plant boundary once the proposed project had come into operation.

However, only the noise ratings obtained from various locations inside the plant were used to generate the contours. The baseline noise ratings obtained at the different sensitive receptor points at both day and night time are shown as **Exhibit E.5**.

## **E.2 New Sources of Noise**

Two primary noise sources exist which are the urea and ammonia units and they contain further sub-units. The *predicted* noise ratings provided for the different sub-units of the urea and ammonia units are shown as **Exhibit E.6**.

These predicted values were used to calculate the noise ratings being received at each of the points inside the plant from the Urea and ammonia units using noise equations. The noise contour map generated from the expansion project is shown as **Exhibit E.7**.

## **E.3 Cumulative Source of Noise (Existing and New Combined)**

The measurements obtained from the plant site during both day and night times were compared with the noise level data calculated through the generation of contours for areas around the plant which comprise of living areas. The difference between these two data readings was the accentuation resulting from the existence of the boundary wall.

The accentuation was obtained in order to accurately predict the noise level being transmitted across the plant boundary wall, during both day and night times. This is due to the boundary wall acting as a barrier to the sound waves which results in a reduction of the noise transmitted across the wall and into the surroundings. Furthermore, as sound waves strike the boundary wall, some are reflected, thus causing the measuring points within the plant to register higher than actual noise levels while further reducing the noise levels being transmitted across the wall barrier.

Consequently, two factors need to be considered to accurately predict the noise levels transmitted across the plant boundary and into the surroundings. The first, being accentuation has been considered and the second being reflection, has not as there is no method to accurately predict the amount of reflection which might take place.

In this particular situation, there are two boundary walls which double the levels of accentuation as well as reflection of the sound waves taking place as they travel from the source inside the plant to the surroundings. A significant reduction in the predicted noise levels would occur if the reflection phenomenon was accounted for.

As such, the predicted noise levels reported are presented as conservative estimates and the actual noise levels should be lower than those reported here.

The cumulative noise levels of both day and night are shown in **Exhibit E.8**. The noise contour maps for the cumulative day and night are shown as **Exhibit E.9** and **Exhibit E.10** respectively.

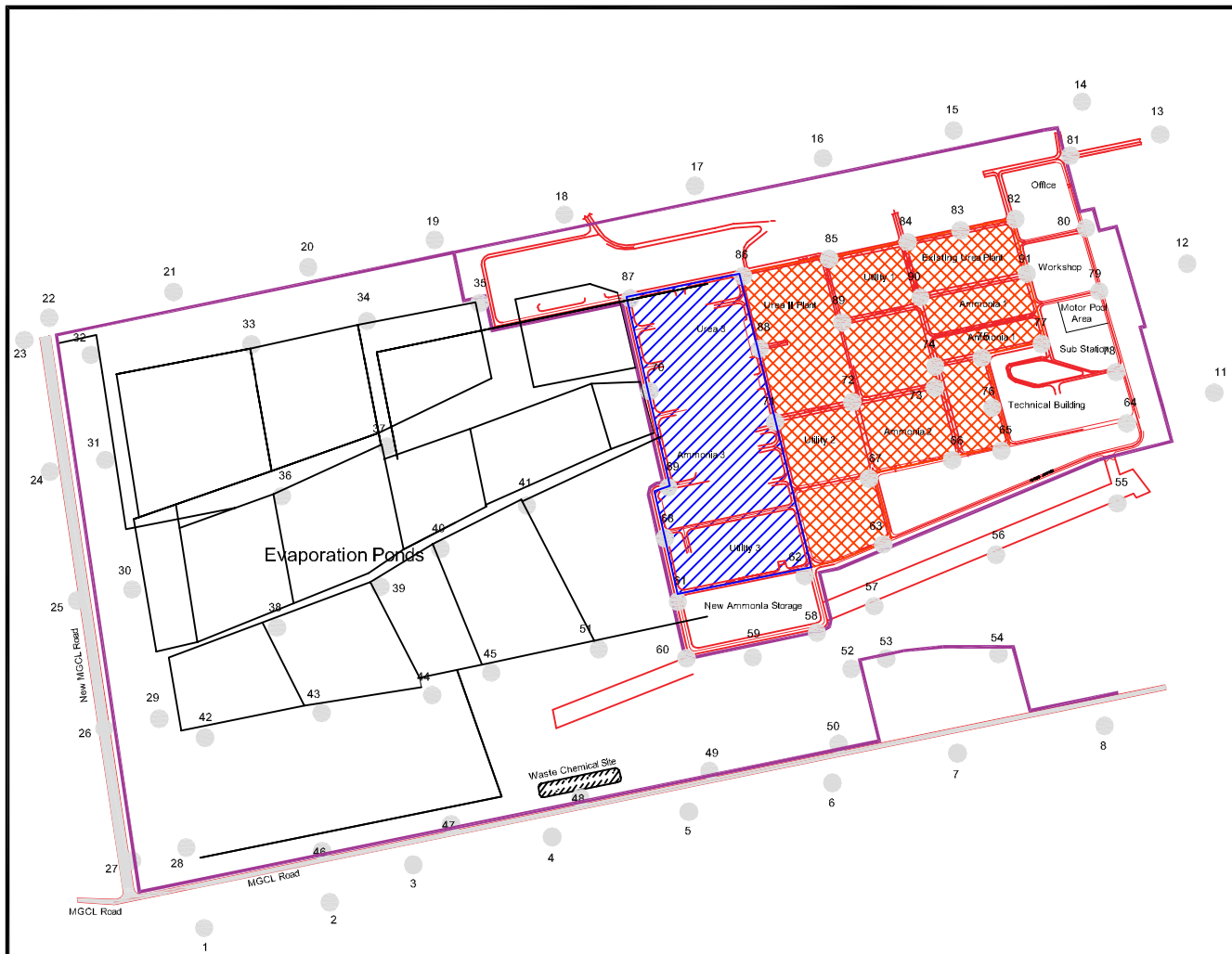
**Exhibit E.1: Detailed Plant Noise Data for Day and Night (dBA)**

<i>Measurement Point</i>	<i>Baseline Night Noise (dBA)</i>	<i>Baseline Day Noise (dBA)</i>
1.	41.5	39.1
2.	47.3	38.6
3.	44.4	35.8
4.	42	38.9
5.	43.1	37.8
6.	46	47.2
7.	51.9	41.6
8.	55.9	–
9.	–	–
10.	54.5	61.4
11.	54.3	58.1
12.	57.1	54.5
13.	54.5	56.8
14.	–	56.2
15.	–	58.1
16.	–	60.3
17.	–	57.6
18.	–	55.3
19.	–	51.4
20.	–	48.1
21.	–	45.6
22.	43.6	–
23.	48.3	44.5
24.	45.6	41.3
25.	46.7	41.8
26.	45.8	37.4
27.	45.5	35.5
28.	–	–
29.	–	–
30.	–	35.5
31.	–	43.8
32.	–	42.3

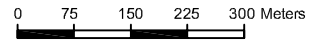
33.	–	45.8
34.	37	47.9
35.	–	50.1
36.	–	52.4
37.	–	–
38.	–	41.8
39.	–	48.1
40.	–	51.6
41.	–	55
42.	–	45.6
43.	–	49.1
44.	–	50.1
45.	–	51.5
46.	–	–
47.	–	–
48.	–	–
49.	–	–
50.	–	–
51.	–	56.7
52.	–	62.2
53.	–	–
54.	–	55.9
55.	57.5	–
56.	61.2	–
57.	75.7	–
58.	56.1	–
59.	–	–
60.	53	–
61.	–	53.2
62.	65.3	64.7
63.	70.1	68.1
64.	64.2	61.5
65.	71.2	68.5
66.	82.3	77.8
67.	70.1	68.3

68.	–	58.9
69.	–	58.2
70.	–	60.4
71.	71.5	71.2
72.	84.2	86
73.	70.8	75.3
74.	71.4	74.2
75.	71.3	70.1
76.	71.5	68.9
77.	66.7	66.6
78.	66.8	61.3
79.	60.4	68.2
80.	63.9	–
81.	59.5	60.1
82.	70.4	67.5
83.	77.5	75.8
84.	72.5	73.1
85.	72.1	70.8
86.	66.1	65.1
87.	63.3	60.4
88.	68.5	66.8
89.	76.2	77.4
90.	70.3	70.7
91.	71.9	–

**Note:** Dash (–) means missing data points which were discarded due to high background noise at the time of the sampling.



- Legend**
- Boundary Wall
  - Proposed Plant
  - Existing Plant
  - Sampling Point  3

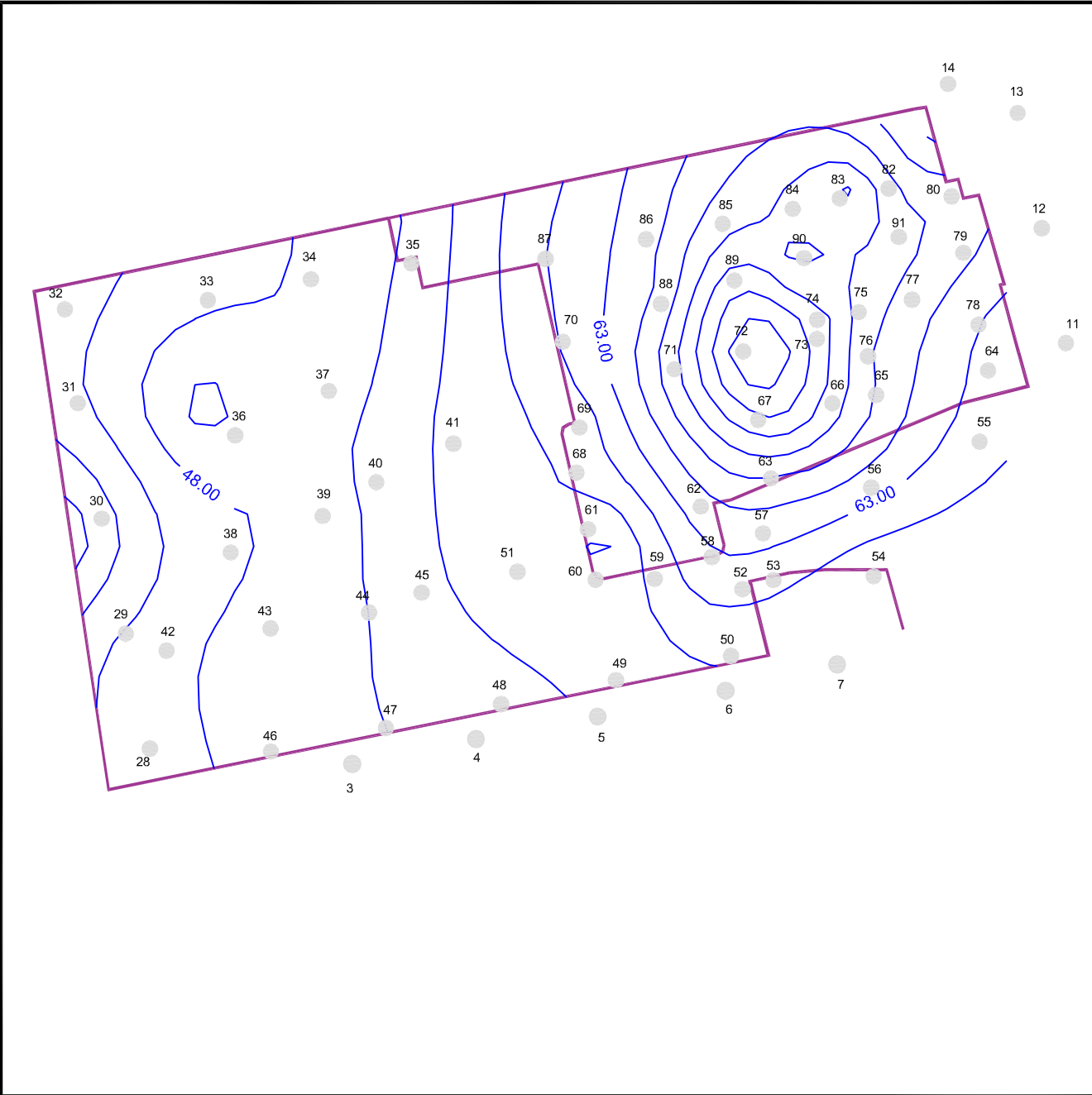





**ECPL Fertilizer Plant Expansion Project**

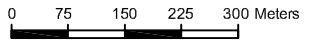
**Exhibit E.2  
Noise Sampling Plan**

<b>Scale</b>	1 : 10,000
<b>Drawing</b>	W7E01DEE
<b>Date</b>	June 2007
<b>Client</b>	Engro Chemical Pakistan Ltd.





- Legend**
- Boundary Wall 
  - Contours 
  - Sampling Points 



**ECPL Fertilizer Plant Expansion Project**

**Exhibit E.3  
Baseline Day Noise**

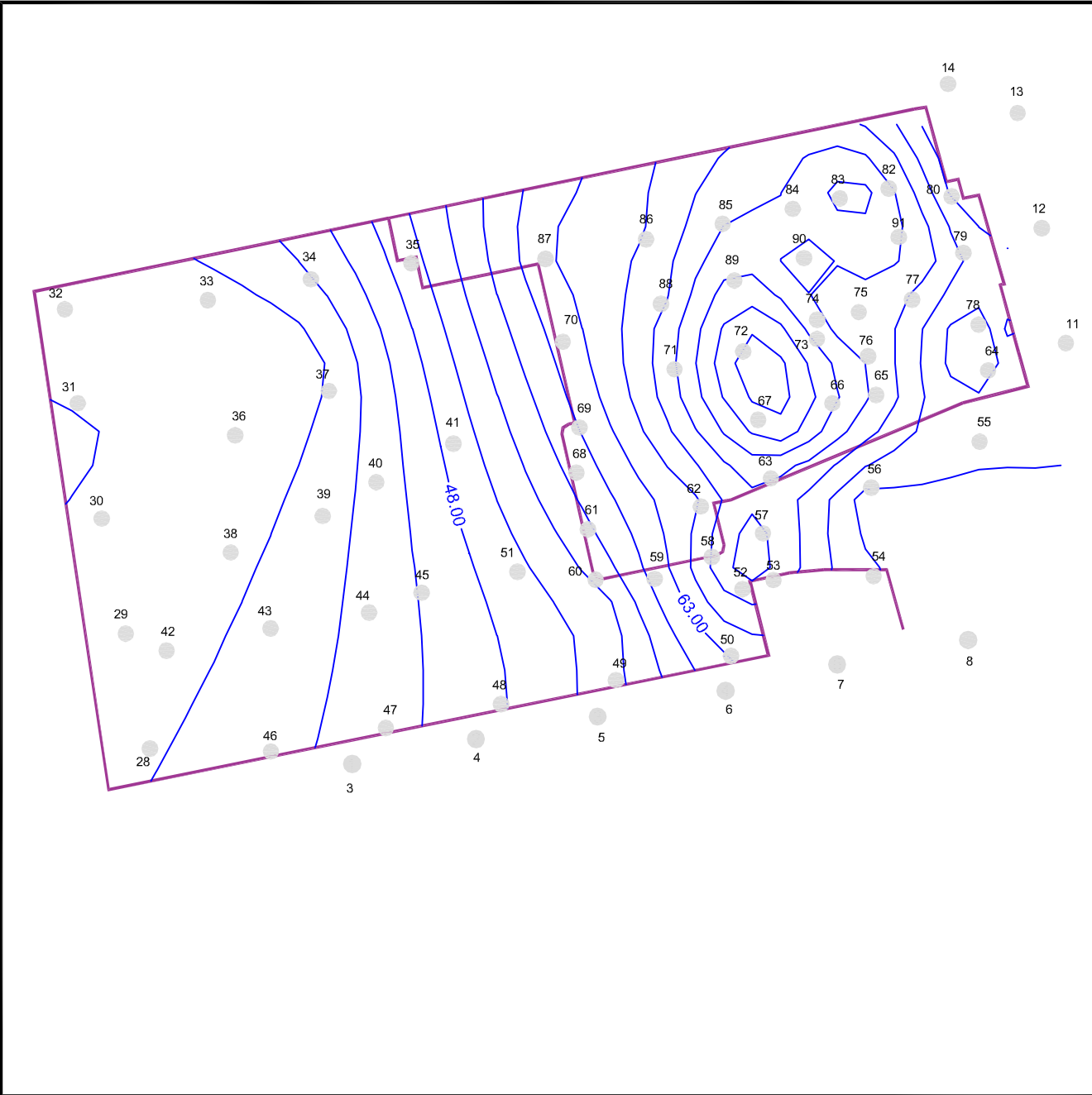
**Scale** 1 : 10,000

**Drawing** W7E02DEE

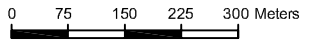
**Date** June 2007

**Client** Engro Chemical Pakistan Ltd.





- Legend**
- Boundary Wall
  - Contours
  - Sampling Points



**ECPL Fertilizer Plant Expansion Project**

**Exhibit E.4  
Baseline Night Noise**

**Scale** 1 : 10,000

**Drawing** W7E03DEE

**Date** June 2007

**Client** Engro Chemical Pakistan Ltd.

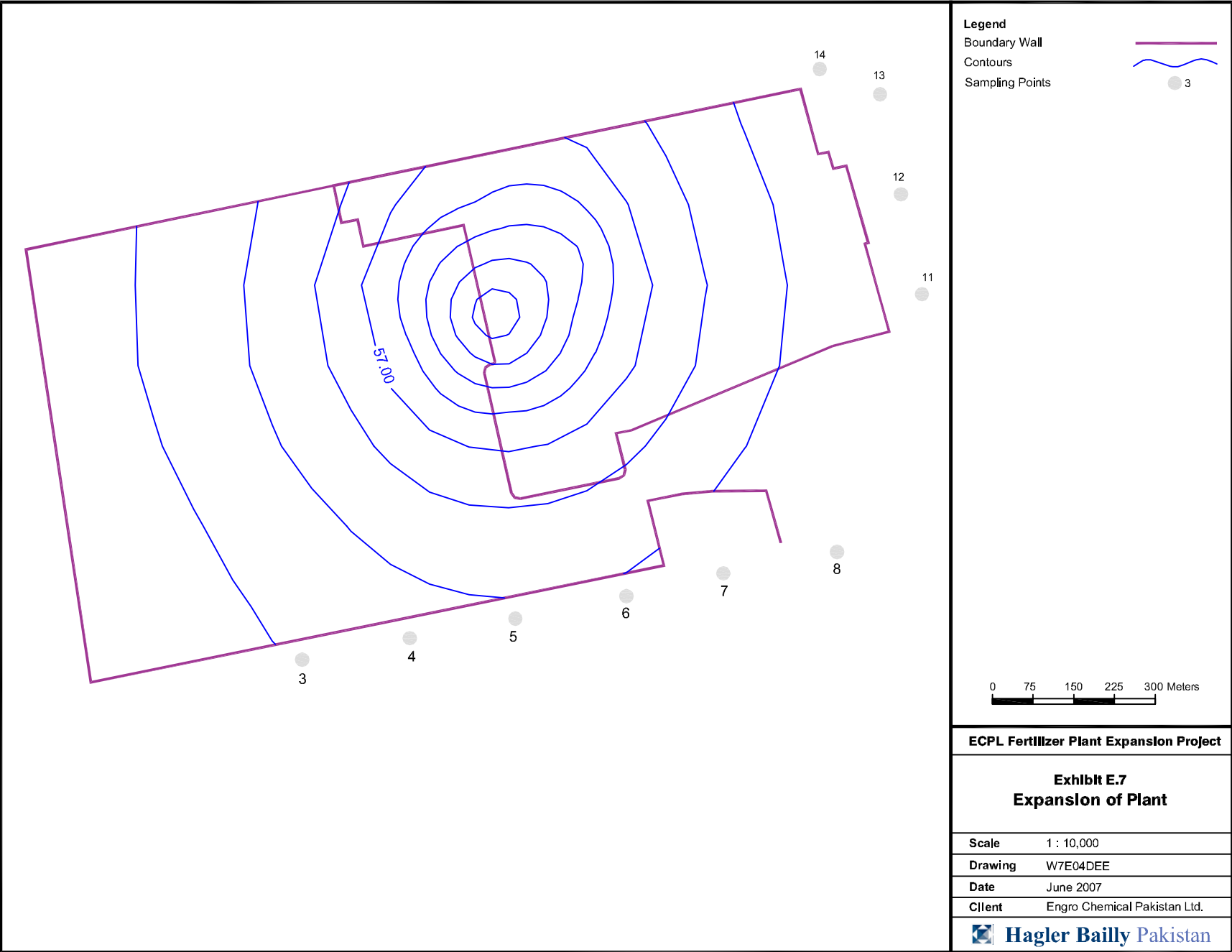


**Exhibit E.5:** Baseline Noise during Day and Night (dBA) at the Receptor

<i>Points</i>	<i>Day Noise (dBA)</i>	<i>Night Noise (dBA)</i>
3	36.3	40.8
4	38.3	43.4
5	40.3	45.9
6	42.3	48.5
7	44.2	51.1
8	–	53.7
10	54.5	61.4
11	54.3	58.1
12	57.1	54.5
13	54.5	56.8

**Exhibit E.6:** Predicted Noise Levels of different equipment (dBA)

<i>Urea Unit</i>	<i>Predicted Noise Levels (at 1 m) (dBA)</i>
Vacuum System	88
Carbamate Ejector	85
H.P. Ammonia Pumps	95
Ammonia Booster Pumps	86
Ammonia Solution Pumps	90
Urea Melt Pumps	90
Steam Condensate Pumps	82
Distillation Tower Feed Pumps	86
Hydrolyser Feed Pumps	87
Process Condensate Pumps	85
HP Stripper Air Compressor	94
<b>Ammonia Unit</b>	
CO2 Compressor	97
Process Air Compressor	99
Recirculation Compressor	99
Condensate Extraction Pump	90
Primary Reformer	90
Flue Gas Blower	87
Solution Pump	95



**Legend**  
 Boundary Wall   
 Contours   
 Sampling Points 

**ECPL Fertilizer Plant Expansion Project**

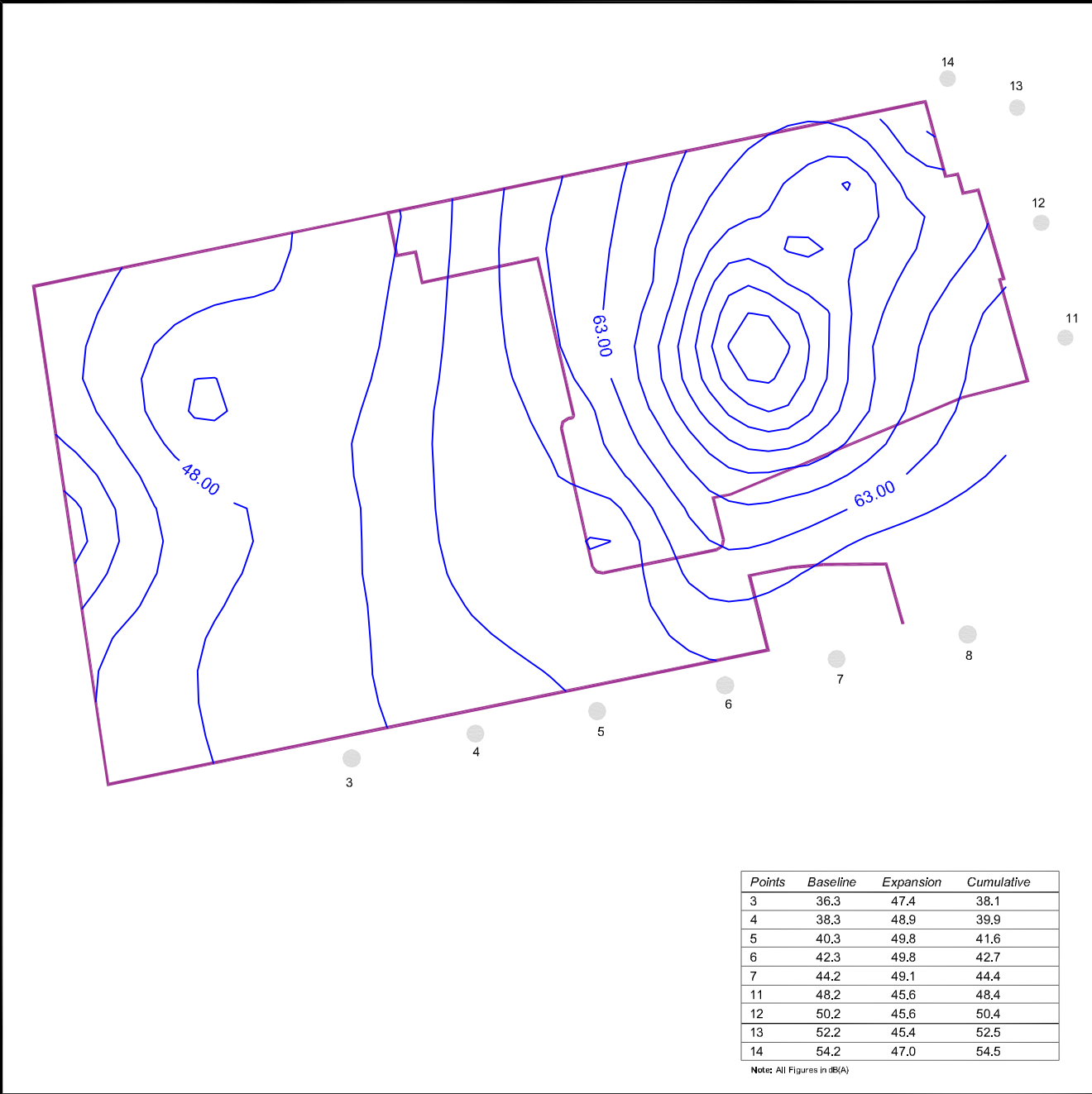
**Exhibit E.7  
 Expansion of Plant**

<b>Scale</b>	1 : 10,000
<b>Drawing</b>	W7E04DEE
<b>Date</b>	June 2007
<b>Client</b>	Engro Chemical Pakistan Ltd.

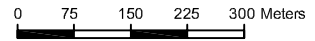


**Exhibit E.8:** Cumulative Noise during Day and Night (dBA) at receptors

<i>Points</i>	<i>Cumulative Noise During Day (dBA)</i>	<i>Cumulative Noise During Night (dBA)</i>
3	38.1	46.4
4	39.9	47.6
5	41.6	47.9
6	42.7	48.8
7	44.4	51.2
8	–	53.8
10	54.7	61.9
11	54.5	58.6
12	57.4	54.9
13	54.8	57.3



- Legend**
- Boundary Wall
  - Contours
  - Sampling Points



Points	Baseline	Expansion	Cumulative
3	36.3	47.4	38.1
4	38.3	48.9	39.9
5	40.3	49.8	41.6
6	42.3	49.8	42.7
7	44.2	49.1	44.4
11	48.2	45.6	48.4
12	50.2	45.6	50.4
13	52.2	45.4	52.5
14	54.2	47.0	54.5

Note: All Figures in dB(A)

**ECPL Fertilizer Plant Expansion Project**

**Exhibit E.9  
Cumulative Day Noise**

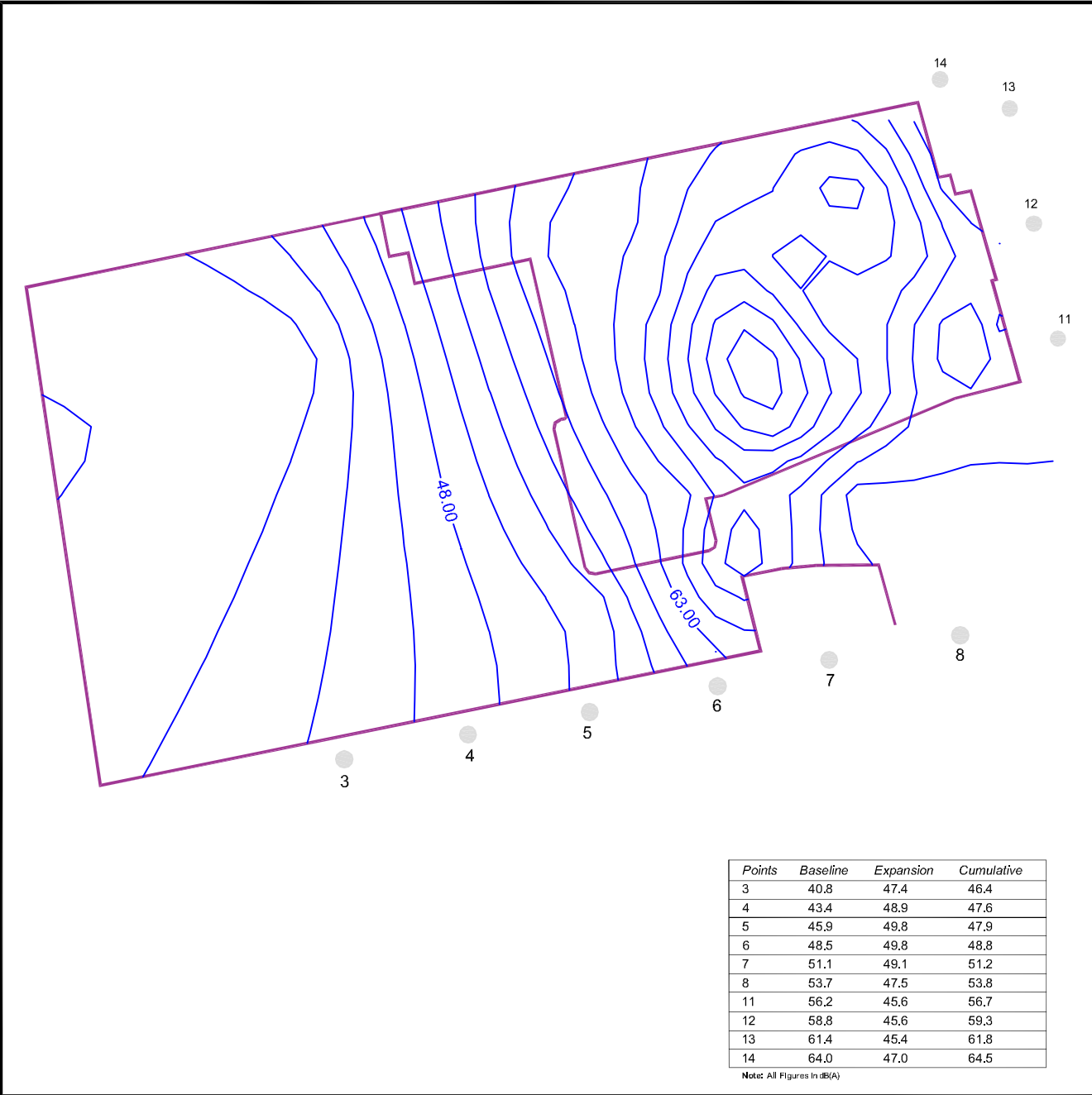
**Scale** 1 : 10,000

**Drawing** W7E05DEE

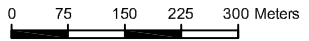
**Date** June 2007

**Client** Engro Chemical Pakistan Ltd.





- Legend**
- Boundary Wall
  - Contours
  - Sampling Points 3



Points	Baseline	Expansion	Cumulative
3	40.8	47.4	46.4
4	43.4	48.9	47.6
5	45.9	49.8	47.9
6	48.5	49.8	48.8
7	51.1	49.1	51.2
8	53.7	47.5	53.8
11	56.2	45.6	56.7
12	58.8	45.6	59.3
13	61.4	45.4	61.8
14	64.0	47.0	64.5

Note: All Figures in dB(A)

**ECPL Fertilizer Plant Expansion Project**

**Exhibit E.10  
Cumulative Night Noise**

**Scale** 1 : 10,000

**Drawing** W7E06DEE

**Date** June 2007

**Client** Engro Chemical Pakistan Ltd.



## Appendix F: Air Dispersion Modeling

---

### F.1 Brief Description of the Model

To model the ambient air concentrations in the area, the widely used Industrial Source Complex Short-Term Air Dispersion Model Version 3 (commonly called ISCST3) was used. This model provides hourly as well as annual averages of pollutants in ambient air and complies with USEPA's guidelines on air quality models. The model has the following features:

- ▶ It is ideal for a typical industrial source complex.
- ▶ It is a steady-state Gaussian plume model that can be used to estimate emission from point, area or volume sources in flat or gently rolling terrain with elevations below emission release height.
- ▶ It incorporates the effects of building downwash, building cavity, settling and dry deposition of pollutants.
- ▶ It can be used to model multiple point source emission from stacks, multiple vents, storage piles and conveyor belts.
- ▶ It uses actual hourly meteorological data to define the conditions for plume rise, transport, and dispersion.
- ▶ It estimates the concentration or deposition value for each source-receptor combination for each hour of input meteorology, and calculates user-selected short-term averages, such as one-hour, three-hour, 24-hour and annual averages.

### F.2 Modeling Operations

To run the ISCST-3 Air dispersion model an input file is to be made which contains all the relevant data inputs.

#### F.2.1 Input Parameters

*Source data:* location, emission rate, physical stack height, stack gas exit velocity, stack inside diameter, and stack gas temperature. Optional inputs include source elevation, building dimensions, particle size distribution with corresponding settling velocities, and surface reflection coefficients.

*Meteorological data:* ISCST requires hourly surface weather data from the preprocessor program RAMMET, which provides hourly stability class, wind direction, wind speed, temperature, and mixing height. For ISCLT, input includes stability wind rose (STAR deck), average afternoon mixing height, average morning mixing height, and average air temperature.

*Receptor data:* coordinates and optional ground elevation for each receptor

A scaled general plot plan of the plant was obtained from EEL showing all the relevant structures, emission points, the plant boundary, orientation to true North and the plant reference point Stack parameters for all emission points used for modeling are shown in **Exhibit F.1**.

Hourly meteorological data for Multan, which has the nearest observatory that records hourly data, was used. (Ideally, actual meteorological data for the site should have been used, but it was not available.) Data for March 1994 to April 1995 was used. It was compared with the data for Multan to verify whether the latter could be used for this study; it was found that the two sets generally tally and data for Multan may be used.

Air quality impacts due to point source(s) are best evaluated by estimating the pollutant concentration at receptors placed outside the plant boundary. Therefore, the receptor grid for the modeling covered a distance of 10 km × 10 km with the stacks as the center. The receptors were placed in a 21 × 21 grid, 500 m apart and at a height of 2 m above ground level.

The ISCST3 can be used to model individual stacks separately or all stacks together (the multiple source option). During this study, the multiple source option was used.

Other model options, that were common in all runs of the model, included:

- ▶ Stack-tip downwash
- ▶ Buoyancy induced dispersion
- ▶ Final plume rise
- ▶ Calm winds processing routines
- ▶ Concentration estimates for sources without any effects of building downwash from surrounding buildings or structures
- ▶ Concentration estimates for sources influenced by building downwash from buildings or structures
- ▶ Rural setting
- ▶ Default rural values for wind profile exponents and vertical potential temperature gradients
- ▶ Missing meteorological data processing routines
- ▶ Multan hourly meteorological data (nearest observatory to EEL recording hourly met data)
- ▶ Flat terrain (no elevated terrain greater than emission height)
- ▶ Multiple sources
- ▶ Receptor array of 21 × 21 receptors.

The following information was collected about the plant and meteorological conditions at the plant site to be used in the input parameters of the model:

- ▶ A plot plan showing: location of all structures and emission points; property line and fence line; orientation to true north; and longitude and latitude of a benchmark
- ▶ Dimensions of all structures in close vicinity of pollutant emitting stacks
- ▶ The following stack details for all emission points:
  - ▷ Stack height (above ground level)
  - ▷ Stack diameter
  - ▷ Stack gas velocity (or flow rate)
  - ▷ Stack gas temperature
- ▶ Maximum short-term and annual emission rates for all pollutants for each stack
- ▶ The following hourly meteorological information:
  - ▷ Wind speed
  - ▷ Wind direction
  - ▷ Cloud ceiling height
  - ▷ Total cloud cover
  - ▷ Cloud opacity
  - ▷ Temperature
  - ▷ Morning and afternoon mixing heights

The input parameters for all the four cases are listed in **Exhibit F.1**.

### **F.2.2 Output Parameters**

Printed output options include:

- ▶ Program control parameters, source data, and receptor data;
- ▶ Tables of hourly meteorological data for each specified day;
- ▶ "N"-day average concentration or total deposition calculated at each receptor for any desired source combinations;
- ▶ Concentration or deposition values calculated for any desired source combinations at all receptors for any specified day or time period within the day;
- ▶ Tables of highest and second highest concentration or deposition values calculated at each receptor for each specified time period during a(n) "N"-day period for any desired source combinations, and tables of the maximum 50 concentration or deposition values calculated for any desired source combinations for each specified time period.

The maximum concentrations for 1, 24, and annual time period were calculated for each pollutant type.

The output files of the ISC 3 model for each of the cases stated in the table above are presented in the following pages.

**Exhibit F.1: Inputs for Air Dispersion Modeling**

<b>Source type (SO<sub>x</sub> and NO<sub>x</sub>)</b>	<b>1+1</b>
Number of stacks	1
Stack height	60.7 m
Stack diameter	1.68 m
Receptor height	2.0 m
Urban/Rural option	Rural
<b>Gas</b>	
Gas flow rate (at stack temperature)	382,765 Nm <sup>3</sup> /hr
Stack Temperature	165 °C
	438 K
Mass emission rate	
Sulfur dioxide	3.72 g/s
Nitrogen oxides	26.58 g/s
<b>Source type (Carbon Monoxide)</b>	<b>1</b>
Number of stacks	<b>1+1+1+1</b>
Stack height	90 m
Stack diameter	0.46 m
Receptor height	2.0 m
Urban/Rural option	Rural
<b>Gas</b>	
Gas flow rate (at stack temperature, E-208 at 50% load )	205,191 Nm <sup>3</sup> /hr
Gas flow rate (at stack temperature, LTSC at 100% load)	410,382 Nm <sup>3</sup> /hr
Gas flow rate (at stack temperature, E-208 at 100% load )	410,382 Nm <sup>3</sup> /hr
Gas flow rate (at stack temperature, Plant Trip IS1)	666,923 Nm <sup>3</sup> /hr
Stack Temperature	138 °C
	411 K
Mass emission rates	
Carbon Monoxide (E-208 at 50% load)	7.09 g/s
Carbon Monoxide ( LTSC at 100% Load)	0.36 g/s
Carbon Monoxide(E-208 at 100% Load)	14.19 g/s
Carbon Monoxide (Plant Trip IS1)	14.18 g/s

```

** To run the example, type:
**
**   ISCST3 TEST-ST.inp  outfil.nam
**
** The results for this example problem are provided in file BDR208.out
** CONTROL OPTIONS
CO STARTING
  TITLEONE  MULTIPLE POINT SOURCE ISCST3 MODEL
  TITLETWO  ENGRO CHEMICALS (DHARAKI) SINDH
  MODELOPT  RURAL  CONC MSGPRO
  AVERTIME  1 24 MONTH PERIOD
  POLLUTID  CO
**   RUNORNOT  NOT
  RUNORNOT  RUN
  TERRHGTS  FLAT
  FLAGPOLE  2
  ERRORFIL  ERRORS.OUT
CO FINISHED
**
** SOURCE OPTIONS
SO STARTING
**   SRCID  SRCTYP      XS      YS      ZS
**   -----
  LOCATION  STACK1  POINT  2318104.9814  1147222.6328  0.0
** Point Source      PTEMIS      STKHGT      STKTMP  STKVEL  STKDIA
** Parameters:      -----
  SRCPARAM  STACK1  7.09      90      411      0.027  0.4572
**   EMISUNIT
  SRCGROUP  ALL
SO FINISHED
** RECEPTOR OPTIONS
RE STARTING
RE GRIDCART PLANT STA
**   Xinit      Xnum  Xdelta      Yinit      Ynum  Ydelta
**   -----
  XYINC  2313104.9814  21  500  1142222.6328  21  500
  GRIDCART PLANT FLAG 1 21*2
  GRIDCART PLANT FLAG 2 21*2
  GRIDCART PLANT FLAG 3 21*2
  GRIDCART PLANT FLAG 4 21*2
  GRIDCART PLANT FLAG 5 21*2
  GRIDCART PLANT FLAG 6 21*2
  GRIDCART PLANT FLAG 7 21*2
  GRIDCART PLANT FLAG 8 21*2
  GRIDCART PLANT FLAG 9 21*2
  GRIDCART PLANT FLAG 10 21*2
  GRIDCART PLANT FLAG 11 21*2
  GRIDCART PLANT FLAG 12 21*2
  GRIDCART PLANT FLAG 13 21*2
  GRIDCART PLANT FLAG 14 21*2
  GRIDCART PLANT FLAG 15 21*2
  GRIDCART PLANT FLAG 16 21*2
  GRIDCART PLANT FLAG 17 21*2
  GRIDCART PLANT FLAG 18 21*2
  GRIDCART PLANT FLAG 19 21*2
  GRIDCART PLANT FLAG 20 21*2
  GRIDCART PLANT FLAG 21 21*2
  GRIDCART PLANT END
RE FINISHED
** MET OPTIONS
ME STARTING
  INPUTFIL  MULTAN2.ASC
  ANEMHGHT  2
  SURFDATA  41675  1994  MULTAN
  UAIRDATA  41675  1994  MULTAN
**   DAYRANGE  1-10
ME FINISHED
OU STARTING
  RECTABLE  ALLAVE  FIRST-SECOND
  MAXTABLE  ALLAVE  50
**   DAYTABLE  ALLAVE

```

```

MAXIFILE 1 ALL 17347.0 MAXIALL.FIL 25
POSTFILE MONTH ALL PLOT PSTMNALL.PLT
POSTFILE 24 ALL PLOT PST24ALL.FIL
POSTFILE PERIOD ALL PLOT PSTPEALL.PLT
PLOTFILE MONTH ALL FIRST PLTMNALL.FIL
PLOTFILE 24 ALL FIRST PLT24ALL.PLT
PLOTFILE 1 ALL FIRST PLT1ALL.PLT
** PLOTFILE PERIOD ALL PLTPEALL.FIL
OU FINISHED
*** SETUP Finishes Successfully ***
*****
*** ISCST3 - VERSION 02035 *** *** MULTIPLE POINT SOURCE ISCST3 MODEL
*** 06/07/07
*** ENGRO CHEMICALS (DHARAKI) SINDH
*** 12:58:21
**MODELOPTs:
PAGE 1
CONC RURAL FLAT FLGPOL MSGPRO
*** MODEL SETUP OPTIONS SUMMARY ***
-----
**Intermediate Terrain Processing is Selected
**Model Is Setup For Calculation of Average CONCENTRATION Values.
-- SCAVENGING/DEPOSITION LOGIC --
**Model Uses NO DRY DEPLETION. DDPLETE = F
**Model Uses NO WET DEPLETION. WDPLETE = F
**NO WET SCAVENGING Data Provided.
**NO GAS DRY DEPOSITION Data Provided.
**Model Does NOT Use GRIDDED TERRAIN Data for Depletion Calculations
**Model Uses RURAL Dispersion.
**Model Uses User-Specified Options:
1. Final Plume Rise.
2. Stack-tip Downwash.
3. Buoyancy-induced Dispersion.
4. Calms Processing Routine.
5. Missing Data Processing Routine.
6. Default Wind Profile Exponents.
7. Default Vertical Potential Temperature Gradients.
**Model Assumes Receptors on FLAT Terrain.
**Model Accepts FLAGPOLE Receptor Heights.
**Model Calculates 3 Short Term Average(s) of: 1-HR 24-HR MONTH
and Calculates PERIOD Averages
**This Run Includes: 1 Source(s); 1 Source Group(s); and 441 Receptor(s)
**The Model Assumes A Pollutant Type of: CO
**Model Set To Continue RUNNING After the Setup Testing.
**Output Options Selected:
Model Outputs Tables of PERIOD Averages by Receptor
Model Outputs Tables of Highest Short Term Values by Receptor (RECTABLE Keyword)
Model Outputs Tables of Overall Maximum Short Term Values (MAXTABLE Keyword)
Model Outputs External File(s) of Threshold Violations (MAXIFILE Keyword)
Model Outputs External File(s) of Concurrent Values for Postprocessing (POSTFILE
Keyword)
Model Outputs External File(s) of High Values for Plotting (PLOTFILE Keyword)
**NOTE: The Following Flags May Appear Following CONC Values: c for Calm Hours
m for Missing Hours
b for Both Calm and
Missing Hours
**Misc. Inputs: Anem. Hgt. (m) = 2.00 ; Decay Coef. = 0.000 ; Rot.
Angle = 0.0
Emission Units = GRAMS/SEC ; Emission
Rate Unit Factor = 0.10000E+07
Output Units = MICROGRAMS/M**3
**Approximate Storage Requirements of Model = 1.3 MB of RAM.
**Input Runstream File: BDR208.inp
**Output Print File: BDR208.out
**Detailed Error/Message File: ERRORS.OUT
*** ISCST3 - VERSION 02035 *** *** MULTIPLE POINT SOURCE ISCST3 MODEL
*** 06/07/07
*** ENGRO CHEMICALS (DHARAKI) SINDH
*** 12:58:21
**MODELOPTs:
PAGE 2

```



1149222.63		2.00	2.00	2.00	2.00	2.00
2.00	2.00	2.00	2.00	2.00	2.00	2.00
1148722.63		2.00	2.00	2.00	2.00	2.00
2.00	2.00	2.00	2.00	2.00	2.00	2.00
1148222.63		2.00	2.00	2.00	2.00	2.00
2.00	2.00	2.00	2.00	2.00	2.00	2.00
1147722.63		2.00	2.00	2.00	2.00	2.00
2.00	2.00	2.00	2.00	2.00	2.00	2.00
1147222.63		2.00	2.00	2.00	2.00	2.00
2.00	2.00	2.00	2.00	2.00	2.00	2.00
1146722.63		2.00	2.00	2.00	2.00	2.00
2.00	2.00	2.00	2.00	2.00	2.00	2.00
1146222.63		2.00	2.00	2.00	2.00	2.00
2.00	2.00	2.00	2.00	2.00	2.00	2.00
1145722.63		2.00	2.00	2.00	2.00	2.00
2.00	2.00	2.00	2.00	2.00	2.00	2.00
1145222.63		2.00	2.00	2.00	2.00	2.00
2.00	2.00	2.00	2.00	2.00	2.00	2.00
1144722.63		2.00	2.00	2.00	2.00	2.00
2.00	2.00	2.00	2.00	2.00	2.00	2.00
1144222.63		2.00	2.00	2.00	2.00	2.00
2.00	2.00	2.00	2.00	2.00	2.00	2.00
1143722.63		2.00	2.00	2.00	2.00	2.00
2.00	2.00	2.00	2.00	2.00	2.00	2.00
1143222.63		2.00	2.00	2.00	2.00	2.00
2.00	2.00	2.00	2.00	2.00	2.00	2.00
1142722.63		2.00	2.00	2.00	2.00	2.00
2.00	2.00	2.00	2.00	2.00	2.00	2.00
1142222.63		2.00	2.00	2.00	2.00	2.00
2.00	2.00	2.00	2.00	2.00	2.00	2.00

\*\*\* ISCST3 - VERSION 02035 \*\*\*      \*\*\* MULTIPLE POINT SOURCE ISCST3 MODEL  
 \*\*\*                    06/07/07

\*\*\* ENGRO CHEMICALS (DHARAKI) SINDH

\*\*\*                    12:58:21

\*\*MODELOPTs:

PAGE        6

CONC

RURAL FLAT    FLGPOL

MSGPRO

\*\*\* NETWORK ID: PLANT        ; NETWORK TYPE: GRIDCART \*\*\*

\* RECEPTOR FLAGPOLE HEIGHTS IN METERS \*

Y-COORD (METERS)		2317605.00	2318105.00	2318605.00	2319105.00	2319605.00
2320105.00		2320605.00	2321105.00	2321605.00		

1152222.63		2.00	2.00	2.00	2.00	2.00
2.00	2.00	2.00	2.00	2.00	2.00	2.00
1151722.63		2.00	2.00	2.00	2.00	2.00
2.00	2.00	2.00	2.00	2.00	2.00	2.00
1151222.63		2.00	2.00	2.00	2.00	2.00
2.00	2.00	2.00	2.00	2.00	2.00	2.00
1150722.63		2.00	2.00	2.00	2.00	2.00
2.00	2.00	2.00	2.00	2.00	2.00	2.00
1150222.63		2.00	2.00	2.00	2.00	2.00
2.00	2.00	2.00	2.00	2.00	2.00	2.00
1149722.63		2.00	2.00	2.00	2.00	2.00
2.00	2.00	2.00	2.00	2.00	2.00	2.00
1149222.63		2.00	2.00	2.00	2.00	2.00
2.00	2.00	2.00	2.00	2.00	2.00	2.00
1148722.63		2.00	2.00	2.00	2.00	2.00
2.00	2.00	2.00	2.00	2.00	2.00	2.00
1148222.63		2.00	2.00	2.00	2.00	2.00
2.00	2.00	2.00	2.00	2.00	2.00	2.00
1147722.63		2.00	2.00	2.00	2.00	2.00
2.00	2.00	2.00	2.00	2.00	2.00	2.00
1147222.63		2.00	2.00	2.00	2.00	2.00
2.00	2.00	2.00	2.00	2.00	2.00	2.00
1146722.63		2.00	2.00	2.00	2.00	2.00
2.00	2.00	2.00	2.00	2.00	2.00	2.00
1146222.63		2.00	2.00	2.00	2.00	2.00
2.00	2.00	2.00	2.00	2.00	2.00	2.00
1145722.63		2.00	2.00	2.00	2.00	2.00
2.00	2.00	2.00	2.00	2.00	2.00	2.00

1145222.63		2.00	2.00	2.00	2.00	2.00
2.00	2.00	2.00	2.00	2.00	2.00	2.00
1144722.63		2.00	2.00	2.00	2.00	2.00
2.00	2.00	2.00	2.00	2.00	2.00	2.00
1144222.63		2.00	2.00	2.00	2.00	2.00
2.00	2.00	2.00	2.00	2.00	2.00	2.00
1143722.63		2.00	2.00	2.00	2.00	2.00
2.00	2.00	2.00	2.00	2.00	2.00	2.00
1143222.63		2.00	2.00	2.00	2.00	2.00
2.00	2.00	2.00	2.00	2.00	2.00	2.00
1142722.63		2.00	2.00	2.00	2.00	2.00
2.00	2.00	2.00	2.00	2.00	2.00	2.00
1142222.63		2.00	2.00	2.00	2.00	2.00
2.00	2.00	2.00	2.00	2.00	2.00	2.00

\*\*\* ISCST3 - VERSION 02035 \*\*\*      \*\*\* MULTIPLE POINT SOURCE ISCST3 MODEL  
 \*\*\* 06/07/07

\*\*\* ENGRO CHEMICALS (DHARAKI) SINDH

\*\*\* 12:58:21

\*\*MODELOPTs:

PAGE 7

CONC

RURAL FLAT FLGPOL

MSGPRO

\*\*\* NETWORK ID: PLANT ; NETWORK TYPE: GRIDCART \*\*\*

\* RECEPTOR FLAGPOLE HEIGHTS IN METERS \*

Y-COORD (METERS)	2322105.00	2322605.00	2323105.00	X-COORD (METERS)
1152222.63	2.00	2.00	2.00	
1151722.63	2.00	2.00	2.00	
1151222.63	2.00	2.00	2.00	
1150722.63	2.00	2.00	2.00	
1150222.63	2.00	2.00	2.00	
1149722.63	2.00	2.00	2.00	
1149222.63	2.00	2.00	2.00	
1148722.63	2.00	2.00	2.00	
1148222.63	2.00	2.00	2.00	
1147722.63	2.00	2.00	2.00	
1147222.63	2.00	2.00	2.00	
1146722.63	2.00	2.00	2.00	
1146222.63	2.00	2.00	2.00	
1145722.63	2.00	2.00	2.00	
1145222.63	2.00	2.00	2.00	
1144722.63	2.00	2.00	2.00	
1144222.63	2.00	2.00	2.00	
1143722.63	2.00	2.00	2.00	
1143222.63	2.00	2.00	2.00	
1142722.63	2.00	2.00	2.00	
1142222.63	2.00	2.00	2.00	

\*\*\* ISCST3 - VERSION 02035 \*\*\*      \*\*\* MULTIPLE POINT SOURCE ISCST3 MODEL  
 \*\*\* 06/07/07

\*\*\* ENGRO CHEMICALS (DHARAKI) SINDH

\*\*\* 12:58:21

\*\*MODELOPTs:

PAGE 8

CONC

RURAL FLAT FLGPOL

MSGPRO

\* SOURCE-RECEPTOR COMBINATIONS FOR WHICH CALCULATIONS MAY NOT BE

PERFORMED \*

LESS THAN 1.0 METER OR 3\*ZLB IN DISTANCE, OR WITHIN OPEN PIT

SOURCE

SOURCE ID	- - RECEPTOR LOCATION - -	DISTANCE (METERS)
	XR (METERS) YR (METERS)	

STACK1	2318105.0 1147222.6	0.00
--------	---------------------	------

\*\*\* ISCST3 - VERSION 02035 \*\*\*      \*\*\* MULTIPLE POINT SOURCE ISCST3 MODEL  
 \*\*\* 06/07/07

\*\*\* ENGRO CHEMICALS (DHARAKI) SINDH

\*\*\* 12:58:21

\*\*MODELOPTs:

PAGE 9

CONC

RURAL FLAT FLGPOL

MSGPRO

\*\*\* METEOROLOGICAL DAYS SELECTED FOR

PROCESSING \*\*\*









```

** To run the example, type:
**   ISCST3 TEST-ST.inp  outfil.nam
** The results for this example problem are provided in file BDRLTSC.out
** CONTROL OPTIONS
CO STARTING
  TITLEONE  MULTIPLE POINT SOURCE ISCST3 MODEL
  TITLETWO  ENGRO CHEMICALS (DHARAKI) SINDH
  MODELOPT  RURAL  CONC MSGPRO
  AVERTIME  1 24 MONTH PERIOD
  POLLUTID  CO
**   RUNORNOT  NOT
  RUNORNOT  RUN
  TERRHGTS  FLAT
  FLAGPOLE  2
  ERRORFIL  ERRORS.OUT
CO FINISHED
** SOURCE OPTIONS
SO STARTING
**           SRCID  SRCTYP           XS           YS           ZS
**           -----  -----  -----  -----  -----
  LOCATION  STACK1  POINT  2318104.9814  1147222.6328  0.0
** Point Source      PTEMIS      STKHGT      STKTMP      STKVEL      STKDIA
** Parameters:      -----  -----  -----  -----  -----
  SRCPARAM  STACK1  0.3565      90          411         0.0013      0.4572
** EMISUNIT
  SRCGROUP  ALL
SO FINISHED
** RECEPTOR OPTIONS
RE STARTING
RE GRIDCART PLANT STA
**           Xinit      Xnum  Xdelta      Yinit      Ynum  Ydelta
**           -----  -----  -----  -----  -----  -----
           XYINC  2313104.9814  21    500      1142222.6328  21    500
  GRIDCART PLANT FLAG 1 21*2
  GRIDCART PLANT FLAG 2 21*2
  GRIDCART PLANT FLAG 3 21*2
  GRIDCART PLANT FLAG 4 21*2
  GRIDCART PLANT FLAG 5 21*2
  GRIDCART PLANT FLAG 6 21*2
  GRIDCART PLANT FLAG 7 21*2
  GRIDCART PLANT FLAG 8 21*2
  GRIDCART PLANT FLAG 9 21*2
  GRIDCART PLANT FLAG 10 21*2
  GRIDCART PLANT FLAG 11 21*2
  GRIDCART PLANT FLAG 12 21*2
  GRIDCART PLANT FLAG 13 21*2
  GRIDCART PLANT FLAG 14 21*2
  GRIDCART PLANT FLAG 15 21*2
  GRIDCART PLANT FLAG 16 21*2
  GRIDCART PLANT FLAG 17 21*2
  GRIDCART PLANT FLAG 18 21*2
  GRIDCART PLANT FLAG 19 21*2
  GRIDCART PLANT FLAG 20 21*2

```

```

GRIDCART PLANT FLAG 21 21*2
GRIDCART PLANT END
RE FINISHED
** MET OPTIONS
ME STARTING
  INPUTFIL  MULTAN2.ASC
  ANEMHGHT  2
  SURFDATA  41675  1994  MULTAN
  UAIRDATA  41675  1994  MULTAN
**   DAYRANGE  1-10
ME FINISHED
OU STARTING
  RECTABLE  ALLAVE  FIRST-SECOND
  MAXTABLE  ALLAVE  50
**   DAYTABLE  ALLAVE
  MAXIFILE  1 ALL  17347.0  MAXIALL.FIL  25
  POSTFILE  MONTH ALL PLOT PSTMNALL.PLT
  POSTFILE  24 ALL PLOT PST24ALL.FIL
  POSTFILE  PERIOD ALL PLOT PSTPEALL.PLT
  PLOTFILE  MONTH ALL FIRST PLTMNALL.FIL
  PLOTFILE  24 ALL FIRST PLT24ALL.PLT
  PLOTFILE  1 ALL FIRST PLT1ALL.PLT
**   PLOTFILE  PERIOD ALL PLTPEALL.FIL
OU FINISHED
*****
*** SETUP Finishes Successfully ***
*****
***   ISCST3  -  VERSION  02035  ***           ***   MULTIPLE  POINT  SOURCE  ISCST3  MODEL
***           06/07/07                                     ***
***           13:08:01                                     ***   ENGRO      CHEMICALS      (DHARAKI)      SINDH
**MODELOPTs:
PAGE  1
CONC          RURAL FLAT  FLGPOL                      MSGPRO
***           MODEL SETUP OPTIONS SUMMARY           ***
-----
**Intermediate Terrain Processing is Selected
**Model Is Setup For Calculation of Average CONCentration Values.
  -- SCAVENGING/DEPOSITION LOGIC --
**Model Uses NO DRY DEPLETION.  DDPLETE = F
**Model Uses NO WET DEPLETION.  WDPLETE = F
**NO WET SCAVENGING Data Provided.
**NO GAS DRY DEPOSITION Data Provided.
**Model Does NOT Use GRIDDED TERRAIN Data for Depletion Calculations
**Model Uses RURAL Dispersion.
**Model Uses User-Specified Options:
  1. Final Plume Rise.
  2. Stack-tip Downwash.
  3. Buoyancy-induced Dispersion.
  4. Calms Processing Routine.
  5. Missing Data Processing Routine.
  6. Default Wind Profile Exponents.
  7. Default Vertical Potential Temperature Gradients.
**Model Assumes Receptors on FLAT Terrain.

```

```

**Model Accepts FLAGPOLE Receptor Heights.
**Model Calculates 3 Short Term Average(s) of: 1-HR 24-HR MONTH
and Calculates PERIOD Averages
**This Run Includes: 1 Source(s); 1 Source Group(s); and 441 Receptor(s)
**The Model Assumes A Pollutant Type of: CO
**Model Set To Continue RUNNING After the Setup Testing.
**Output Options Selected:
    Model Outputs Tables of PERIOD Averages by Receptor
    Model Outputs Tables of Highest Short Term Values by Receptor (RECTABLE Keyword)
    Model Outputs Tables of Overall Maximum Short Term Values (MAXTABLE Keyword)
    Model Outputs External File(s) of Threshold Violations (MAXIFILE Keyword)
    Model Outputs External File(s) of Concurrent Values for Postprocessing (POSTFILE Keyword)
    Model Outputs External File(s) of High Values for Plotting (PLOTFILE Keyword)
**NOTE: The Following Flags May Appear Following CONC Values: c for Calm Hours
                                                m for Missing Hours
                                                b for Both Calm and Missing Hours
**Misc. Inputs: Anem. Hgt. (m) = 2.00 ; Decay Coef. = 0.000 ; Rot. Angle = 0.0
                Emission Units = GRAMS/SEC ; Emission Rate Unit
Factor = 0.10000E+07
                Output Units = MICROGRAMS/M**3
**Approximate Storage Requirements of Model = 1.3 MB of RAM.
**Input Runstream File: BDRLTSC.inp
**Output Print File: BDRLTSC.out
**Detailed Error/Message File: ERRORS.OUT
*** ISCST3 - VERSION 02035 ***          *** MULTIPLE POINT SOURCE ISCST3 MODEL
*** 06/07/07 ***
*** 13:08:01 ***          ENGRO          CHEMICALS          (DHARAKI)          SINDH
**MODELOPTs:
PAGE 2
CONC          RURAL FLAT FLGPOL          MSGPRO
          *** POINT SOURCE DATA ***
          NUMBER EMISSION RATE          BASE          STACK          STACK          STACK          STACK
BUILDING EMISSION RATE
          SOURCE PART. (GRAMS/SEC) X Y ELEV. HEIGHT TEMP. EXIT VEL. DIAMETER
EXISTS SCALAR VARY
          ID CATS. (METERS) (METERS) (METERS) (METERS) (DEG.K) (M/SEC) (METERS)
BY
-----
STACK1 0 0.35650E+00 2318105.0 1147222.6 0.0 90.00 411.00 0.00 0.46
NO
*** ISCST3 - VERSION 02035 ***          *** MULTIPLE POINT SOURCE ISCST3 MODEL
*** 06/07/07 ***
*** 13:08:01 ***          ENGRO          CHEMICALS          (DHARAKI)          SINDH
**MODELOPTs:
PAGE 3
CONC          RURAL FLAT FLGPOL          MSGPRO
          *** SOURCE IDs DEFINING SOURCE GROUPS ***
GROUP ID          SOURCE IDs
ALL          STACK1 ,
*** ISCST3 - VERSION 02035 ***          *** MULTIPLE POINT SOURCE ISCST3 MODEL
*** 06/07/07 ***
*** 13:08:01 ***          ENGRO          CHEMICALS          (DHARAKI)          SINDH
**MODELOPTs:
PAGE 4

```



1145222.63	2.00	2.00	2.00	2.00	2.00	2.00	2.00
2.00	2.00	2.00					
1144722.63	2.00	2.00	2.00	2.00	2.00	2.00	2.00
2.00	2.00	2.00					
1144222.63	2.00	2.00	2.00	2.00	2.00	2.00	2.00
2.00	2.00	2.00					
1143722.63	2.00	2.00	2.00	2.00	2.00	2.00	2.00
2.00	2.00	2.00					
1143222.63	2.00	2.00	2.00	2.00	2.00	2.00	2.00
2.00	2.00	2.00					
1142722.63	2.00	2.00	2.00	2.00	2.00	2.00	2.00
2.00	2.00	2.00					
1142222.63	2.00	2.00	2.00	2.00	2.00	2.00	2.00
2.00	2.00	2.00					

\*\*\* ISCST3 - VERSION 02035 \*\*\* \*\* MULTIPLE POINT SOURCE ISCST3 MODEL  
 \*\*\* 06/07/07

\*\*\* 13:08:01 \*\*\* ENGRO CHEMICALS (DHARAKI) SINDH

\*\*MODELOPTs:  
 PAGE 6

CONC RURAL FLAT FLGPOL MSGPRO  
 \*\*\* NETWORK ID: PLANT ; NETWORK TYPE: GRIDCART \*\*\*  
 \* RECEPTOR FLAGPOLE HEIGHTS IN METERS \*

Y-COORD (METERS)	2317605.00	2318105.00	2318605.00	2319105.00	2319605.00	2320105.00
2320605.00	2321105.00	2321605.00				

1152222.63	2.00	2.00	2.00	2.00	2.00	2.00	2.00
2.00	2.00	2.00					
1151722.63	2.00	2.00	2.00	2.00	2.00	2.00	2.00
2.00	2.00	2.00					
1151222.63	2.00	2.00	2.00	2.00	2.00	2.00	2.00
2.00	2.00	2.00					
1150722.63	2.00	2.00	2.00	2.00	2.00	2.00	2.00
2.00	2.00	2.00					
1150222.63	2.00	2.00	2.00	2.00	2.00	2.00	2.00
2.00	2.00	2.00					
1149722.63	2.00	2.00	2.00	2.00	2.00	2.00	2.00
2.00	2.00	2.00					
1149222.63	2.00	2.00	2.00	2.00	2.00	2.00	2.00
2.00	2.00	2.00					
1148722.63	2.00	2.00	2.00	2.00	2.00	2.00	2.00
2.00	2.00	2.00					
1148222.63	2.00	2.00	2.00	2.00	2.00	2.00	2.00
2.00	2.00	2.00					
1147722.63	2.00	2.00	2.00	2.00	2.00	2.00	2.00
2.00	2.00	2.00					
1147222.63	2.00	2.00	2.00	2.00	2.00	2.00	2.00
2.00	2.00	2.00					
1146722.63	2.00	2.00	2.00	2.00	2.00	2.00	2.00
2.00	2.00	2.00					
1146222.63	2.00	2.00	2.00	2.00	2.00	2.00	2.00
2.00	2.00	2.00					
1145722.63	2.00	2.00	2.00	2.00	2.00	2.00	2.00
2.00	2.00	2.00					
1145222.63	2.00	2.00	2.00	2.00	2.00	2.00	2.00
2.00	2.00	2.00					
1144722.63	2.00	2.00	2.00	2.00	2.00	2.00	2.00
2.00	2.00	2.00					
1144222.63	2.00	2.00	2.00	2.00	2.00	2.00	2.00
2.00	2.00	2.00					

1143722.63	2.00	2.00	2.00	2.00	2.00	2.00	2.00
2.00	2.00	2.00					
1143222.63	2.00	2.00	2.00	2.00	2.00	2.00	2.00
2.00	2.00	2.00					
1142722.63	2.00	2.00	2.00	2.00	2.00	2.00	2.00
2.00	2.00	2.00					
1142222.63	2.00	2.00	2.00	2.00	2.00	2.00	2.00
2.00	2.00	2.00					

\*\*\* ISCST3 - VERSION 02035 \*\*\* \*\* MULTIPLE POINT SOURCE ISCST3 MODEL  
 \*\*\* 06/07/07

\*\*\* 13:08:01 \*\*\* ENGRO CHEMICALS (DHARAKI) SINDH

\*\*MODELOPTs:  
 PAGE 7

CONC RURAL FLAT FLGPOL MSGPRO  
 \*\*\* NETWORK ID: PLANT ; NETWORK TYPE: GRIDCART \*\*\*  
 \* RECEPTOR FLAGPOLE HEIGHTS IN METERS \*

Y-COORD (METERS)	X-COORD (METERS)		
	2322105.00	2322605.00	2323105.00
1152222.63	2.00	2.00	2.00
1151722.63	2.00	2.00	2.00
1151222.63	2.00	2.00	2.00
1150722.63	2.00	2.00	2.00
1150222.63	2.00	2.00	2.00
1149722.63	2.00	2.00	2.00
1149222.63	2.00	2.00	2.00
1148722.63	2.00	2.00	2.00
1148222.63	2.00	2.00	2.00
1147722.63	2.00	2.00	2.00
1147222.63	2.00	2.00	2.00
1146722.63	2.00	2.00	2.00
1146222.63	2.00	2.00	2.00
1145722.63	2.00	2.00	2.00
1145222.63	2.00	2.00	2.00
1144722.63	2.00	2.00	2.00
1144222.63	2.00	2.00	2.00
1143722.63	2.00	2.00	2.00
1143222.63	2.00	2.00	2.00
1142722.63	2.00	2.00	2.00
1142222.63	2.00	2.00	2.00

\*\*\* ISCST3 - VERSION 02035 \*\*\* \*\* MULTIPLE POINT SOURCE ISCST3 MODEL  
 \*\*\* 06/07/07

\*\*\* 13:08:01 \*\*\* ENGRO CHEMICALS (DHARAKI) SINDH

\*\*MODELOPTs:  
 PAGE 8

CONC RURAL FLAT FLGPOL MSGPRO  
 \* SOURCE-RECEPTOR COMBINATIONS FOR WHICH CALCULATIONS MAY NOT BE PERFORMED \*  
 LESS THAN 1.0 METER OR 3\*ZLB IN DISTANCE, OR WITHIN OPEN PIT SOURCE  
 SOURCE - - RECEPTOR LOCATION - - DISTANCE  
 ID XR (METERS) YR (METERS) (METERS)

STACK1	2318105.0	1147222.6	0.00
--------	-----------	-----------	------

\*\*\* ISCST3 - VERSION 02035 \*\*\* \*\* MULTIPLE POINT SOURCE ISCST3 MODEL  
 \*\*\* 06/07/07

\*\*\* 13:08:01 \*\*\* ENGRO CHEMICALS (DHARAKI) SINDH

\*\*MODELOPTs:  
PAGE 9

CONC	RURAL	FLAT	FLGPOL	MSGPRO			
	*** METEOROLOGICAL DAYS SELECTED FOR PROCESSING ***						
	(1=YES; 0=NO)						
1 1 1 1 1 1 1 1 1 1	1 1 1 1 1 1 1 1 1 1	1 1 1 1 1 1 1 1 1 1	1 1 1 1 1 1 1 1 1 1	1 1 1 1 1 1 1 1 1 1	1 1 1 1 1 1 1 1 1 1	1 1 1 1 1 1 1 1 1 1	1
1 1 1 1 1 1 1 1 1 1	1 1 1 1 1 1 1 1 1 1	1 1 1 1 1 1 1 1 1 1	1 1 1 1 1 1 1 1 1 1	1 1 1 1 1 1 1 1 1 1	1 1 1 1 1 1 1 1 1 1	1 1 1 1 1 1 1 1 1 1	1
1 1 1 1 1 1 1 1 1 1	1 1 1 1 1 1 1 1 1 1	1 1 1 1 1 1 1 1 1 1	1 1 1 1 1 1 1 1 1 1	1 1 1 1 1 1 1 1 1 1	1 1 1 1 1 1 1 1 1 1	1 1 1 1 1 1 1 1 1 1	1
1 1 1 1 1 1 1 1 1 1	1 1 1 1 1 1 1 1 1 1	1 1 1 1 1 1 1 1 1 1	1 1 1 1 1 1 1 1 1 1	1 1 1 1 1 1 1 1 1 1	1 1 1 1 1 1 1 1 1 1	1 1 1 1 1 1 1 1 1 1	1
1 1 1 1 1 1 1 1 1 1	1 1 1 1 1 1 1 1 1 1	1 1 1 1 1 1 1 1 1 1	1 1 1 1 1 1 1 1 1 1	1 1 1 1 1 1 1 1 1 1	1 1 1 1 1 1 1 1 1 1	1 1 1 1 1 1 1 1 1 1	1
1 1 1 1 1 1 1 1 1 1	1 1 1 1 1 1 1 1 1 1	1 1 1 1 1 1 1 1 1 1	1 1 1 1 1 1 1 1 1 1	1 1 1 1 1 1 1 1 1 1	1 1 1 1 1 1 1 1 1 1	1 1 1 1 1 1 1 1 1 1	1
1 1 1 1 1 1 1 1 1 1	1 1 1 1 1 1 1 1 1 1	1 1 1 1 1 1 1 1 1 1	1 1 1 1 1 1 1 1 1 1	1 1 1 1 1 1 1 1 1 1	1 1 1 1 1 1 1 1 1 1	1 1 1 1 1 1 1 1 1 1	1
1 1 1 1 1 1 1 1 1 1	1 1 1 1 1 1 1 1 1 1	1 1 1 1 1 1 1 1 1 1	1 1 1 1 1 1 1 1 1 1	1 1 1 1 1 1 1 1 1 1	1 1 1 1 1 1 1 1 1 1	1 1 1 1 1 1 1 1 1 1	1
1 1 1 1 1 1 1 1 1 1	1 1 1 1 1 1 1 1 1 1	1 1 1 1 1 1 1 1 1 1	1 1 1 1 1 1 1 1 1 1	1 1 1 1 1 1 1 1 1 1	1 1 1 1 1 1 1 1 1 1	1 1 1 1 1 1 1 1 1 1	1
1 1 1 1 1 1 1 1 1 1	1 1 1 1 1 1 1 1 1 1	1 1 1 1 1 1 1 1 1 1	1 1 1 1 1 1 1 1 1 1	1 1 1 1 1 1 1 1 1 1	1 1 1 1 1 1 1 1 1 1	1 1 1 1 1 1 1 1 1 1	1

NOTE: METEOROLOGICAL DATA ACTUALLY PROCESSED WILL ALSO DEPEND ON WHAT IS INCLUDED IN THE DATA FILE.

\*\*\* UPPER BOUND OF FIRST THROUGH FIFTH WIND SPEED CATEGORIES \*\*\*  
(METERS/SEC)

1.54, 3.09, 5.14, 8.23, 10.80,

\*\*\* WIND PROFILE EXPONENTS \*\*\*

STABILITY CATEGORY	WIND SPEED CATEGORY				
	1	2	3	4	5
6					
A	.70000E-01	.70000E-01	.70000E-01	.70000E-01	.70000E-
01	.70000E-01	.70000E-01	.70000E-01	.70000E-01	.70000E-
B	.70000E-01	.70000E-01	.70000E-01	.70000E-01	.70000E-
01	.70000E-01	.70000E-01	.70000E-01	.70000E-01	.70000E-
C	.10000E+00	.10000E+00	.10000E+00	.10000E+00	.10000E+00
D	.15000E+00	.15000E+00	.15000E+00	.15000E+00	.15000E+00
E	.35000E+00	.35000E+00	.35000E+00	.35000E+00	.35000E+00
F	.55000E+00	.55000E+00	.55000E+00	.55000E+00	.55000E+00

\*\*\* VERTICAL POTENTIAL TEMPERATURE GRADIENTS \*\*\*

(DEGREES KELVIN PER METER)

STABILITY CATEGORY	WIND SPEED CATEGORY				
	1	2	3	4	5
6					
A	.00000E+00	.00000E+00	.00000E+00	.00000E+00	.00000E+00
B	.00000E+00	.00000E+00	.00000E+00	.00000E+00	.00000E+00
C	.00000E+00	.00000E+00	.00000E+00	.00000E+00	.00000E+00
D	.00000E+00	.00000E+00	.00000E+00	.00000E+00	.00000E+00
E	.20000E-01	.20000E-01	.20000E-01	.20000E-01	.20000E-
01	.20000E-01	.20000E-01	.20000E-01	.20000E-01	.20000E-

01 .35000E-01 F .35000E-01 .35000E-01 .35000E-01 .35000E-01 .35000E-

\*\*\* ISCST3 - VERSION 02035 \*\*\* MULTIPLE POINT SOURCE ISCST3 MODEL  
06/07/07

\*\*\* 13:08:01 \*\*\* ENGRO CHEMICALS (DHARAKI) SINDH

\*\*MODELOPTs:

PAGE 10

CONC RURAL FLAT FLGPOL MSGPRO

\*\*\* THE FIRST 24 HOURS OF METEOROLOGICAL DATA \*\*\*

FILE: MULTAN2.ASC

FORMAT: (4I2,2F9.4,F6.1,I2,2F7.1,f9.4,f10.1,f8.4,i4,f7.2)

SURFACE STATION NO.: 41675 UPPER AIR STATION NO.: 41675

NAME: MULTAN NAME: MULTAN

YEAR: 1994 YEAR: 1994

FLOW SPEED TEMP STAB MIXING HEIGHT (M) USTAR M-O LENGTH Z-0 IPCODE PRATE  
YR MN DY HR VECTOR (M/S) (K) CLASS RURAL URBAN (M/S) (M) (M) (mm/HR)

94	04	01	01	179.0	0.00	290.9	7	824.0	320.0	0.0000	0.0	0.0000	0	0.00
94	04	01	02	179.0	0.00	290.9	7	824.0	320.0	0.0000	0.0	0.0000	0	0.00
94	04	01	03	184.0	0.00	294.3	7	824.0	320.0	0.0000	0.0	0.0000	0	0.00
94	04	01	04	181.0	0.00	299.3	7	824.0	320.0	0.0000	0.0	0.0000	0	0.00
94	04	01	05	179.0	0.00	303.2	7	824.0	320.0	0.0000	0.0	0.0000	0	0.00
94	04	01	06	272.0	1.54	303.7	7	824.0	320.0	0.0000	0.0	0.0000	0	0.00
94	04	01	07	273.0	2.57	305.4	6	88.6	374.2	0.0000	0.0	0.0000	0	0.00
94	04	01	08	272.0	1.54	305.9	5	193.6	438.4	0.0000	0.0	0.0000	0	0.00
94	04	01	09	266.0	1.03	307.0	4	298.7	502.7	0.0000	0.0	0.0000	0	0.00
94	04	01	17	358.0	0.00	297.0	2	824.0	824.0	0.0000	0.0	0.0000	0	0.00
94	04	01	18	2.0	0.00	295.9	3	824.0	824.0	0.0000	0.0	0.0000	0	0.00
94	04	01	19	5.0	0.00	295.9	4	841.5	841.5	0.0000	0.0	0.0000	0	0.00
94	04	01	20	360.0	0.00	295.4	5	875.3	685.3	0.0000	0.0	0.0000	0	0.00
94	04	01	21	2.0	0.00	294.8	6	909.0	594.0	0.0000	0.0	0.0000	0	0.00
94	04	01	22	5.0	0.00	294.3	7	942.8	502.6	0.0000	0.0	0.0000	0	0.00
94	04	01	23	358.0	0.00	294.3	7	976.6	411.3	0.0000	0.0	0.0000	0	0.00
94	04	01	24	5.0	1.54	293.7	7	1010.3	320.0	0.0000	0.0	0.0000	0	0.00

\*\*\* NOTES: STABILITY CLASS 1=A, 2=B, 3=C, 4=D, 5=E AND 6=F.

FLOW VECTOR IS DIRECTION TOWARD WHICH WIND IS BLOWING.

\*\*\* ISCST3 - VERSION 02035 \*\*\* MULTIPLE POINT SOURCE ISCST3 MODEL  
06/07/07

\*\*\* 13:08:01 \*\*\* ENGRO CHEMICALS (DHARAKI) SINDH

\*\*MODELOPTs:

PAGE 11

CONC RURAL FLAT FLGPOL MSGPRO

\*\*\* THE PERIOD ( 9480 HRS) AVERAGE CONCENTRATION VALUES FOR SOURCE

GROUP: ALL \*\*\*

INCLUDING SOURCE(S): STACK1 ,  
\*\*\* NETWORK ID: PLANT ; NETWORK TYPE: GRIDCART \*\*\*  
\*\* CONC OF CO IN MICROGRAMS/M\*\*3

Y-COORD | X-COORD (METERS)  
(METERS) | 2313105.00 2313605.00 2314105.00 2314605.00 2315105.00 2315605.00  
2316105.00 2316605.00 2317105.00

1152222.63 | 0.00769 0.01281 0.01367 0.01000 0.00402 0.00125  
0.00058 0.00130 0.00584



MX W410	3739	METQA	:Flow Vector Out-of-Range.	KURDAT=	94090319
MX W420	3739	METQA	:Wind Speed Out-of-Range.	KURDAT=	94090319
MX W430	3739	METQA	:Ambient Temperature Data Out-of-Range.	KURDAT=	94090319
MX W410	3740	METQA	:Flow Vector Out-of-Range.	KURDAT=	94090320
MX W430	3888	METQA	:Ambient Temperature Data Out-of-Range.	KURDAT=	94090924
MX W410	3889	METQA	:Flow Vector Out-of-Range.	KURDAT=	94091001
MX W420	3889	METQA	:Wind Speed Out-of-Range.	KURDAT=	94091001
MX W430	3889	METQA	:Ambient Temperature Data Out-of-Range.	KURDAT=	94091001
MX W410	3890	METQA	:Flow Vector Out-of-Range.	KURDAT=	94091002
MX W420	3890	METQA	:Wind Speed Out-of-Range.	KURDAT=	94091002
MX W430	3890	METQA	:Ambient Temperature Data Out-of-Range.	KURDAT=	94091002
MX W410	3891	METQA	:Flow Vector Out-of-Range.	KURDAT=	94091003
MX W420	3891	METQA	:Wind Speed Out-of-Range.	KURDAT=	94091003
MX W430	3891	METQA	:Ambient Temperature Data Out-of-Range.	KURDAT=	94091003
MX W410	3892	METQA	:Flow Vector Out-of-Range.	KURDAT=	94091004
MX W420	3892	METQA	:Wind Speed Out-of-Range.	KURDAT=	94091004
MX W430	3892	METQA	:Ambient Temperature Data Out-of-Range.	KURDAT=	94091004
MX W410	3893	METQA	:Flow Vector Out-of-Range.	KURDAT=	94091005
MX W420	3893	METQA	:Wind Speed Out-of-Range.	KURDAT=	94091005
MX W430	3893	METQA	:Ambient Temperature Data Out-of-Range.	KURDAT=	94091005
MX W410	3894	METQA	:Flow Vector Out-of-Range.	KURDAT=	94091006
MX W420	3894	METQA	:Wind Speed Out-of-Range.	KURDAT=	94091006
MX W430	3894	METQA	:Ambient Temperature Data Out-of-Range.	KURDAT=	94091006
MX W410	3895	METQA	:Flow Vector Out-of-Range.	KURDAT=	94091007
MX W420	3895	METQA	:Wind Speed Out-of-Range.	KURDAT=	94091007
MX W430	3895	METQA	:Ambient Temperature Data Out-of-Range.	KURDAT=	94091007
MX W410	3896	METQA	:Flow Vector Out-of-Range.	KURDAT=	94091008
MX W420	3896	METQA	:Wind Speed Out-of-Range.	KURDAT=	94091008
MX W430	3896	METQA	:Ambient Temperature Data Out-of-Range.	KURDAT=	94091008
MX W410	3897	METQA	:Flow Vector Out-of-Range.	KURDAT=	94091009
MX W420	3897	METQA	:Wind Speed Out-of-Range.	KURDAT=	94091009
MX W430	3897	METQA	:Ambient Temperature Data Out-of-Range.	KURDAT=	94091009
MX W410	3898	METQA	:Flow Vector Out-of-Range.	KURDAT=	94091010
MX W420	3898	METQA	:Wind Speed Out-of-Range.	KURDAT=	94091010
MX W430	3898	METQA	:Ambient Temperature Data Out-of-Range.	KURDAT=	94091010
MX W410	3899	METQA	:Flow Vector Out-of-Range.	KURDAT=	94091011
MX W420	3899	METQA	:Wind Speed Out-of-Range.	KURDAT=	94091011
MX W430	3899	METQA	:Ambient Temperature Data Out-of-Range.	KURDAT=	94091011
MX W410	3900	METQA	:Flow Vector Out-of-Range.	KURDAT=	94091012
MX W420	3900	METQA	:Wind Speed Out-of-Range.	KURDAT=	94091012
MX W430	3900	METQA	:Ambient Temperature Data Out-of-Range.	KURDAT=	94091012
MX W410	3901	METQA	:Flow Vector Out-of-Range.	KURDAT=	94091013
MX W420	3901	METQA	:Wind Speed Out-of-Range.	KURDAT=	94091013
MX W430	3901	METQA	:Ambient Temperature Data Out-of-Range.	KURDAT=	94091013
MX W410	3902	METQA	:Flow Vector Out-of-Range.	KURDAT=	94091014
MX W420	3902	METQA	:Wind Speed Out-of-Range.	KURDAT=	94091014
MX W430	3902	METQA	:Ambient Temperature Data Out-of-Range.	KURDAT=	94091014

\*\*\*\*\*  
\*\*\* ISCST3 Finishes Successfully \*\*\*  
\*\*\*\*\*

```

** To run the example, type:

**   ISCST3 TEST-ST.inp  outfil.nam

** The results for this example problem are provided in file BDRTrip.out

** CONTROL OPTIONS

CO STARTING

  TITLEONE  MULTIPLE POINT SOURCE ISCST3 MODEL

  TITLETWO  ENGRO CHEMICALS (DHARAKI) SINDH

  MODELOPT  RURAL  CONC MSGPRO

  AVERTIME  1 24 MONTH PERIOD

  POLLUTID  CO

**   RUNORNOT  NOT

  RUNORNOT  RUN

  TERRHGTS  FLAT

  FLAGPOLE  2

  ERRORFIL  ERRORS.OUT

CO FINISHED

** SOURCE OPTIONS

SO STARTING

**           SRCID  SRCTYP           XS           YS           ZS
**           -----  -
LOCATION  STACK1  POINT  2318104.9814  1147222.6328  0.0
** Point Source      PTEMIS  STKHGT  STKTMP  STKVEL  STKDIA
** Parameters:      -
SRCPARAM  STACK1  14.18   90      411     0.053  0.4572

** EMISUNIT

  SRCGROUP  ALL

SO FINISHED

** RECEPTOR OPTIONS

```

RE STARTING

RE GRIDCART PLANT STA

**		Xinit	Xnum	Xdelta	Yinit	Ynum	Ydelta
**		-----	----	-----	-----	----	-----
	XYINC	2313104.9814	21	500	1142222.6328	21	500

GRIDCART PLANT FLAG 1 21\*2  
GRIDCART PLANT FLAG 2 21\*2  
GRIDCART PLANT FLAG 3 21\*2  
GRIDCART PLANT FLAG 4 21\*2  
GRIDCART PLANT FLAG 5 21\*2  
GRIDCART PLANT FLAG 6 21\*2  
GRIDCART PLANT FLAG 7 21\*2  
GRIDCART PLANT FLAG 8 21\*2  
GRIDCART PLANT FLAG 9 21\*2  
GRIDCART PLANT FLAG 10 21\*2  
GRIDCART PLANT FLAG 11 21\*2  
GRIDCART PLANT FLAG 12 21\*2  
GRIDCART PLANT FLAG 13 21\*2  
GRIDCART PLANT FLAG 14 21\*2  
GRIDCART PLANT FLAG 15 21\*2  
GRIDCART PLANT FLAG 16 21\*2  
GRIDCART PLANT FLAG 17 21\*2  
GRIDCART PLANT FLAG 18 21\*2  
GRIDCART PLANT FLAG 19 21\*2  
GRIDCART PLANT FLAG 20 21\*2  
GRIDCART PLANT FLAG 21 21\*2  
GRIDCART PLANT END

RE FINISHED

\*\* MET OPTIONS

ME STARTING

INPUTFIL MULTAN2.ASC

ANEMHGHT 2

SURFDATA 41675 1994 MULTAN

UAIRDATA 41675 1994 MULTAN

\*\* DAYRANGE 1-10

ME FINISHED

OU STARTING

RECTABLE ALLAVE FIRST-SECOND

MAXTABLE ALLAVE 50

\*\* DAYTABLE ALLAVE

MAXIFILE 1 ALL 17347.0 MAXIALL.FIL 25

POSTFILE MONTH ALL PLOT PSTMNALL.PLT

POSTFILE 24 ALL PLOT PST24ALL.FIL

POSTFILE PERIOD ALL PLOT PSTPEALL.PLT

PLOTFILE MONTH ALL FIRST PLTMNALL.FIL

PLOTFILE 24 ALL FIRST PLT24ALL.PLT

PLOTFILE 1 ALL FIRST PLT1ALL.PLT

\*\* PLOTFILE PERIOD ALL PLTPEALL.FIL

OU FINISHED

\*\*\*\*\*

\*\*\* SETUP Finishes Successfully \*\*\*

\*\*\*\*\*

\*\*\* ISCST3 - VERSION 02035 \*\*\* \*\* MULTIPLE POINT SOURCE ISCST3 MODEL  
\*\*\* 06/07/07

\*\*\* ENGRO CHEMICALS (DHARAKI) SINDH

\*\*\* 13:50:46



\*\*The Model Assumes A Pollutant Type of: CO

\*\*Model Set To Continue RUNNING After the Setup Testing.

\*\*Output Options Selected:

Model Outputs Tables of PERIOD Averages by Receptor

Model Outputs Tables of Highest Short Term Values by Receptor (RECTABLE  
Keyword)

Model Outputs Tables of Overall Maximum Short Term Values (MAXTABLE  
Keyword)

Model Outputs External File(s) of Threshold Violations (MAXIFILE  
Keyword)

Model Outputs External File(s) of Concurrent Values for Postprocessing  
(POSTFILE Keyword)

Model Outputs External File(s) of High Values for Plotting (PLOTFILE  
Keyword)

\*\*NOTE: The Following Flags May Appear Following CONC Values: c for Calm Hours  
m for Missing  
Hours

b for Both Calm  
and Missing Hours

\*\*Misc. Inputs: Anem. Hgt. (m) = 2.00 ; Decay Coef. = 0.000 ;  
Rot. Angle = 0.0

Emission Units = GRAMS/SEC ;  
Emission Rate Unit Factor = 0.10000E+07

Output Units = MICROGRAMS/M\*\*3

\*\*Approximate Storage Requirements of Model = 1.3 MB of RAM.

\*\*Input Runstream File: BDRTrip.inp

\*\*Output Print File: BDRTrip.out

\*\*Detailed Error/Message File: ERRORS.OUT

\*\*\* ISCST3 - VERSION 02035 \*\*\* \*\* MULTIPLE POINT SOURCE ISCST3 MODEL  
\*\*\* 06/07/07

\*\*\* 13:50:46 \*\*\* ENGRO CHEMICALS (DHARAKI) SINDH

\*\*MODELOPTs:  
PAGE 2

CONC RURAL FLAT FLGPOL  
MSGPRO

\*\*\* POINT SOURCE DATA \*\*\*

STACK	NUMBER STACK	EMISSION RATE BUILDING	EMISSION RATE	X	Y	BASE ELEV.	STACK HEIGHT	STACK TEMP.
SOURCE EXIT VEL.	PART. DIAMETER	(GRAMS/SEC) EXISTS	SCALAR	VARY				
ID (M/SEC)	CATS. (METERS)		BY	(METERS)	(METERS)	(METERS)	(METERS)	(DEG.K)

-----  
STACK1 0 0.14180E+02 2318105.0 1147222.6 0.0 90.00 411.00  
0.05 0.46 NO

\*\*\* ISCST3 - VERSION 02035 \*\*\* \*\* MULTIPLE POINT SOURCE ISCST3 MODEL  
\*\*\* 06/07/07

\*\*\* 13:50:46 \*\*\* ENGRO CHEMICALS (DHARAKI) SINDH

\*\*MODELOPTs:  
PAGE 3

CONC RURAL FLAT FLGPOL  
MSGPRO

\*\*\* SOURCE IDs DEFINING SOURCE GROUPS

\*\*\*  
GROUP ID SOURCE IDs  
ALL STACK1 ,

\*\*\* ISCST3 - VERSION 02035 \*\*\* \*\* MULTIPLE POINT SOURCE ISCST3 MODEL  
\*\*\* 06/07/07

\*\*\* 13:50:46 \*\*\* ENGRO CHEMICALS (DHARAKI) SINDH

\*\*MODELOPTs:  
PAGE 4

CONC RURAL FLAT FLGPOL  
MSGPRO

\*\*\* GRIDDED RECEPTOR NETWORK SUMMARY \*\*\*

\*\*\* NETWORK ID: PLANT ; NETWORK TYPE:  
GRIDCART \*\*\*



1151222.63		2.00	2.00	2.00	2.00	2.00
2.00	2.00	2.00	2.00			
1150722.63		2.00	2.00	2.00	2.00	2.00
2.00	2.00	2.00	2.00			
1150222.63		2.00	2.00	2.00	2.00	2.00
2.00	2.00	2.00	2.00			
1149722.63		2.00	2.00	2.00	2.00	2.00
2.00	2.00	2.00	2.00			
1149222.63		2.00	2.00	2.00	2.00	2.00
2.00	2.00	2.00	2.00			
1148722.63		2.00	2.00	2.00	2.00	2.00
2.00	2.00	2.00	2.00			
1148222.63		2.00	2.00	2.00	2.00	2.00
2.00	2.00	2.00	2.00			
1147722.63		2.00	2.00	2.00	2.00	2.00
2.00	2.00	2.00	2.00			
1147222.63		2.00	2.00	2.00	2.00	2.00
2.00	2.00	2.00	2.00			
1146722.63		2.00	2.00	2.00	2.00	2.00
2.00	2.00	2.00	2.00			
1146222.63		2.00	2.00	2.00	2.00	2.00
2.00	2.00	2.00	2.00			
1145722.63		2.00	2.00	2.00	2.00	2.00
2.00	2.00	2.00	2.00			
1145222.63		2.00	2.00	2.00	2.00	2.00
2.00	2.00	2.00	2.00			
1144722.63		2.00	2.00	2.00	2.00	2.00
2.00	2.00	2.00	2.00			
1144222.63		2.00	2.00	2.00	2.00	2.00
2.00	2.00	2.00	2.00			
1143722.63		2.00	2.00	2.00	2.00	2.00
2.00	2.00	2.00	2.00			
1143222.63		2.00	2.00	2.00	2.00	2.00
2.00	2.00	2.00	2.00			
1142722.63		2.00	2.00	2.00	2.00	2.00
2.00	2.00	2.00	2.00			
1142222.63		2.00	2.00	2.00	2.00	2.00
2.00	2.00	2.00	2.00			

\*\*\* ISCST3 - VERSION 02035 \*\*\*  
\*\*\* 06/07/07

\*\*\* MULTIPLE POINT SOURCE ISCST3 MODEL

\*\*\* 13:50:46

\*\*\* ENGRO CHEMICALS (DHARAKI) SINDH

\*\*MODELOPTs:  
PAGE 6

CONC RURAL FLAT FLGPOL  
MSGPRO

\*\*\* NETWORK ID: PLANT ; NETWORK TYPE:  
GRIDCART \*\*\*

\* RECEPTOR FLAGPOLE HEIGHTS IN METERS

Y-COORD (METERS)		2317605.00	2318105.00	2318605.00	2319105.00	2319605.00
2320105.00		2320605.00	2321105.00	2321605.00		
-----						
1152222.63		2.00	2.00	2.00	2.00	2.00
2.00	2.00	2.00	2.00			
1151722.63		2.00	2.00	2.00	2.00	2.00
2.00	2.00	2.00	2.00			
1151222.63		2.00	2.00	2.00	2.00	2.00
2.00	2.00	2.00	2.00			
1150722.63		2.00	2.00	2.00	2.00	2.00
2.00	2.00	2.00	2.00			
1150222.63		2.00	2.00	2.00	2.00	2.00
2.00	2.00	2.00	2.00			
1149722.63		2.00	2.00	2.00	2.00	2.00
2.00	2.00	2.00	2.00			
1149222.63		2.00	2.00	2.00	2.00	2.00
2.00	2.00	2.00	2.00			
1148722.63		2.00	2.00	2.00	2.00	2.00
2.00	2.00	2.00	2.00			
1148222.63		2.00	2.00	2.00	2.00	2.00
2.00	2.00	2.00	2.00			
1147722.63		2.00	2.00	2.00	2.00	2.00
2.00	2.00	2.00	2.00			
1147222.63		2.00	2.00	2.00	2.00	2.00
2.00	2.00	2.00	2.00			





LESS THAN 1.0 METER OR 3\*ZLB IN DISTANCE, OR WITHIN  
OPEN PIT SOURCE

SOURCE - - RECEPTOR LOCATION - -  
DISTANCE  
(METERS) ID XR (METERS) YR (METERS)

-----  
0.00 STACK1 2318105.0 1147222.6

\*\*\* ISCST3 - VERSION 02035 \*\*\* \*\* MULTIPLE POINT SOURCE ISCST3 MODEL  
\*\*\* 06/07/07

\*\*\* 13:50:46 \*\*\* ENGRO CHEMICALS (DHARAKI) SINDH

\*\*MODELOPTs:  
PAGE 9

CONC RURAL FLAT FLGPOL  
MSGPRO

\*\*\* METEOROLOGICAL DAYS SELECTED FOR  
PROCESSING \*\*\*

(1=YES; 0=NO)

1  
1 1

1  
1 1

1  
1 1

1  
1 1

1  
1 1

1  
1 1

1  
1 1

1 1

NOTE: METEOROLOGICAL DATA ACTUALLY PROCESSED WILL ALSO DEPEND ON  
WHAT IS INCLUDED IN THE DATA FILE.

SPEED CATEGORIES \*\*\*

\*\*\* UPPER BOUND OF FIRST THROUGH FIFTH WIND

(METERS/SEC)

10.80, 1.54, 3.09, 5.14, 8.23,

\*\*\* WIND PROFILE EXPONENTS \*\*\*

5	STABILITY		WIND SPEED CATEGORY			
	6	CATEGORY	1	2	3	4
01	A	.70000E-01	.70000E-01	.70000E-01	.70000E-01	.70000E-01
01	B	.70000E-01	.70000E-01	.70000E-01	.70000E-01	.70000E-01
0	C	.10000E+00	.10000E+00	.10000E+00	.10000E+00	.10000E+00
0	D	.15000E+00	.15000E+00	.15000E+00	.15000E+00	.15000E+00
0	E	.35000E+00	.35000E+00	.35000E+00	.35000E+00	.35000E+00
0	F	.55000E+00	.55000E+00	.55000E+00	.55000E+00	.55000E+00

GRADIENTS \*\*\*

\*\*\* VERTICAL POTENTIAL TEMPERATURE

(DEGREES KELVIN PER METER)

5	STABILITY		WIND SPEED CATEGORY			
	6	CATEGORY	1	2	3	4
0	A	.00000E+00	.00000E+00	.00000E+00	.00000E+00	.00000E+00
0	B	.00000E+00	.00000E+00	.00000E+00	.00000E+00	.00000E+00

C .00000E+00 .00000E+00 .00000E+00 .00000E+00 .00000E+00  
0 .00000E+00

D .00000E+00 .00000E+00 .00000E+00 .00000E+00 .00000E+00  
0 .00000E+00

E .20000E-01 .20000E-01 .20000E-01 .20000E-01 .20000E-  
01 .20000E-01 .20000E-01 .20000E-01

F .35000E-01 .35000E-01 .35000E-01 .35000E-01 .35000E-  
01 .35000E-01 .35000E-01 .35000E-01

\*\*\* ISCST3 - VERSION 02035 \*\*\* \*\* MULTIPLE POINT SOURCE ISCST3 MODEL  
\*\*\* 06/07/07

\*\*\* 13:50:46 \*\*\* ENGRO CHEMICALS (DHARAKI) SINDH

\*\*MODELOPTs:  
PAGE 10

CONC RURAL FLAT FLGPOL  
MSGPRO

\*\*\* THE FIRST 24 HOURS OF METEOROLOGICAL DATA \*\*\*

FILE: MULTAN2.ASC

FORMAT: (4I2,2F9.4,F6.1,I2,2F7.1,f9.4,f10.1,f8.4,i4,f7.2)

SURFACE STATION NO.: 41675 UPPER AIR STATION NO.:  
41675

MULTAN NAME: MULTAN NAME:

1994 YEAR: 1994 YEAR:

0 IPCODE PRATE FLOW SPEED TEMP STAB MIXING HEIGHT (M) USTAR M-O LENGTH Z-

YR MN DY HR VECTOR (M/S) (K) CLASS RURAL URBAN (M/S) (M)  
(M) (mm/HR)

94 04 01 01 179.0 0.00 290.9 7 824.0 320.0 0.0000 0.0  
0.0000 0 0.00

94 04 01 02 179.0 0.00 290.9 7 824.0 320.0 0.0000 0.0  
0.0000 0 0.00

94 04 01 03	184.0	0.00	294.3	7	824.0	320.0	0.0000	0.0
0.0000 0	0.00							
94 04 01 04	181.0	0.00	299.3	7	824.0	320.0	0.0000	0.0
0.0000 0	0.00							
94 04 01 05	179.0	0.00	303.2	7	824.0	320.0	0.0000	0.0
0.0000 0	0.00							
94 04 01 06	272.0	1.54	303.7	7	824.0	320.0	0.0000	0.0
0.0000 0	0.00							
94 04 01 07	273.0	2.57	305.4	6	88.6	374.2	0.0000	0.0
0.0000 0	0.00							
94 04 01 08	272.0	1.54	305.9	5	193.6	438.4	0.0000	0.0
0.0000 0	0.00							
94 04 01 09	266.0	1.03	307.0	4	298.7	502.7	0.0000	0.0
0.0000 0	0.00							
94 04 01 10	272.0	2.57	307.6	3	403.8	567.0	0.0000	0.0
0.0000 0	0.00							
94 04 01 11	275.0	2.57	307.0	2	508.8	631.2	0.0000	0.0
0.0000 0	0.00							
94 04 01 12	357.0	2.57	306.5	1	613.9	695.5	0.0000	0.0
0.0000 0	0.00							
94 04 01 13	358.0	1.03	304.8	1	718.9	759.7	0.0000	0.0
0.0000 0	0.00							
94 04 01 14	1.0	0.00	302.0	1	824.0	824.0	0.0000	0.0
0.0000 0	0.00							
94 04 01 15	358.0	0.00	300.4	1	824.0	824.0	0.0000	0.0
0.0000 0	0.00							
94 04 01 16	4.0	0.00	298.7	2	824.0	824.0	0.0000	0.0
0.0000 0	0.00							
94 04 01 17	358.0	0.00	297.0	2	824.0	824.0	0.0000	0.0
0.0000 0	0.00							
94 04 01 18	2.0	0.00	295.9	3	824.0	824.0	0.0000	0.0
0.0000 0	0.00							
94 04 01 19	5.0	0.00	295.9	4	841.5	841.5	0.0000	0.0
0.0000 0	0.00							
94 04 01 20	360.0	0.00	295.4	5	875.3	685.3	0.0000	0.0
0.0000 0	0.00							
94 04 01 21	2.0	0.00	294.8	6	909.0	594.0	0.0000	0.0
0.0000 0	0.00							

```

94 04 01 22    5.0    0.00  294.3    7      942.8    502.6    0.0000    0.0
0.0000    0    0.00

94 04 01 23   358.0    0.00  294.3    7      976.6    411.3    0.0000    0.0
0.0000    0    0.00

94 04 01 24    5.0    1.54  293.7    7     1010.3    320.0    0.0000    0.0
0.0000    0    0.00

```

\*\*\* NOTES: STABILITY CLASS 1=A, 2=B, 3=C, 4=D, 5=E AND 6=F.

FLOW VECTOR IS DIRECTION TOWARD WHICH WIND IS BLOWING.

\*\*\* ISCST3 - VERSION 02035 \*\*\* \*\* MULTIPLE POINT SOURCE ISCST3 MODEL  
 \*\*\* 06/07/07

\*\*\* ENGRO CHEMICALS (DHARAKI) SINDH  
 \*\*\* 13:50:46

\*\*MODELOPTs:  
 PAGE 11

CONC RURAL FLAT FLGPOL  
 MSGPRO

\*\*\* THE PERIOD ( 9480 HRS) AVERAGE CONCENTRATION  
 VALUES FOR SOURCE GROUP: ALL \*\*\*

INCLUDING SOURCE(S): STACK1 ,

\*\*\* NETWORK ID: PLANT ; NETWORK TYPE:

GRIDCART \*\*\*

\*\* CONC OF CO IN MICROGRAMS/M\*\*3

Y-COORD (METERS)	X-COORD (METERS)	2313105.00	2313605.00	2314105.00	2314605.00	2315105.00
2315605.00	2316105.00	2316605.00	2317105.00			

1152222.63	0.30188	0.50015	0.53527	0.39313	0.15952
0.04977	0.02308	0.05165	0.23203		

1151722.63	0.13748	0.33401	0.55905	0.57074	0.34526
0.11066	0.03376	0.04082	0.19286		

1151222.63	0.05559	0.14257	0.37407	0.63163	0.59737
0.27298	0.06982	0.03593	0.15438		

1150722.63	0.02251	0.05307	0.14750	0.42571	0.72300
0.59537	0.18779	0.04668	0.11745		



\*\*MODELOPTs:  
PAGE 12

...

...

\*\*MODELOPTs:  
PAGE 51

CONC	RURAL	FLAT	FLGPOL
MSGPRO			

\*\*\* Message Summary : ISCST3 Model Execution \*\*\*

----- Summary of Total Messages -----

A Total of 0 Fatal Error Message(s)  
A Total of 83 Warning Message(s)  
A Total of 5889 Informational Message(s)  
A Total of 5865 Calm Hours Identified  
A Total of 24 Missing Hours Identified

\*\*\*\*\* FATAL ERROR MESSAGES \*\*\*\*\*

\*\*\* NONE \*\*\*

\*\*\*\*\* WARNING MESSAGES \*\*\*\*\*

MX W430	1595	METQA	:Ambient Temperature Data Out-of-Range.	KURDAT=	94060611
MX W430	1596	METQA	:Ambient Temperature Data Out-of-Range.	KURDAT=	94060612
MX W430	1615	METQA	:Ambient Temperature Data Out-of-Range.	KURDAT=	94060707
MX W430	1616	METQA	:Ambient Temperature Data Out-of-Range.	KURDAT=	94060708
MX W430	1617	METQA	:Ambient Temperature Data Out-of-Range.	KURDAT=	94060709
MX W430	1618	METQA	:Ambient Temperature Data Out-of-Range.	KURDAT=	94060710
MX W430	1619	METQA	:Ambient Temperature Data Out-of-Range.	KURDAT=	94060711
MX W430	1620	METQA	:Ambient Temperature Data Out-of-Range.	KURDAT=	94060712
MX W430	1882	METQA	:Ambient Temperature Data Out-of-Range.	KURDAT=	94061810
MX W430	1883	METQA	:Ambient Temperature Data Out-of-Range.	KURDAT=	94061811
MX W430	1884	METQA	:Ambient Temperature Data Out-of-Range.	KURDAT=	94061812

MX W410	3735	METQA	:Flow Vector Out-of-Range.	KURDAT=	94090315
MX W420	3735	METQA	:Wind Speed Out-of-Range.	KURDAT=	94090315
MX W430	3735	METQA	:Ambient Temperature Data Out-of-Range.	KURDAT=	94090315
MX W410	3736	METQA	:Flow Vector Out-of-Range.	KURDAT=	94090316
MX W420	3736	METQA	:Wind Speed Out-of-Range.	KURDAT=	94090316
MX W430	3736	METQA	:Ambient Temperature Data Out-of-Range.	KURDAT=	94090316
MX W410	3737	METQA	:Flow Vector Out-of-Range.	KURDAT=	94090317
MX W420	3737	METQA	:Wind Speed Out-of-Range.	KURDAT=	94090317
MX W430	3737	METQA	:Ambient Temperature Data Out-of-Range.	KURDAT=	94090317
MX W410	3738	METQA	:Flow Vector Out-of-Range.	KURDAT=	94090318
MX W420	3738	METQA	:Wind Speed Out-of-Range.	KURDAT=	94090318
MX W430	3738	METQA	:Ambient Temperature Data Out-of-Range.	KURDAT=	94090318
MX W410	3739	METQA	:Flow Vector Out-of-Range.	KURDAT=	94090319
MX W420	3739	METQA	:Wind Speed Out-of-Range.	KURDAT=	94090319
MX W430	3739	METQA	:Ambient Temperature Data Out-of-Range.	KURDAT=	94090319
MX W410	3740	METQA	:Flow Vector Out-of-Range.	KURDAT=	94090320
MX W420	3740	METQA	:Wind Speed Out-of-Range.	KURDAT=	94090320
MX W430	3740	METQA	:Ambient Temperature Data Out-of-Range.	KURDAT=	94090320
MX W410	3741	METQA	:Flow Vector Out-of-Range.	KURDAT=	94090321
MX W420	3741	METQA	:Wind Speed Out-of-Range.	KURDAT=	94090321
MX W430	3741	METQA	:Ambient Temperature Data Out-of-Range.	KURDAT=	94090321
MX W410	3742	METQA	:Flow Vector Out-of-Range.	KURDAT=	94090322
MX W420	3742	METQA	:Wind Speed Out-of-Range.	KURDAT=	94090322
MX W430	3742	METQA	:Ambient Temperature Data Out-of-Range.	KURDAT=	94090322
MX W410	3743	METQA	:Flow Vector Out-of-Range.	KURDAT=	94090323
MX W420	3743	METQA	:Wind Speed Out-of-Range.	KURDAT=	94090323
MX W430	3743	METQA	:Ambient Temperature Data Out-of-Range.	KURDAT=	94090323
MX W410	3888	METQA	:Flow Vector Out-of-Range.	KURDAT=	94090924

MX W420	3888	METQA	:Wind Speed Out-of-Range.	KURDAT=	94090924
MX W430	3888	METQA	:Ambient Temperature Data Out-of-Range.	KURDAT=	94090924
MX W410	3889	METQA	:Flow Vector Out-of-Range.	KURDAT=	94091001
MX W420	3889	METQA	:Wind Speed Out-of-Range.	KURDAT=	94091001
MX W430	3889	METQA	:Ambient Temperature Data Out-of-Range.	KURDAT=	94091001
MX W410	3890	METQA	:Flow Vector Out-of-Range.	KURDAT=	94091002
MX W420	3890	METQA	:Wind Speed Out-of-Range.	KURDAT=	94091002
MX W430	3890	METQA	:Ambient Temperature Data Out-of-Range.	KURDAT=	94091002
MX W410	3891	METQA	:Flow Vector Out-of-Range.	KURDAT=	94091003
MX W420	3891	METQA	:Wind Speed Out-of-Range.	KURDAT=	94091003
MX W430	3891	METQA	:Ambient Temperature Data Out-of-Range.	KURDAT=	94091003
MX W410	3892	METQA	:Flow Vector Out-of-Range.	KURDAT=	94091004
MX W420	3892	METQA	:Wind Speed Out-of-Range.	KURDAT=	94091004
MX W430	3892	METQA	:Ambient Temperature Data Out-of-Range.	KURDAT=	94091004
MX W410	3893	METQA	:Flow Vector Out-of-Range.	KURDAT=	94091005
MX W420	3893	METQA	:Wind Speed Out-of-Range.	KURDAT=	94091005
MX W430	3893	METQA	:Ambient Temperature Data Out-of-Range.	KURDAT=	94091005
MX W410	3894	METQA	:Flow Vector Out-of-Range.	KURDAT=	94091006
MX W420	3894	METQA	:Wind Speed Out-of-Range.	KURDAT=	94091006
MX W430	3894	METQA	:Ambient Temperature Data Out-of-Range.	KURDAT=	94091006
MX W410	3895	METQA	:Flow Vector Out-of-Range.	KURDAT=	94091007
MX W420	3895	METQA	:Wind Speed Out-of-Range.	KURDAT=	94091007
MX W430	3895	METQA	:Ambient Temperature Data Out-of-Range.	KURDAT=	94091007
MX W410	3896	METQA	:Flow Vector Out-of-Range.	KURDAT=	94091008
MX W420	3896	METQA	:Wind Speed Out-of-Range.	KURDAT=	94091008
MX W430	3896	METQA	:Ambient Temperature Data Out-of-Range.	KURDAT=	94091008
MX W410	3897	METQA	:Flow Vector Out-of-Range.	KURDAT=	94091009
MX W420	3897	METQA	:Wind Speed Out-of-Range.	KURDAT=	94091009

MX W430 3897 METQA :Ambient Temperature Data Out-of-Range. KURDAT= 94091009  
MX W410 3898 METQA :Flow Vector Out-of-Range. KURDAT= 94091010  
MX W420 3898 METQA :Wind Speed Out-of-Range. KURDAT= 94091010  
MX W430 3898 METQA :Ambient Temperature Data Out-of-Range. KURDAT= 94091010  
MX W410 3899 METQA :Flow Vector Out-of-Range. KURDAT= 94091011  
MX W420 3899 METQA :Wind Speed Out-of-Range. KURDAT= 94091011  
MX W430 3899 METQA :Ambient Temperature Data Out-of-Range. KURDAT= 94091011  
MX W410 3900 METQA :Flow Vector Out-of-Range. KURDAT= 94091012  
MX W420 3900 METQA :Wind Speed Out-of-Range. KURDAT= 94091012  
MX W430 3900 METQA :Ambient Temperature Data Out-of-Range. KURDAT= 94091012  
MX W410 3901 METQA :Flow Vector Out-of-Range. KURDAT= 94091013  
MX W420 3901 METQA :Wind Speed Out-of-Range. KURDAT= 94091013  
MX W430 3901 METQA :Ambient Temperature Data Out-of-Range. KURDAT= 94091013  
MX W410 3902 METQA :Flow Vector Out-of-Range. KURDAT= 94091014  
MX W420 3902 METQA :Wind Speed Out-of-Range. KURDAT= 94091014  
MX W430 3902 METQA :Ambient Temperature Data Out-of-Range. KURDAT= 94091014

\*\*\*\*\*

\*\*\* ISCST3 Finishes Successfully \*\*\*

\*\*\*\*\*

```

** To run the example, type:
**   ISCST3 TEST-ST.inp  outfil.nam
** The results for this example problem are provided in file BDRFull208.out
** CONTROL OPTIONS
CO STARTING
  TITLEONE  MULTIPLE POINT SOURCE ISCST3 MODEL
  TITLETWO  ENGRO CHEMICALS (DHARAKI) SINDH
  MODELOPT  RURAL CONC MSGPRO
  AVERTIME  1 24 MONTH PERIOD
  POLLUTID  CO
**   RUNORNOT  NOT
  RUNORNOT  RUN
  TERRHGTS  FLAT
  FLAGPOLE  2
  ERRORFIL  ERRORS.OUT
CO FINISHED
** SOURCE OPTIONS
SO STARTING
**   SRCID  SRCTYP      XS      YS      ZS
**   -----
  LOCATION  STACK1  POINT  2318104.9814  1147222.6328  0.0
**
** Point Source      PTEMIS      STKHGT      STKTMP      STKVEL      STKDIA
** Parameters:      -----
  SRCPARAM  STACK1   14.19      90          411         0.0533      0.4572
** EMISUNIT
  SRCGROUP  ALL
SO FINISHED
** RECEPTOR OPTIONS
RE STARTING
RE GRIDCART PLANT STA
**   Xinit      Xnum  Xdelta      Yinit      Ynum  Ydelta
**   -----
  XYINC      2313104.9814  21    500      1142222.6328  21    500
  GRIDCART PLANT FLAG 1 21*2
  GRIDCART PLANT FLAG 2 21*2
  GRIDCART PLANT FLAG 3 21*2
  GRIDCART PLANT FLAG 4 21*2
  GRIDCART PLANT FLAG 5 21*2
  GRIDCART PLANT FLAG 6 21*2
  GRIDCART PLANT FLAG 7 21*2
  GRIDCART PLANT FLAG 8 21*2
  GRIDCART PLANT FLAG 9 21*2
  GRIDCART PLANT FLAG 10 21*2
  GRIDCART PLANT FLAG 11 21*2
  GRIDCART PLANT FLAG 12 21*2
  GRIDCART PLANT FLAG 13 21*2
  GRIDCART PLANT FLAG 14 21*2
  GRIDCART PLANT FLAG 15 21*2
  GRIDCART PLANT FLAG 16 21*2
  GRIDCART PLANT FLAG 17 21*2
  GRIDCART PLANT FLAG 18 21*2
  GRIDCART PLANT FLAG 19 21*2
  GRIDCART PLANT FLAG 20 21*2
  GRIDCART PLANT FLAG 21 21*2
  GRIDCART PLANT END
RE FINISHED
** MET OPTIONS
ME STARTING
  INPUTFIL  MULTAN2.ASC
  ANEMHGHT  2
  SURFDATA  41675 1994 MULTAN
  UAIRDATA  41675 1994 MULTAN
**   DAYRANGE  1-10
ME FINISHED
OU STARTING
  RECTABLE  ALLAVE  FIRST-SECOND
  MAXTABLE  ALLAVE  50
**   DAYTABLE  ALLAVE
  MAXIFILE  1 ALL  17347.0  MAXIALL.FIL  25
  POSTFILE  MONTH ALL PLOT PSTMNALL.PLT

```

```

POSTFILE 24 ALL PLOT PST24ALL.FIL
POSTFILE PERIOD ALL PLOT PSTPEALL.PLT
PLOTFILE MONTH ALL FIRST PLTMNALL.FIL
PLOTFILE 24 ALL FIRST PLT24ALL.PLT
PLOTFILE 1 ALL FIRST PLT1ALL.PLT
** PLOTFILE PERIOD ALL PLTPEALL.FIL
OU FINISHED
*****
*** SETUP Finishes Successfully ***
*****
*** ISCST3 - VERSION 02035 ***          *** MULTIPLE POINT SOURCE ISCST3 MODEL
***          06/07/07                    ***          ENGR0    CHEMICALS    (DHARAKI)    SINDH

***          13:32:20
**MODELOPTs:
PAGE 1
CONC          RURAL FLAT  FLGPOL          MSGPRO
-----
***          MODEL SETUP OPTIONS SUMMARY          ***
-----
**Intermediate Terrain Processing is Selected
**Model Is Setup For Calculation of Average CONCentration Values.
-- SCAVENGING/DEPOSITION LOGIC --
**Model Uses NO DRY DEPLETION.  DDPLETE = F
**Model Uses NO WET DEPLETION.  WDPLETE = F
**NO WET SCAVENGING Data Provided.
**NO GAS DRY DEPOSITION Data Provided.
**Model Does NOT Use GRIDDED TERRAIN Data for Depletion Calculations
**Model Uses RURAL Dispersion.
**Model Uses User-Specified Options:
    1. Final Plume Rise.
    2. Stack-tip Downwash.
    3. Buoyancy-induced Dispersion.
    4. Calms Processing Routine.
    5. Missing Data Processing Routine.
    6. Default Wind Profile Exponents.
    7. Default Vertical Potential Temperature Gradients.
**Model Assumes Receptors on FLAT Terrain.
**Model Accepts FLAGPOLE Receptor Heights.
**Model Calculates 3 Short Term Average(s) of:  1-HR  24-HR  MONTH
and Calculates PERIOD Averages
**This Run Includes:  1 Source(s);  1 Source Group(s); and  441 Receptor(s)
**The Model Assumes A Pollutant Type of:  CO
**Model Set To Continue RUNning After the Setup Testing.
**Output Options Selected:
    Model Outputs Tables of PERIOD Averages by Receptor
    Model Outputs Tables of Highest Short Term Values by Receptor (RECTABLE Keyword)
    Model Outputs Tables of Overall Maximum Short Term Values (MAXTABLE Keyword)
    Model Outputs External File(s) of Threshold Violations (MAXIFILE Keyword)
    Model Outputs External File(s) of Concurrent Values for Postprocessing (POSTFILE
Keyword)
    Model Outputs External File(s) of High Values for Plotting (PLOTFILE Keyword)
**NOTE:  The Following Flags May Appear Following CONC Values:  c for Calm Hours
                                                    m for Missing Hours
                                                    b for Both Calm and
Missing Hours
**Misc. Inputs:  Anem. Hgt. (m) = 2.00 ;  Decay Coef. = 0.000 ;  Rot.
Angle = 0.0
Emission Units = GRAMS/SEC ;  Emission
Rate Unit Factor = 0.10000E+07
Output Units = MICROGRAMS/M**3
**Approximate Storage Requirements of Model = 1.3 MB of RAM.
**Input Runstream File:  full208.inp
**Output Print File:  full208.out
**Detailed Error/Message File:  ERRORS.OUT
*** ISCST3 - VERSION 02035 ***          *** MULTIPLE POINT SOURCE ISCST3 MODEL
***          06/07/07                    ***          ENGR0    CHEMICALS    (DHARAKI)    SINDH

***          13:32:20
**MODELOPTs:
PAGE 2

```



1148722.63		2.00	2.00	2.00	2.00	2.00
2.00	2.00	2.00	2.00	2.00	2.00	2.00
1148222.63		2.00	2.00	2.00	2.00	2.00
2.00	2.00	2.00	2.00	2.00	2.00	2.00
1147722.63		2.00	2.00	2.00	2.00	2.00
2.00	2.00	2.00	2.00	2.00	2.00	2.00
1147222.63		2.00	2.00	2.00	2.00	2.00
2.00	2.00	2.00	2.00	2.00	2.00	2.00
1146722.63		2.00	2.00	2.00	2.00	2.00
2.00	2.00	2.00	2.00	2.00	2.00	2.00
1146222.63		2.00	2.00	2.00	2.00	2.00
2.00	2.00	2.00	2.00	2.00	2.00	2.00
1145722.63		2.00	2.00	2.00	2.00	2.00
2.00	2.00	2.00	2.00	2.00	2.00	2.00
1145222.63		2.00	2.00	2.00	2.00	2.00
2.00	2.00	2.00	2.00	2.00	2.00	2.00
1144722.63		2.00	2.00	2.00	2.00	2.00
2.00	2.00	2.00	2.00	2.00	2.00	2.00
1144222.63		2.00	2.00	2.00	2.00	2.00
2.00	2.00	2.00	2.00	2.00	2.00	2.00
1143722.63		2.00	2.00	2.00	2.00	2.00
2.00	2.00	2.00	2.00	2.00	2.00	2.00
1143222.63		2.00	2.00	2.00	2.00	2.00
2.00	2.00	2.00	2.00	2.00	2.00	2.00
1142722.63		2.00	2.00	2.00	2.00	2.00
2.00	2.00	2.00	2.00	2.00	2.00	2.00
1142222.63		2.00	2.00	2.00	2.00	2.00
2.00	2.00	2.00	2.00	2.00	2.00	2.00

\*\*\* ISCST3 - VERSION 02035 \*\*\* \*\* MULTIPLE POINT SOURCE ISCST3 MODEL  
 \*\*\* 06/07/07

\*\*\* ENGRO CHEMICALS (DHARAKI) SINDH

\*\*\* 13:32:20

\*\*MODELOPTs:

PAGE 6

CONC

RURAL FLAT FLGPOL MSGPRO

\*\*\* NETWORK ID: PLANT ; NETWORK TYPE: GRIDCART \*\*\*

\* RECEPTOR FLAGPOLE HEIGHTS IN METERS \*

Y-COORD (METERS)		2317605.00	2318105.00	2318605.00	2319105.00	2319605.00
2320105.00		2320605.00	2321105.00	2321605.00		

1152222.63		2.00	2.00	2.00	2.00	2.00
2.00	2.00	2.00	2.00	2.00	2.00	2.00
1151722.63		2.00	2.00	2.00	2.00	2.00
2.00	2.00	2.00	2.00	2.00	2.00	2.00
1151222.63		2.00	2.00	2.00	2.00	2.00
2.00	2.00	2.00	2.00	2.00	2.00	2.00
1150722.63		2.00	2.00	2.00	2.00	2.00
2.00	2.00	2.00	2.00	2.00	2.00	2.00
1150222.63		2.00	2.00	2.00	2.00	2.00
2.00	2.00	2.00	2.00	2.00	2.00	2.00
1149722.63		2.00	2.00	2.00	2.00	2.00
2.00	2.00	2.00	2.00	2.00	2.00	2.00
1149222.63		2.00	2.00	2.00	2.00	2.00
2.00	2.00	2.00	2.00	2.00	2.00	2.00
1148722.63		2.00	2.00	2.00	2.00	2.00
2.00	2.00	2.00	2.00	2.00	2.00	2.00
1148222.63		2.00	2.00	2.00	2.00	2.00
2.00	2.00	2.00	2.00	2.00	2.00	2.00
1147722.63		2.00	2.00	2.00	2.00	2.00
2.00	2.00	2.00	2.00	2.00	2.00	2.00
1147222.63		2.00	2.00	2.00	2.00	2.00
2.00	2.00	2.00	2.00	2.00	2.00	2.00
1146722.63		2.00	2.00	2.00	2.00	2.00
2.00	2.00	2.00	2.00	2.00	2.00	2.00
1146222.63		2.00	2.00	2.00	2.00	2.00
2.00	2.00	2.00	2.00	2.00	2.00	2.00
1145722.63		2.00	2.00	2.00	2.00	2.00
2.00	2.00	2.00	2.00	2.00	2.00	2.00
1145222.63		2.00	2.00	2.00	2.00	2.00
2.00	2.00	2.00	2.00	2.00	2.00	2.00

1144722.63		2.00	2.00	2.00	2.00	2.00	2.00
2.00	2.00	2.00	2.00	2.00	2.00	2.00	2.00
1144222.63		2.00	2.00	2.00	2.00	2.00	2.00
2.00	2.00	2.00	2.00	2.00	2.00	2.00	2.00
1143722.63		2.00	2.00	2.00	2.00	2.00	2.00
2.00	2.00	2.00	2.00	2.00	2.00	2.00	2.00
1143222.63		2.00	2.00	2.00	2.00	2.00	2.00
2.00	2.00	2.00	2.00	2.00	2.00	2.00	2.00
1142722.63		2.00	2.00	2.00	2.00	2.00	2.00
2.00	2.00	2.00	2.00	2.00	2.00	2.00	2.00
1142222.63		2.00	2.00	2.00	2.00	2.00	2.00
2.00	2.00	2.00	2.00	2.00	2.00	2.00	2.00

\*\*\* ISCST3 - VERSION 02035 \*\*\* \*\* MULTIPLE POINT SOURCE ISCST3 MODEL  
 \*\*\* 06/07/07 \*\*\* ENGRO CHEMICALS (DHARAKI) SINDH

\*\*\* 13:32:20

\*\*MODELOPTs:

PAGE 7

CONC RURAL FLAT FLGPOL MSGPRO  
 \*\*\* NETWORK ID: PLANT ; NETWORK TYPE: GRIDCART \*\*\*  
 \* RECEPTOR FLAGPOLE HEIGHTS IN METERS \*  
 X-COORD (METERS)

Y-COORD (METERS)	2322105.00	2322605.00	2323105.00
1152222.63	2.00	2.00	2.00
1151722.63	2.00	2.00	2.00
1151222.63	2.00	2.00	2.00
1150722.63	2.00	2.00	2.00
1150222.63	2.00	2.00	2.00
1149722.63	2.00	2.00	2.00
1149222.63	2.00	2.00	2.00
1148722.63	2.00	2.00	2.00
1148222.63	2.00	2.00	2.00
1147722.63	2.00	2.00	2.00
1147222.63	2.00	2.00	2.00
1146722.63	2.00	2.00	2.00
1146222.63	2.00	2.00	2.00
1145722.63	2.00	2.00	2.00
1145222.63	2.00	2.00	2.00
1144722.63	2.00	2.00	2.00
1144222.63	2.00	2.00	2.00
1143722.63	2.00	2.00	2.00
1143222.63	2.00	2.00	2.00
1142722.63	2.00	2.00	2.00
1142222.63	2.00	2.00	2.00

\*\*\* ISCST3 - VERSION 02035 \*\*\* \*\* MULTIPLE POINT SOURCE ISCST3 MODEL  
 \*\*\* 06/07/07 \*\*\* ENGRO CHEMICALS (DHARAKI) SINDH

\*\*\* 13:32:20

\*\*MODELOPTs:

PAGE 8

CONC RURAL FLAT FLGPOL MSGPRO  
 \* SOURCE-RECEPTOR COMBINATIONS FOR WHICH CALCULATIONS MAY NOT BE PERFORMED \*  
 LESS THAN 1.0 METER OR 3\*ZLB IN DISTANCE, OR WITHIN OPEN PIT

SOURCE	SOURCE ID	- - RECEPTOR LOCATION - -	DISTANCE (METERS)
		XR (METERS) YR (METERS)	

*** ISCST3 - VERSION 02035 ***	STACK1	2318105.0 1147222.6	0.00
*** 06/07/07		*** MULTIPLE POINT SOURCE	ISCST3 MODEL

\*\*\* 13:32:20 \*\*\* ENGRO CHEMICALS (DHARAKI) SINDH

\*\*MODELOPTs:

PAGE 9

CONC RURAL FLAT FLGPOL MSGPRO  
 \*\*\* METEOROLOGICAL DAYS SELECTED FOR PROCESSING \*\*\*

(1=YES; 0=NO)



FORMAT: (4I2,2F9.4,F6.1,I2,2F7.1,f9.4,f10.1,f8.4,i4,f7.2)

SURFACE STATION NO.: 41675 UPPER AIR STATION NO.: 41675

NAME: MULTAN

NAME: MULTAN

YEAR: 1994

YEAR: 1994

PRATE	YR	MN	DY	HR	VECTOR	(M/S)	(K)	CLASS	RURAL	URBAN	(M/S)	(M)	(M)
(mm/HR)													
0.00	94	04	01	01	179.0	0.00	290.9	7	824.0	320.0	0.0000	0.0	0.0000 0
0.00	94	04	01	02	179.0	0.00	290.9	7	824.0	320.0	0.0000	0.0	0.0000 0
0.00	94	04	01	03	184.0	0.00	294.3	7	824.0	320.0	0.0000	0.0	0.0000 0
0.00	94	04	01	04	181.0	0.00	299.3	7	824.0	320.0	0.0000	0.0	0.0000 0
0.00	94	04	01	05	179.0	0.00	303.2	7	824.0	320.0	0.0000	0.0	0.0000 0
0.00	94	04	01	06	272.0	1.54	303.7	7	824.0	320.0	0.0000	0.0	0.0000 0
0.00	94	04	01	07	273.0	2.57	305.4	6	88.6	374.2	0.0000	0.0	0.0000 0
0.00	94	04	01	08	272.0	1.54	305.9	5	193.6	438.4	0.0000	0.0	0.0000 0
0.00	94	04	01	09	266.0	1.03	307.0	4	298.7	502.7	0.0000	0.0	0.0000 0
0.00	94	04	01	10	272.0	2.57	307.6	3	403.8	567.0	0.0000	0.0	0.0000 0
0.00	94	04	01	11	275.0	2.57	307.0	2	508.8	631.2	0.0000	0.0	0.0000 0
0.00	94	04	01	12	357.0	2.57	306.5	1	613.9	695.5	0.0000	0.0	0.0000 0
0.00	94	04	01	13	358.0	1.03	304.8	1	718.9	759.7	0.0000	0.0	0.0000 0
0.00	94	04	01	14	1.0	0.00	302.0	1	824.0	824.0	0.0000	0.0	0.0000 0
0.00	94	04	01	15	358.0	0.00	300.4	1	824.0	824.0	0.0000	0.0	0.0000 0
0.00	94	04	01	16	4.0	0.00	298.7	2	824.0	824.0	0.0000	0.0	0.0000 0
0.00	94	04	01	17	358.0	0.00	297.0	2	824.0	824.0	0.0000	0.0	0.0000 0
0.00	94	04	01	18	2.0	0.00	295.9	3	824.0	824.0	0.0000	0.0	0.0000 0
0.00	94	04	01	19	5.0	0.00	295.9	4	841.5	841.5	0.0000	0.0	0.0000 0
0.00	94	04	01	20	360.0	0.00	295.4	5	875.3	685.3	0.0000	0.0	0.0000 0
0.00	94	04	01	21	2.0	0.00	294.8	6	909.0	594.0	0.0000	0.0	0.0000 0
0.00	94	04	01	22	5.0	0.00	294.3	7	942.8	502.6	0.0000	0.0	0.0000 0
0.00	94	04	01	23	358.0	0.00	294.3	7	976.6	411.3	0.0000	0.0	0.0000 0
0.00	94	04	01	24	5.0	1.54	293.7	7	1010.3	320.0	0.0000	0.0	0.0000 0

\*\*\* NOTES: STABILITY CLASS 1=A, 2=B, 3=C, 4=D, 5=E AND 6=F.

FLOW VECTOR IS DIRECTION TOWARD WHICH WIND IS BLOWING.

\*\*\* ISCST3 - VERSION 02035 \*\*\* \*\* MULTIPLE POINT SOURCE ISCST3 MODEL  
\*\*\* 06/07/07

\*\*\* 13:32:20 \*\*\* ENGRO CHEMICALS (DHARAKI) SINDH

\*\*MODELOPTs:

PAGE 11

CONC

RURAL FLAT FLGPOL

MSGPRO

\*\*\* THE PERIOD ( 9480 HRS) AVERAGE CONCENTRATION VALUES  
FOR SOURCE GROUP: ALL \*\*\*

INCLUDING SOURCE(S):

STACK1 ,

\*\*\* NETWORK ID: PLANT

; NETWORK TYPE: GRIDCART \*\*\*

\*\* CONC OF CO

IN MICROGRAMS/M\*\*3

Y-COORD (METERS)	X-COORD (METERS)					
	2313105.00	2313605.00	2314105.00	2314605.00	2315105.00	
2315605.00	2316105.00	2316605.00	2317105.00			
1152222.63	0.30208	0.50048	0.53562	0.39339	0.15963	
0.04981	0.02309	0.05168	0.23219			
1151722.63	0.13758	0.33424	0.55942	0.57112	0.34550	
0.11073	0.03378	0.04085	0.19299			
1151222.63	0.05563	0.14267	0.37432	0.63205	0.59777	
0.27317	0.06987	0.03595	0.15449			
1150722.63	0.02252	0.05310	0.14760	0.42600	0.72348	
0.59577	0.18792	0.04671	0.11753			
1150222.63	0.00816	0.01927	0.04959	0.15213	0.49555	
0.84001	0.53347	0.11050	0.08648			
1149722.63	0.00288	0.00598	0.01537	0.04465	0.15593	
0.59357	0.98296	0.39373	0.08199			
1149222.63	0.00372	0.00312	0.00437	0.01104	0.03752	
0.15822	0.74331	1.12755	0.21937			
1148722.63	0.01473	0.01080	0.00743	0.00543	0.00755	
0.02735	0.15538	0.99705	1.12600			
1148222.63	0.06683	0.05454	0.04284	0.03174	0.02131	
0.01307	0.01685	0.13206	1.49331			
1147722.63	0.29082	0.28720	0.27649	0.25575	0.22395	
0.18185	0.13205	0.07484	0.07489			
1147222.63	0.40261	0.44161	0.48992	0.54964	0.62848	
0.73618	0.89458	1.13924	1.51243			
1146722.63	0.21041	0.20407	0.19389	0.17892	0.15886	
0.13335	0.10510	0.11411	0.86115			
1146222.63	0.04517	0.03759	0.03061	0.02571	0.02813	
0.06287	0.29304	1.69980	2.25556			
1145722.63	0.01216	0.01308	0.02006	0.04607	0.14562	
0.56751	1.70116	1.50845	0.16777			
1145222.63	0.01736	0.03613	0.08982	0.26150	0.77173	
1.45394	1.11184	0.20845	0.02477			
1144722.63	0.06278	0.14957	0.38461	0.85355	1.20802	
0.87411	0.22244	0.03398	0.03118			
1144222.63	0.21991	0.48551	0.84376	1.01025	0.71796	
0.22556	0.04798	0.01090	0.05947			
1143722.63	0.54686	0.79185	0.85828	0.60795	0.22319	
0.05910	0.01374	0.01118	0.09852			
1143222.63	0.72745	0.74111	0.52684	0.21775	0.06754	
0.01922	0.00623	0.01785	0.14619			
1142722.63	0.64925	0.46466	0.21067	0.07401	0.02463	
0.00745	0.00588	0.02801	0.20198			
1142222.63	0.41546	0.20282	0.07895	0.02943	0.01006	
0.00406	0.00819	0.04105	0.26435			

\*\*\* ISCST3 - VERSION 02035 \*\*\* \*\* MULTIPLE POINT SOURCE ISCST3 MODEL  
 \*\*\* 06/07/07 \*\*\* ENGRO CHEMICALS (DHARAKI) SINDH

\*\*\* 13:32:20

\*\*MODELOPTs:

PAGE 12

...  
 ...

CONC RURAL FLAT FLGPOL MSGPRO

\*\*\* Message Summary : ISCST3 Model Execution \*\*\*

----- Summary of Total Messages -----

A Total of 0 Fatal Error Message(s)  
 A Total of 83 Warning Message(s)  
 A Total of 5889 Informational Message(s)  
 A Total of 5865 Calm Hours Identified  
 A Total of 24 Missing Hours Identified

\*\*\*\*\* FATAL ERROR MESSAGES \*\*\*\*\*  
 \*\*\* NONE \*\*\*

\*\*\*\*\* WARNING MESSAGES \*\*\*\*\*

MX W430 1595 METQA :Ambient Temperature Data Out-of-Range. KURDAT= 94060611  
 MX W430 1596 METQA :Ambient Temperature Data Out-of-Range. KURDAT= 94060612  
 MX W430 1615 METQA :Ambient Temperature Data Out-of-Range. KURDAT= 94060707  
 MX W430 1616 METQA :Ambient Temperature Data Out-of-Range. KURDAT= 94060708  
 MX W430 1617 METQA :Ambient Temperature Data Out-of-Range. KURDAT= 94060709  
 MX W430 1618 METQA :Ambient Temperature Data Out-of-Range. KURDAT= 94060710



```

** To run the example, type:
**   ISCST3 TEST-ST.inp  outfil.nam
** The results for this example problem are provided in file L201NOX.out
** CONTROL OPTIONS
CO STARTING
TITLEONE  MULTIPLE POINT SOURCE ISCST3 MODEL
TITLETWO  ENGRO CHEMICALS (DHARAKI) SINDH
MODELOPT  RURAL  CONC MSGPRO
AVERTIME  1 24 MONTH PERIOD
POLLUTID  NOX
**   RUNORNOT  NOT
      RUNORNOT  RUN
      TERRHGTS  FLAT
      FLAGPOLE  2
      ERRORFIL  ERRORS.OUT
CO FINISHED
** SOURCE OPTIONS
SO STARTING
**   SRCID  SRCTYP      XS      YS      ZS
**   -----
LOCATION  STACK1  POINT  2318062.3404  1147099.3560  0.0
** Point Source      PTEMIS  STKHGT  STKTMP  STKVEL  STKDIA
** Parameters:
SRCPARAM  STACK1  26.58      60.66      438      0.001  1.6764
** EMISUNIT
SRCGROUP  ALL
SO FINISHED
** RECEPTOR OPTIONS
RE STARTING
RE GRIDCART  PLANT STA
**
**   Xinit      Xnum  Xdelta      Yinit      Ynum  Ydelta
**   -----
XYINC  2313062.3404  21    500    1142099.3560  21    500
GRIDCART  PLANT FLAG 1 21*2
GRIDCART  PLANT FLAG 2 21*2
GRIDCART  PLANT FLAG 3 21*2
GRIDCART  PLANT FLAG 4 21*2
GRIDCART  PLANT FLAG 5 21*2
GRIDCART  PLANT FLAG 6 21*2
GRIDCART  PLANT FLAG 7 21*2
GRIDCART  PLANT FLAG 8 21*2
GRIDCART  PLANT FLAG 9 21*2
GRIDCART  PLANT FLAG 10 21*2
GRIDCART  PLANT FLAG 11 21*2
GRIDCART  PLANT FLAG 12 21*2
GRIDCART  PLANT FLAG 13 21*2
GRIDCART  PLANT FLAG 14 21*2
GRIDCART  PLANT FLAG 15 21*2
GRIDCART  PLANT FLAG 16 21*2
GRIDCART  PLANT FLAG 17 21*2
GRIDCART  PLANT FLAG 18 21*2
GRIDCART  PLANT FLAG 19 21*2
GRIDCART  PLANT FLAG 20 21*2
GRIDCART  PLANT FLAG 21 21*2
GRIDCART  PLANT END
RE FINISHED
** MET OPTIONS
ME STARTING
INPUTFIL  MULTAN2.ASC
ANEMHGHT  2
SURFDATA  41675  1994  MULTAN
UAIRDATA  41675  1994  MULTAN
**   DAYRANGE  1-10
ME FINISHED
OU STARTING
RECTABLE  ALLAVE  FIRST-SECOND
MAXTABLE  ALLAVE  50
**   DAYTABLE  ALLAVE
MAXIFILE  1 ALL  17347.0  MAXIALL.FIL  25
POSTFILE  MONTH  ALL PLOT  PSTMNALL.PLT
POSTFILE  24 ALL PLOT  PST24ALL.FIL

```

POSTFILE PERIOD ALL PLOT PSTPEALL.PLT  
PLOTFILE MONTH ALL FIRST PLTMNALL.FIL  
PLOTFILE 24 ALL FIRST PLT24ALL.PLT  
PLOTFILE 1 ALL FIRST PLT1ALL.PLT  
\*\* PLOTFILE PERIOD ALL PLTPEALL.FIL

OU FINISHED

\*\*\*\*\*

\*\*\* SETUP Finishes Successfully \*\*\*

\*\*\*\*\*

\*\*\* ISCST3 - VERSION 02035 \*\*\* \*\* MULTIPLE POINT SOURCE ISCST3 MODEL  
\*\*\* 06/07/07 \*\*\*

\*\*\* 12:41:07

\*\*MODELOPTs:

PAGE 1

CONC

RURAL FLAT FLGPOL

MSGPRO

\*\*\* MODEL SETUP OPTIONS SUMMARY \*\*\*

-----  
\*\*Intermediate Terrain Processing is Selected

\*\*Model Is Setup For Calculation of Average CONCentration Values.

-- SCAVENGING/DEPOSITION LOGIC --

\*\*Model Uses NO DRY DEPLETION. DDPLETE = F

\*\*Model Uses NO WET DEPLETION. WDPLETE = F

\*\*NO WET SCAVENGING Data Provided.

\*\*NO GAS DRY DEPOSITION Data Provided.

\*\*Model Does NOT Use GRIDDED TERRAIN Data for Depletion Calculations

\*\*Model Uses RURAL Dispersion.

\*\*Model Uses User-Specified Options:

1. Final Plume Rise.
2. Stack-tip Downwash.
3. Buoyancy-induced Dispersion.
4. Calms Processing Routine.
5. Missing Data Processing Routine.
6. Default Wind Profile Exponents.
7. Default Vertical Potential Temperature Gradients.

\*\*Model Assumes Receptors on FLAT Terrain.

\*\*Model Accepts FLAGPOLE Receptor Heights.

\*\*Model Calculates 3 Short Term Average(s) of: 1-HR 24-HR MONTH

and Calculates PERIOD Averages

\*\*This Run Includes: 1 Source(s); 1 Source Group(s); and 441 Receptor(s)

\*\*The Model Assumes A Pollutant Type of: NOX

\*\*Model Set To Continue RUNNING After the Setup Testing.

\*\*Output Options Selected:

Model Outputs Tables of PERIOD Averages by Receptor

Model Outputs Tables of Highest Short Term Values by Receptor (RECTABLE Keyword)

Model Outputs Tables of Overall Maximum Short Term Values (MAXTABLE Keyword)

Model Outputs External File(s) of Threshold Violations (MAXIFILE Keyword)

Model Outputs External File(s) of Concurrent Values for Postprocessing (POSTFILE Keyword)

Model Outputs External File(s) of High Values for Plotting (PLOTFILE Keyword)

\*\*NOTE: The Following Flags May Appear Following CONC Values: c for Calm Hours

m for Missing Hours

b for Both Calm and Missing Hours

\*\*Misc. Inputs: Anem. Hgt. (m) = 2.00 ; Decay Coef. = 0.000 ; Rot. Angle = 0.0  
Emission Units = GRAMS/SEC ; Emission Rate Unit

Factor = 0.10000E+07

Output Units = MICROGRAMS/M\*\*3

\*\*Approximate Storage Requirements of Model = 1.3 MB of RAM.

\*\*Input Runstream File: L201NOX.inp

\*\*Output Print File: L201NOX.out

\*\*Detailed Error/Message File: ERRORS.OUT

\*\*\* ISCST3 - VERSION 02035 \*\*\* \*\* MULTIPLE POINT SOURCE ISCST3 MODEL  
\*\*\* 06/07/07 \*\*\*

\*\*\* 12:41:07

\*\*MODELOPTs:

PAGE 2

CONC

RURAL FLAT FLGPOL

MSGPRO

\*\*\* POINT SOURCE DATA \*\*\*

NUMBER EMISSION RATE BASE STACK STACK STACK STACK  
BUILDING EMISSION RATE

SOURCE PART. (GRAMS/SEC) X Y ELEV. HEIGHT TEMP. EXIT VEL. DIAMETER  
 EXISTS SCALAR VARY  
 ID CATS. (METERS) (METERS) (METERS) (METERS) (DEG.K) (M/SEC) (METERS)  
 BY

-----  
 STACK1 0 0.26580E+02 2318062.3 1147099.4 0.0 60.66 438.00 0.00 1.68

NO  
 \*\*\* ISCST3 - VERSION 02035 \*\*\* \*\* MULTIPLE POINT SOURCE ISCST3 MODEL  
 \*\*\* 06/07/07 \*\*\*

\*\*\* 12:41:07  
 \*\*\* ENGRO CHEMICALS (DHARAKI) SINDH

\*\*MODELOPTs:

PAGE 3

CONC RURAL FLAT FLGPOL MSGPRO  
 \*\*\* SOURCE IDs DEFINING SOURCE GROUPS \*\*\*  
 SOURCE IDs

GROUP ID

ALL STACK1 ,  
 \*\*\* ISCST3 - VERSION 02035 \*\*\* \*\* MULTIPLE POINT SOURCE ISCST3 MODEL  
 \*\*\* 06/07/07 \*\*\*

\*\*\* 12:41:07  
 \*\*\* ENGRO CHEMICALS (DHARAKI) SINDH

\*\*MODELOPTs:

PAGE 4

CONC RURAL FLAT FLGPOL MSGPRO  
 \*\*\* GRIDDED RECEPTOR NETWORK SUMMARY \*\*\*  
 \*\*\* NETWORK ID: PLANT ; NETWORK TYPE: GRIDCART \*\*\*  
 \*\*\* X-COORDINATES OF GRID \*\*\*

(METERS)  
 2313062.3, 2313562.3, 2314062.3, 2314562.3, 2315062.3, 2315562.3, 2316062.3, 2316562.3,  
 2317062.3, 2317562.3,  
 2318062.3, 2318562.3, 2319062.3, 2319562.3, 2320062.3, 2320562.3, 2321062.3, 2321562.3,  
 2322062.3, 2322562.3,  
 2323062.3,

\*\*\* Y-COORDINATES OF GRID \*\*\*  
 (METERS)

1142099.4, 1142599.4, 1143099.4, 1143599.4, 1144099.4, 1144599.4, 1145099.4, 1145599.4,  
 1146099.4, 1146599.4,  
 1147099.4, 1147599.4, 1148099.4, 1148599.4, 1149099.4, 1149599.4, 1150099.4, 1150599.4,  
 1151099.4, 1151599.4,  
 1152099.4,

\*\*\* ISCST3 - VERSION 02035 \*\*\* \*\* MULTIPLE POINT SOURCE ISCST3 MODEL  
 \*\*\* 06/07/07 \*\*\*

\*\*\* 12:41:07  
 \*\*\* ENGRO CHEMICALS (DHARAKI) SINDH

\*\*MODELOPTs:

PAGE 5

CONC RURAL FLAT FLGPOL MSGPRO  
 \*\*\* NETWORK ID: PLANT ; NETWORK TYPE: GRIDCART \*\*\*  
 \* RECEPTOR FLAGPOLE HEIGHTS IN METERS \*

Y-COORD (METERS)	2313062.25	2313562.25	2314062.25	2314562.25	2315062.25	2315562.25
2316062.25	2316562.25	2317062.25				

1152099.38	2.00	2.00	2.00	2.00	2.00	2.00
2.00	2.00	2.00				
1151599.38	2.00	2.00	2.00	2.00	2.00	2.00
2.00	2.00	2.00				
1151099.38	2.00	2.00	2.00	2.00	2.00	2.00
2.00	2.00	2.00				
1150599.38	2.00	2.00	2.00	2.00	2.00	2.00
2.00	2.00	2.00				
1150099.38	2.00	2.00	2.00	2.00	2.00	2.00
2.00	2.00	2.00				
1149599.38	2.00	2.00	2.00	2.00	2.00	2.00
2.00	2.00	2.00				
1149099.38	2.00	2.00	2.00	2.00	2.00	2.00
2.00	2.00	2.00				
1148599.38	2.00	2.00	2.00	2.00	2.00	2.00
2.00	2.00	2.00				

1148099.38		2.00	2.00	2.00	2.00	2.00	2.00
2.00	2.00	2.00					
1147599.38		2.00	2.00	2.00	2.00	2.00	2.00
2.00	2.00	2.00					
1147099.38		2.00	2.00	2.00	2.00	2.00	2.00
2.00	2.00	2.00					
1146599.38		2.00	2.00	2.00	2.00	2.00	2.00
2.00	2.00	2.00					
1146099.38		2.00	2.00	2.00	2.00	2.00	2.00
2.00	2.00	2.00					
1145599.38		2.00	2.00	2.00	2.00	2.00	2.00
2.00	2.00	2.00					
1145099.38		2.00	2.00	2.00	2.00	2.00	2.00
2.00	2.00	2.00					
1144599.38		2.00	2.00	2.00	2.00	2.00	2.00
2.00	2.00	2.00					
1144099.38		2.00	2.00	2.00	2.00	2.00	2.00
2.00	2.00	2.00					
1143599.38		2.00	2.00	2.00	2.00	2.00	2.00
2.00	2.00	2.00					
1143099.38		2.00	2.00	2.00	2.00	2.00	2.00
2.00	2.00	2.00					
1142599.38		2.00	2.00	2.00	2.00	2.00	2.00
2.00	2.00	2.00					
1142099.38		2.00	2.00	2.00	2.00	2.00	2.00
2.00	2.00	2.00					

\*\*\* ISCST3 - VERSION 02035 \*\*\* \*\* MULTIPLE POINT SOURCE ISCST3 MODEL  
 \*\*\* 06/07/07 \*\*\* ENGRO CHEMICALS (DHARAKI) SINDH

\*\*\* 12:41:07

\*\*MODELOPTs:

PAGE 6

CONC

RURAL FLAT FLGPOL

MSGPRO

\*\*\* NETWORK ID: PLANT ; NETWORK TYPE: GRIDCART \*\*\*

\* RECEPTOR FLAGPOLE HEIGHTS IN METERS \*

Y-COORD (METERS)		2317562.25	2318062.25	2318562.25	2319062.25	2319562.25	2320062.25
2320562.25	2321062.25	2321562.25					

1152099.38		2.00	2.00	2.00	2.00	2.00	2.00
2.00	2.00	2.00					
1151599.38		2.00	2.00	2.00	2.00	2.00	2.00
2.00	2.00	2.00					
1151099.38		2.00	2.00	2.00	2.00	2.00	2.00
2.00	2.00	2.00					
1150599.38		2.00	2.00	2.00	2.00	2.00	2.00
2.00	2.00	2.00					
1150099.38		2.00	2.00	2.00	2.00	2.00	2.00
2.00	2.00	2.00					
1149599.38		2.00	2.00	2.00	2.00	2.00	2.00
2.00	2.00	2.00					
1149099.38		2.00	2.00	2.00	2.00	2.00	2.00
2.00	2.00	2.00					
1148599.38		2.00	2.00	2.00	2.00	2.00	2.00
2.00	2.00	2.00					
1148099.38		2.00	2.00	2.00	2.00	2.00	2.00
2.00	2.00	2.00					
1147599.38		2.00	2.00	2.00	2.00	2.00	2.00
2.00	2.00	2.00					
1147099.38		2.00	2.00	2.00	2.00	2.00	2.00
2.00	2.00	2.00					
1146599.38		2.00	2.00	2.00	2.00	2.00	2.00
2.00	2.00	2.00					
1146099.38		2.00	2.00	2.00	2.00	2.00	2.00
2.00	2.00	2.00					
1145599.38		2.00	2.00	2.00	2.00	2.00	2.00
2.00	2.00	2.00					
1145099.38		2.00	2.00	2.00	2.00	2.00	2.00
2.00	2.00	2.00					
1144599.38		2.00	2.00	2.00	2.00	2.00	2.00
2.00	2.00	2.00					





94 04 01 09	266.0	1.03	307.0	4	298.7	502.7	0.0000	0.0	0.0000	0	0.00
94 04 01 10	272.0	2.57	307.6	3	403.8	567.0	0.0000	0.0	0.0000	0	0.00
94 04 01 11	275.0	2.57	307.0	2	508.8	631.2	0.0000	0.0	0.0000	0	0.00
94 04 01 12	357.0	2.57	306.5	1	613.9	695.5	0.0000	0.0	0.0000	0	0.00
94 04 01 13	358.0	1.03	304.8	1	718.9	759.7	0.0000	0.0	0.0000	0	0.00
94 04 01 14	1.0	0.00	302.0	1	824.0	824.0	0.0000	0.0	0.0000	0	0.00
94 04 01 15	358.0	0.00	300.4	1	824.0	824.0	0.0000	0.0	0.0000	0	0.00
94 04 01 16	4.0	0.00	298.7	2	824.0	824.0	0.0000	0.0	0.0000	0	0.00
94 04 01 17	358.0	0.00	297.0	2	824.0	824.0	0.0000	0.0	0.0000	0	0.00
94 04 01 18	2.0	0.00	295.9	3	824.0	824.0	0.0000	0.0	0.0000	0	0.00
94 04 01 19	5.0	0.00	295.9	4	841.5	841.5	0.0000	0.0	0.0000	0	0.00
94 04 01 20	360.0	0.00	295.4	5	875.3	685.3	0.0000	0.0	0.0000	0	0.00
94 04 01 21	2.0	0.00	294.8	6	909.0	594.0	0.0000	0.0	0.0000	0	0.00
94 04 01 22	5.0	0.00	294.3	7	942.8	502.6	0.0000	0.0	0.0000	0	0.00
94 04 01 23	358.0	0.00	294.3	7	976.6	411.3	0.0000	0.0	0.0000	0	0.00
94 04 01 24	5.0	1.54	293.7	7	1010.3	320.0	0.0000	0.0	0.0000	0	0.00

\*\*\* NOTES: STABILITY CLASS 1=A, 2=B, 3=C, 4=D, 5=E AND 6=F.  
FLOW VECTOR IS DIRECTION TOWARD WHICH WIND IS BLOWING.

\*\*\* ISCST3 - VERSION 02035 \*\*\* MULTIPLE POINT SOURCE ISCST3 MODEL  
\*\*\* 06/07/07 \*\*\* ENGRO CHEMICALS (DHARAKI) SINDH

\*\*\* 12:41:07

\*\*MODELOPTs:

PAGE 11

CONC

RURAL FLAT FLGPOL

MSGPRO

\*\*\* THE PERIOD ( 9480 HRS) AVERAGE CONCENTRATION VALUES FOR SOURCE

GROUP: ALL

\*\*\*

INCLUDING SOURCE(S):

STACK1 ,

\*\*\* NETWORK ID: PLANT ; NETWORK TYPE: GRIDCART \*\*\*

\*\* CONC OF NOX

IN MICROGRAMS/M\*\*3

\*\*

Y-COORD (METERS)	X-COORD (METERS)					
	2313062.25	2313562.25	2314062.25	2314562.25	2315062.25	2315562.25
2316062.25	2316562.25	2317062.25				
1152099.38	0.90620	1.77096	1.79918	1.20882	0.35327	0.09846
0.04459	0.10015	0.47814				
1151599.38	0.30784	1.01680	2.01189	1.91609	0.96956	0.23097
0.06567	0.07903	0.38927				
1151099.38	0.11085	0.31660	1.15498	2.29869	1.99425	0.66707
0.13967	0.06956	0.30647				
1150599.38	0.04365	0.10518	0.32462	1.33293	2.63922	1.92701
0.41277	0.09107	0.23085				
1150099.38	0.01575	0.03730	0.09768	0.33120	1.57135	3.04110
1.54662	0.22563	0.16920				
1149599.38	0.00555	0.01154	0.02973	0.08755	0.33526	1.90738
3.49872	0.96431	0.16146				
1149099.38	0.00716	0.00602	0.00843	0.02135	0.07337	0.33480
2.41383	3.87409	0.47076				
1148599.38	0.02858	0.02089	0.01437	0.01049	0.01461	0.05350
0.32359	3.26114	3.47511				
1148099.38	0.14119	0.11206	0.08590	0.06258	0.04168	0.02550
0.03307	0.27484	4.96928				
1147599.38	0.86104	0.82281	0.76173	0.67407	0.55892	0.42345
0.28615	0.15747	0.16282				
1147099.38	1.33504	1.48462	1.66892	1.89955	2.19864	2.59286
3.16474	4.04512	5.73064				
1146599.38	0.59999	0.55860	0.50408	0.43927	0.36745	0.29174
0.22082	0.23875	2.25831				
1146099.38	0.09209	0.07529	0.06048	0.05032	0.05493	0.12481
0.63238	5.00911	7.17281				
1145599.38	0.02354	0.02529	0.03889	0.09036	0.29886	1.37866
5.18719	4.44419	0.35040				
1145099.38	0.03359	0.07050	0.18046	0.57762	2.10276	4.33452
3.14181	0.43627	0.04866				
1144599.38	0.12471	0.31489	0.92677	2.45805	3.51143	2.40320
0.47086	0.06644	0.06128				
1144099.38	0.49090	1.27264	2.43080	2.87943	1.93417	0.48128
0.09384	0.02110	0.11758				
1143599.38	1.50822	2.24217	2.40827	1.61243	0.47815	0.11595
0.02657	0.02164	0.19686				

1143099.38		2.02245	2.05215	1.37895	0.46757	0.13316	0.03717
0.01201	0.03462	0.29777					
1142599.38		1.77669	1.20199	0.45319	0.14667	0.04767	0.01437
0.01134	0.05446	0.42150					
1142099.38		1.06328	0.43712	0.15718	0.05705	0.01941	0.00783
0.01581	0.08012	0.56530					

\*\*\* ISCST3 - VERSION 02035 \*\*\*  
 \*\*\* 06/07/07 \*\*\*  
 \*\*\* ENGRO CHEMICALS (DHARAKI) SINDH \*\*\*

\*\*\* 12:41:07  
 \*\*MODELOPTs:  
 PAGE 12

...  
 ...  
 \*\*MODELOPTs:  
 PAGE 51

CONC RURAL FLAT FLGPOL MSGPRO

\*\*\* Message Summary : ISCST3 Model Execution \*\*\*

----- Summary of Total Messages -----  
 A Total of 0 Fatal Error Message(s)  
 A Total of 83 Warning Message(s)  
 A Total of 5889 Informational Message(s)  
 A Total of 5865 Calm Hours Identified  
 A Total of 24 Missing Hours Identified

\*\*\*\*\* FATAL ERROR MESSAGES \*\*\*\*\*  
 \*\*\* NONE \*\*\*

\*\*\*\*\* WARNING MESSAGES \*\*\*\*\*

MX W430	1595	METQA	:Ambient Temperature Data Out-of-Range.	KURDAT=	94060611
MX W430	1596	METQA	:Ambient Temperature Data Out-of-Range.	KURDAT=	94060612
MX W430	1615	METQA	:Ambient Temperature Data Out-of-Range.	KURDAT=	94060707
MX W430	1616	METQA	:Ambient Temperature Data Out-of-Range.	KURDAT=	94060708
MX W430	1617	METQA	:Ambient Temperature Data Out-of-Range.	KURDAT=	94060709
MX W430	1618	METQA	:Ambient Temperature Data Out-of-Range.	KURDAT=	94060710
MX W430	1619	METQA	:Ambient Temperature Data Out-of-Range.	KURDAT=	94060711
MX W430	1620	METQA	:Ambient Temperature Data Out-of-Range.	KURDAT=	94060712
MX W430	1882	METQA	:Ambient Temperature Data Out-of-Range.	KURDAT=	94061810
MX W430	1883	METQA	:Ambient Temperature Data Out-of-Range.	KURDAT=	94061811
MX W430	1884	METQA	:Ambient Temperature Data Out-of-Range.	KURDAT=	94061812
MX W410	3735	METQA	:Flow Vector Out-of-Range.	KURDAT=	94090315
MX W420	3735	METQA	:Wind Speed Out-of-Range.	KURDAT=	94090315
MX W430	3735	METQA	:Ambient Temperature Data Out-of-Range.	KURDAT=	94090315
MX W410	3736	METQA	:Flow Vector Out-of-Range.	KURDAT=	94090316
MX W420	3736	METQA	:Wind Speed Out-of-Range.	KURDAT=	94090316
MX W430	3736	METQA	:Ambient Temperature Data Out-of-Range.	KURDAT=	94090316
MX W410	3737	METQA	:Flow Vector Out-of-Range.	KURDAT=	94090317
MX W420	3737	METQA	:Wind Speed Out-of-Range.	KURDAT=	94090317
MX W430	3737	METQA	:Ambient Temperature Data Out-of-Range.	KURDAT=	94090317
MX W410	3738	METQA	:Flow Vector Out-of-Range.	KURDAT=	94090318
MX W420	3738	METQA	:Wind Speed Out-of-Range.	KURDAT=	94090318
MX W430	3738	METQA	:Ambient Temperature Data Out-of-Range.	KURDAT=	94090318
MX W410	3739	METQA	:Flow Vector Out-of-Range.	KURDAT=	94090319
MX W420	3739	METQA	:Wind Speed Out-of-Range.	KURDAT=	94090319
MX W430	3739	METQA	:Ambient Temperature Data Out-of-Range.	KURDAT=	94090319
MX W410	3740	METQA	:Flow Vector Out-of-Range.	KURDAT=	94090320
MX W420	3740	METQA	:Wind Speed Out-of-Range.	KURDAT=	94090320
MX W430	3740	METQA	:Ambient Temperature Data Out-of-Range.	KURDAT=	94090320
MX W410	3741	METQA	:Flow Vector Out-of-Range.	KURDAT=	94090321
MX W420	3741	METQA	:Wind Speed Out-of-Range.	KURDAT=	94090321
MX W430	3741	METQA	:Ambient Temperature Data Out-of-Range.	KURDAT=	94090321
MX W410	3742	METQA	:Flow Vector Out-of-Range.	KURDAT=	94090322
MX W420	3742	METQA	:Wind Speed Out-of-Range.	KURDAT=	94090322
MX W430	3742	METQA	:Ambient Temperature Data Out-of-Range.	KURDAT=	94090322
MX W410	3743	METQA	:Flow Vector Out-of-Range.	KURDAT=	94090323
MX W420	3743	METQA	:Wind Speed Out-of-Range.	KURDAT=	94090323
MX W430	3743	METQA	:Ambient Temperature Data Out-of-Range.	KURDAT=	94090323
MX W410	3888	METQA	:Flow Vector Out-of-Range.	KURDAT=	94090924
MX W420	3888	METQA	:Wind Speed Out-of-Range.	KURDAT=	94090924
MX W430	3888	METQA	:Ambient Temperature Data Out-of-Range.	KURDAT=	94090924
MX W410	3889	METQA	:Flow Vector Out-of-Range.	KURDAT=	94091001
MX W420	3889	METQA	:Wind Speed Out-of-Range.	KURDAT=	94091001
MX W430	3889	METQA	:Ambient Temperature Data Out-of-Range.	KURDAT=	94091001

MX W410 3890 METQA :Flow Vector Out-of-Range. KURDAT= 94091002  
MX W420 3890 METQA :Wind Speed Out-of-Range. KURDAT= 94091002  
MX W430 3890 METQA :Ambient Temperature Data Out-of-Range. KURDAT= 94091002  
MX W410 3891 METQA :Flow Vector Out-of-Range. KURDAT= 94091003  
MX W420 3891 METQA :Wind Speed Out-of-Range. KURDAT= 94091003  
MX W430 3891 METQA :Ambient Temperature Data Out-of-Range. KURDAT= 94091003  
MX W410 3892 METQA :Flow Vector Out-of-Range. KURDAT= 94091004  
MX W420 3892 METQA :Wind Speed Out-of-Range. KURDAT= 94091004  
MX W430 3892 METQA :Ambient Temperature Data Out-of-Range. KURDAT= 94091004  
MX W410 3893 METQA :Flow Vector Out-of-Range. KURDAT= 94091005  
MX W420 3893 METQA :Wind Speed Out-of-Range. KURDAT= 94091005  
MX W430 3893 METQA :Ambient Temperature Data Out-of-Range. KURDAT= 94091005  
MX W410 3894 METQA :Flow Vector Out-of-Range. KURDAT= 94091006  
MX W420 3894 METQA :Wind Speed Out-of-Range. KURDAT= 94091006  
MX W430 3894 METQA :Ambient Temperature Data Out-of-Range. KURDAT= 94091006  
MX W410 3895 METQA :Flow Vector Out-of-Range. KURDAT= 94091007  
MX W420 3895 METQA :Wind Speed Out-of-Range. KURDAT= 94091007  
MX W430 3895 METQA :Ambient Temperature Data Out-of-Range. KURDAT= 94091007  
MX W410 3896 METQA :Flow Vector Out-of-Range. KURDAT= 94091008  
MX W420 3896 METQA :Wind Speed Out-of-Range. KURDAT= 94091008  
MX W430 3896 METQA :Ambient Temperature Data Out-of-Range. KURDAT= 94091008  
MX W410 3897 METQA :Flow Vector Out-of-Range. KURDAT= 94091009  
MX W420 3897 METQA :Wind Speed Out-of-Range. KURDAT= 94091009  
MX W430 3897 METQA :Ambient Temperature Data Out-of-Range. KURDAT= 94091009  
MX W410 3898 METQA :Flow Vector Out-of-Range. KURDAT= 94091010  
MX W420 3898 METQA :Wind Speed Out-of-Range. KURDAT= 94091010  
MX W430 3898 METQA :Ambient Temperature Data Out-of-Range. KURDAT= 94091010  
MX W410 3899 METQA :Flow Vector Out-of-Range. KURDAT= 94091011  
MX W420 3899 METQA :Wind Speed Out-of-Range. KURDAT= 94091011  
MX W430 3899 METQA :Ambient Temperature Data Out-of-Range. KURDAT= 94091011  
MX W410 3900 METQA :Flow Vector Out-of-Range. KURDAT= 94091012  
MX W420 3900 METQA :Wind Speed Out-of-Range. KURDAT= 94091012  
MX W430 3900 METQA :Ambient Temperature Data Out-of-Range. KURDAT= 94091012  
MX W410 3901 METQA :Flow Vector Out-of-Range. KURDAT= 94091013  
MX W420 3901 METQA :Wind Speed Out-of-Range. KURDAT= 94091013  
MX W430 3901 METQA :Ambient Temperature Data Out-of-Range. KURDAT= 94091013  
MX W410 3902 METQA :Flow Vector Out-of-Range. KURDAT= 94091014  
MX W420 3902 METQA :Wind Speed Out-of-Range. KURDAT= 94091014  
MX W430 3902 METQA :Ambient Temperature Data Out-of-Range. KURDAT= 94091014

\*\*\*\*\*  
\*\*\* ISCSST3 Finishes Successfully \*\*\*  
\*\*\*\*\*

```

** To run the example, type:
** ISCST3 TEST-ST.inp  outfil.nam
** The results for this example problem are provided in file L201SOX.out
** CONTROL OPTIONS
CO STARTING
  TITLEONE  MULTIPLE POINT SOURCE ISCST3 MODEL
  TITLETWO  ENGRO CHEMICALS (DHARAKI) SINDH
  MODELOPT  RURAL CONC MSGPRO
  AVERTIME  1 24 MONTH PERIOD
  POLLUTID  SOX
**  RUNORNOT  NOT
  RUNORNOT  RUN
  TERRHGTS  FLAT
  FLAGPOLE  2
  ERRORFIL  ERRORS.OUT
CO FINISHED
** SOURCE OPTIONS
SO STARTING
**          SRCID  SRCTYP      XS          YS          ZS
**          -----  -----  -----  -----  -----
  LOCATION  STACK1  POINT  2318062.3404  1147099.3560  0.0
** Point Source      PTEMIS  STKHGT  STKTMP  STKVEL  STKDIA
** Parameters:
  SRCPARAM  STACK1  3.72    60.66   438    0.277  1.6764
** EMISUNIT
  SRCGROUP  ALL
SO FINISHED
** RECEPTOR OPTIONS
RE STARTING
RE GRIDCART PLANT STA
**          Xinit          Xnum  Xdelta          Yinit          Ynum  Ydelta
**          -----  -----  -----  -----  -----
  XYINC    2313062.3404  21    500    1142099.3560  21    500
  GRIDCART PLANT FLAG 1 21*2
  GRIDCART PLANT FLAG 2 21*2
  GRIDCART PLANT FLAG 3 21*2
  GRIDCART PLANT FLAG 4 21*2
  GRIDCART PLANT FLAG 5 21*2
  GRIDCART PLANT FLAG 6 21*2
  GRIDCART PLANT FLAG 7 21*2
  GRIDCART PLANT FLAG 8 21*2
  GRIDCART PLANT FLAG 9 21*2
  GRIDCART PLANT FLAG 10 21*2
  GRIDCART PLANT FLAG 11 21*2
  GRIDCART PLANT FLAG 12 21*2
  GRIDCART PLANT FLAG 13 21*2
  GRIDCART PLANT FLAG 14 21*2
  GRIDCART PLANT FLAG 15 21*2
  GRIDCART PLANT FLAG 16 21*2
  GRIDCART PLANT FLAG 17 21*2
  GRIDCART PLANT FLAG 18 21*2
  GRIDCART PLANT FLAG 19 21*2
  GRIDCART PLANT FLAG 20 21*2
  GRIDCART PLANT FLAG 21 21*2
  GRIDCART PLANT END
RE FINISHED
** MET OPTIONS
ME STARTING
  INPUTFIL  MULTAN2.ASC
  ANEMHGHT  2
  SURFDATA  41675  1994  MULTAN
  UAIRDATA  41675  1994  MULTAN
**  DAYRANGE  1-10
ME FINISHED
OU STARTING
  RECTABLE  ALLAVE  FIRST-SECOND
  MAXTABLE  ALLAVE  50
**  DAYTABLE  ALLAVE
  MAXIFILE  1 ALL  17347.0  MAXIALL.FIL  25
  POSTFILE  MONTH ALL PLOT PSTMNALL.PLT
  POSTFILE  24 ALL PLOT PST24ALL.FIL

```

```

POSTFILE PERIOD ALL PLOT PSTPEALL.PLT
PLOTFILE MONTH ALL FIRST PLTMNALL.FIL
PLOTFILE 24 ALL FIRST PLT24ALL.PLT
PLOTFILE 1 ALL FIRST PLT1ALL.PLT
** PLOTFILE PERIOD ALL PLTPEALL.FIL
OU FINISHED
*****
*** SETUP Finishes Successfully ***
*****
*** ISCST3 - VERSION 02035 ***      *** MULTIPLE POINT SOURCE ISCST3 MODEL
***      06/07/07                  ***      ENGRO      CHEMICALS      (DHARAKI)      SINDH

***      12:33:53
**MODELOPTs:
PAGE 1
CONC          RURAL FLAT  FLGPOL          MSGPRO
-----
***      MODEL SETUP OPTIONS SUMMARY      ***
-----
**Intermediate Terrain Processing is Selected
**Model Is Setup For Calculation of Average CONCentration Values.
-- SCAVENGING/DEPOSITION LOGIC --
**Model Uses NO DRY DEPLETION.  DDPLETE = F
**Model Uses NO WET DEPLETION.  WDPLETE = F
**NO WET SCAVENGING Data Provided.
**NO GAS DRY DEPOSITION Data Provided.
**Model Does NOT Use GRIDDED TERRAIN Data for Depletion Calculations
**Model Uses RURAL Dispersion.
**Model Uses User-Specified Options:
    1. Final Plume Rise.
    2. Stack-tip Downwash.
    3. Buoyancy-induced Dispersion.
    4. Calms Processing Routine.
    5. Missing Data Processing Routine.
    6. Default Wind Profile Exponents.
    7. Default Vertical Potential Temperature Gradients.
**Model Assumes Receptors on FLAT Terrain.
**Model Accepts FLAGPOLE Receptor Heights.
**Model Calculates 3 Short Term Average(s) of:  1-HR  24-HR  MONTH
and Calculates PERIOD Averages
**This Run Includes:  1 Source(s);  1 Source Group(s); and  441 Receptor(s)
**The Model Assumes A Pollutant Type of:  SOX
**Model Set To Continue RUNNING After the Setup Testing.
**Output Options Selected:
    Model Outputs Tables of PERIOD Averages by Receptor
    Model Outputs Tables of Highest Short Term Values by Receptor (RECTABLE Keyword)
    Model Outputs Tables of Overall Maximum Short Term Values (MAXTABLE Keyword)
    Model Outputs External File(s) of Threshold Violations (MAXIFILE Keyword)
    Model Outputs External File(s) of Concurrent Values for Postprocessing (POSTFILE
Keyword)
    Model Outputs External File(s) of High Values for Plotting (PLOTFILE Keyword)
**NOTE:  The Following Flags May Appear Following CONC Values:  c for Calm Hours
                                                    m for Missing Hours
                                                    b for Both Calm and
Missing Hours
**Misc. Inputs:  Anem. Hgt. (m) = 2.00 ;  Decay Coef. = 0.000 ;  Rot.
Angle = 0.0
Emission Units = GRAMS/SEC ;  Emission
Rate Unit Factor = 0.10000E+07
Output Units = MICROGRAMS/M**3
**Approximate Storage Requirements of Model = 1.3 MB of RAM.
**Input Runstream File:  L201SOX.inp
**Output Print File:  L201SOX.out
**Detailed Error/Message File:  ERRORS.OUT
*** ISCST3 - VERSION 02035 ***      *** MULTIPLE POINT SOURCE ISCST3 MODEL
***      06/07/07                  ***      ENGRO      CHEMICALS      (DHARAKI)      SINDH

***      12:33:53
**MODELOPTs:
PAGE 2
CONC          RURAL FLAT  FLGPOL          MSGPRO
*** POINT SOURCE DATA ***

```



1148099.38		2.00	2.00	2.00	2.00	2.00	2.00
2.00	2.00	2.00	2.00	2.00	2.00	2.00	2.00
1147599.38		2.00	2.00	2.00	2.00	2.00	2.00
2.00	2.00	2.00	2.00	2.00	2.00	2.00	2.00
1147099.38		2.00	2.00	2.00	2.00	2.00	2.00
2.00	2.00	2.00	2.00	2.00	2.00	2.00	2.00
1146599.38		2.00	2.00	2.00	2.00	2.00	2.00
2.00	2.00	2.00	2.00	2.00	2.00	2.00	2.00
1146099.38		2.00	2.00	2.00	2.00	2.00	2.00
2.00	2.00	2.00	2.00	2.00	2.00	2.00	2.00
1145599.38		2.00	2.00	2.00	2.00	2.00	2.00
2.00	2.00	2.00	2.00	2.00	2.00	2.00	2.00
1145099.38		2.00	2.00	2.00	2.00	2.00	2.00
2.00	2.00	2.00	2.00	2.00	2.00	2.00	2.00
1144599.38		2.00	2.00	2.00	2.00	2.00	2.00
2.00	2.00	2.00	2.00	2.00	2.00	2.00	2.00
1144099.38		2.00	2.00	2.00	2.00	2.00	2.00
2.00	2.00	2.00	2.00	2.00	2.00	2.00	2.00
1143599.38		2.00	2.00	2.00	2.00	2.00	2.00
2.00	2.00	2.00	2.00	2.00	2.00	2.00	2.00
1143099.38		2.00	2.00	2.00	2.00	2.00	2.00
2.00	2.00	2.00	2.00	2.00	2.00	2.00	2.00
1142599.38		2.00	2.00	2.00	2.00	2.00	2.00
2.00	2.00	2.00	2.00	2.00	2.00	2.00	2.00
1142099.38		2.00	2.00	2.00	2.00	2.00	2.00
2.00	2.00	2.00	2.00	2.00	2.00	2.00	2.00

\*\*\* ISCST3 - VERSION 02035 \*\*\* \*\* MULTIPLE POINT SOURCE ISCST3 MODEL  
 \*\*\* 06/07/07

\*\*\* ENGRO CHEMICALS (DHARAKI) SINDH

\*\*\* 12:33:53

\*\*MODELOPTs:

PAGE 6

CONC

RURAL FLAT FLGPOL

MSGPRO

\*\*\* NETWORK ID: PLANT ; NETWORK TYPE: GRIDCART \*\*\*

\* RECEPTOR FLAGPOLE HEIGHTS IN METERS \*

Y-COORD (METERS)		2317562.25	2318062.25	2318562.25	2319062.25	2319562.25
2320062.25		2320562.25	2321062.25	2321562.25		

1152099.38		2.00	2.00	2.00	2.00	2.00
2.00	2.00	2.00	2.00	2.00	2.00	2.00
1151599.38		2.00	2.00	2.00	2.00	2.00
2.00	2.00	2.00	2.00	2.00	2.00	2.00
1151099.38		2.00	2.00	2.00	2.00	2.00
2.00	2.00	2.00	2.00	2.00	2.00	2.00
1150599.38		2.00	2.00	2.00	2.00	2.00
2.00	2.00	2.00	2.00	2.00	2.00	2.00
1150099.38		2.00	2.00	2.00	2.00	2.00
2.00	2.00	2.00	2.00	2.00	2.00	2.00
1149599.38		2.00	2.00	2.00	2.00	2.00
2.00	2.00	2.00	2.00	2.00	2.00	2.00
1149099.38		2.00	2.00	2.00	2.00	2.00
2.00	2.00	2.00	2.00	2.00	2.00	2.00
1148599.38		2.00	2.00	2.00	2.00	2.00
2.00	2.00	2.00	2.00	2.00	2.00	2.00
1148099.38		2.00	2.00	2.00	2.00	2.00
2.00	2.00	2.00	2.00	2.00	2.00	2.00
1147599.38		2.00	2.00	2.00	2.00	2.00
2.00	2.00	2.00	2.00	2.00	2.00	2.00
1147099.38		2.00	2.00	2.00	2.00	2.00
2.00	2.00	2.00	2.00	2.00	2.00	2.00
1146599.38		2.00	2.00	2.00	2.00	2.00
2.00	2.00	2.00	2.00	2.00	2.00	2.00
1146099.38		2.00	2.00	2.00	2.00	2.00
2.00	2.00	2.00	2.00	2.00	2.00	2.00
1145599.38		2.00	2.00	2.00	2.00	2.00
2.00	2.00	2.00	2.00	2.00	2.00	2.00
1145099.38		2.00	2.00	2.00	2.00	2.00
2.00	2.00	2.00	2.00	2.00	2.00	2.00
1144599.38		2.00	2.00	2.00	2.00	2.00
2.00	2.00	2.00	2.00	2.00	2.00	2.00







(METERS)	2313062.25	2313562.25	2314062.25	2314562.25	2315062.25
2315562.25	2316062.25	2316562.25	2317062.25		
1152099.38	0.11417	0.21452	0.22038	0.15038	0.04813
0.01374	0.00624	0.01400	0.06631		
1151599.38	0.04174	0.12727	0.24156	0.23356	0.12329
0.03193	0.00918	0.01105	0.05414		
1151099.38	0.01543	0.04302	0.14354	0.27374	0.24202
0.08847	0.01945	0.00973	0.04271		
1150599.38	0.00610	0.01466	0.04421	0.16444	0.31229
0.23459	0.05648	0.01272	0.03221		
1150099.38	0.00220	0.00522	0.01362	0.04523	0.19244
0.35882	0.19453	0.03130	0.02361		
1149599.38	0.00078	0.00161	0.00416	0.01222	0.04592
0.23194	0.41344	0.12864	0.02250		
1149099.38	0.00100	0.00084	0.00118	0.00298	0.01024
0.04601	0.29210	0.46313	0.06465		
1148599.38	0.00400	0.00292	0.00201	0.00147	0.00204
0.00746	0.04459	0.39508	0.43587		
1148099.38	0.01943	0.01551	0.01194	0.00872	0.00582
0.00356	0.00461	0.03782	0.60614		
1147599.38	0.10763	0.10394	0.09756	0.08769	0.07395
0.05704	0.03915	0.02164	0.02213		
1147099.38	0.16055	0.17721	0.19773	0.22322	0.25657
0.30160	0.36916	0.47816	0.68403		
1146599.38	0.07472	0.07036	0.06457	0.05742	0.04908
0.03970	0.03041	0.03288	0.29621		
1146099.38	0.01274	0.01046	0.00843	0.00702	0.00767
0.01737	0.08662	0.63140	0.88810		
1145599.38	0.00329	0.00354	0.00544	0.01261	0.04138
0.18291	0.64009	0.55633	0.04823		
1145099.38	0.00470	0.00985	0.02509	0.07862	0.26784
0.53717	0.39579	0.06005	0.00678		
1144599.38	0.01738	0.04337	0.12284	0.30746	0.43855
0.30463	0.06466	0.00927	0.00854		
1144099.38	0.06656	0.16426	0.30465	0.36210	0.24666
0.06596	0.01310	0.00295	0.01639		
1143599.38	0.19203	0.28307	0.30473	0.20675	0.06545
0.01618	0.00372	0.00303	0.02741		
1143099.38	0.25719	0.26113	0.17772	0.06394	0.01856
0.00520	0.00168	0.00484	0.04136		
1142599.38	0.22724	0.15565	0.06192	0.02043	0.00667
0.00201	0.00159	0.00761	0.05834		
1142099.38	0.13830	0.05968	0.02188	0.00798	0.00272
0.00110	0.00221	0.01120	0.07790		

\*\*\* ISCST3 - VERSION 02035 \*\*\* MULTIPLE POINT SOURCE ISCST3 MODEL  
 \*\*\* 06/07/07 \*\*\* ENGRO CHEMICALS (DHARAKI) SINDH

\*\*\* 12:33:53

\*\*MODELOPTs:  
 PAGE 12  
 ...

\*\*MODELOPTs:  
 PAGE 51

CONC RURAL FLAT FLGPOL MSGPRO

\*\*\* Message Summary : ISCST3 Model Execution \*\*\*  
 ----- Summary of Total Messages -----  
 A Total of 0 Fatal Error Message(s)  
 A Total of 83 Warning Message(s)  
 A Total of 5889 Informational Message(s)  
 A Total of 5865 Calm Hours Identified  
 A Total of 24 Missing Hours Identified

\*\*\*\*\* FATAL ERROR MESSAGES \*\*\*\*\*  
 \*\*\* NONE \*\*\*

\*\*\*\*\* WARNING MESSAGES \*\*\*\*\*  
 MX W430 1595 METQA :Ambient Temperature Data Out-of-Range. KURDAT= 94060611  
 MX W430 1596 METQA :Ambient Temperature Data Out-of-Range. KURDAT= 94060612  
 MX W430 1615 METQA :Ambient Temperature Data Out-of-Range. KURDAT= 94060707  
 MX W430 1616 METQA :Ambient Temperature Data Out-of-Range. KURDAT= 94060708  
 MX W430 1617 METQA :Ambient Temperature Data Out-of-Range. KURDAT= 94060709



## Appendix G: Accidental Release of Ammonia

### G.1 Brief Description of the Model

1	<b>Abstract of Model Capabilities</b>	AFTOX is a Gaussian dispersion model that is used by the Air Force to calculate toxic corridors in case of accidental releases. It is limited to non-dense gases. It can directly calculate the evaporation rate from liquid spills. AFTOX treats instantaneous or continuous releases from any elevation, and can calculate the rise of buoyant plumes. It is intended to be consistent with the ADAM model for passive (neutrally buoyant) gas releases.
2	<b>Sponsor and/or Developing Organization</b>	Phillips Laboratory Directorate of Geophysics Air Force Systems Command Hanscom AFB, MA 01731-5000
3	<b>Last Custodian/ Point of Contact</b>	Steven Sambol 30 WS/WES Vandenberg AFB, CA 93437-5000 805-734-8232
4	<b>Life-Cycle</b>	AFTOX was developed by the U.S. Air Force in the late 1980s in order to estimate toxic corridors in the case of accidental releases of hazardous chemicals to the atmosphere. AFTOX is intended to be a replacement for the empirical OB/DG model, which was used by the Air Force for similar purposes since the 1960s.
5	<b>Model Description Summary</b>	AFTOX requires input of gas or liquid release amount (for instantaneous sources) or release rate (for continuous sources). It can calculate the evaporation of liquid spills. If the release is positively buoyant, it can calculate the buoyant plume rise. Dense gas effects are not accounted for. Dispersion calculations are carried out with standard Gaussian formulas. Stability class is treated as a continuous variable. Averaging time is accounted for. Outputs include maps of toxic corridors, estimates of concentration at specific positions, and estimates of the magnitude and location of the maximum concentration occurring a certain time after release.
6	<b>Application Limitation</b>	The code calculates evaporative emissions from liquid spills, but has no other capabilities for determining source emissions. Dense gases are not accounted for. Batch runs are difficult to make. Outputs are limited to contour plots and simplified tables.
7	<b>Strengths/ Limitations</b>	<p><b>Strengths:</b> A strength of AFTOX is that it has undergone extensive testing and troubleshooting. The developer, Bruce Kunkel, has made sure that AFTOX and ADAM (valid for dense gases) approach each other in the limit of passive (non-dense) releases. The meteorological processor/stability class estimator represents the state of the art in boundary layer theory. AFTOX allows 90% confidence bounds to be printed out for toxic corridors and concentrations at a point.</p> <p><b>Limitation:</b> The major weakness of AFTOX is that it does not treat dense gases, which are frequently encountered in accidental release scenarios. Also, it would help the user if an algorithm were added to calculate the emission rate from pressurized tank or pipe ruptures. AFTOX could be made more useful by modifying the input and output modules so that batch runs could be made and so that more extensive output files could be printed or plotted.</p>

8	<b>Model References</b>	! Kunkel, B. A., 1991: AFTOX 4.0 — The Air Force Toxic Chemical Dispersion Model — A User's Guide. PL-TR-91-2119, Environmental Research Papers No. 1083, Phillips Laboratory, Directorate of Geophysics, Air Force Systems Command, Hanscom AFB, MA 01731-5000, 62 pages. ! Kunkel, B.A., 1985: Development of an Atmospheric Diffusion Model for Toxic Chemical Releases. AFGL-TR-85-0338, AFGL/AFSC, USAF, Hanscom AFB, MA 01731-5000. ! Kunkel, B.A., 1988: User's Guide for the Air Force Toxic Chemical Dispersion Model (AFTOX). AFGL-TR-88-0009, AFGL/AFSC, USAF, Hanscom AFB, MA 01731-5000.
9	<b>Input Data/Parameter Requirements</b>	The user must specify the site and time information, chemical information, release information, ground conditions, atmospheric conditions, and output options in order to make a model run. The chemical database for AFTOX contains properties for roughly 80 chemicals. The specification of the source strength is mandatory for all releases, except for a continuous liquid spill where the evaporation rate can be estimated by the model. By default, AFTOX determines atmospheric stability using Golder's nomogram, based on the surface roughness specified by the user and the Monin-Obukhov length internally calculated by the model. If the standard deviation of wind direction is known and is provided as an input, AFTOX will use it to determine atmospheric stability. (The same procedure is also used in the ADAM model to determine atmospheric stability.) One deficiency with the input structure for AFTOX is that the user cannot save the input data for a case so that it can be rerun later on.
10	<b>Output Summary</b>	The output generated by the AFTOX model includes three options: (1) concentration contours on the computer screen for up to three user-defined concentration values, (2) concentration at a specified location and time, and (3) maximum concentration at a specified elevation and time. For option (2), the user must specify the receptor locations one at a time. That is, AFTOX does not automatically generate a distribution (or table) of predicted concentrations with downwind distance. For option (3), AFTOX will calculate the location of the maximum concentration for a given elevation and elapsed time.
11	<b>Applications</b>	See item 8 above. Also, Hanna et al. (1993) included AFTOX in their comprehensive exercise in which 15 models were evaluated using field data from eight sites (see number 19 below).
12	<b>User-Friendliness</b>	The AFTOX model has a text-based interactive user interface, where the user is prompted with a series of questions in order to define a scenario. The user needs to further decide an output option (see number 10 above) before the model performs any calculations. Due to the interactive nature of its input structure, AFTOX can be considered as user friendly in that the user seldom needs to consult the user's manual. However, it is a tedious task to obtain predicted concentrations at a series of downwind distances, since, as mentioned in number 10 above, the user can specify receptor locations only one at a time. Furthermore, AFTOX does not allow the user to save the input data for one case for later use for other cases. Therefore, if it is necessary to run the same case again, all information will have to be entered again.

13 <b>Hardware-Software Interface Constraints/ Requirements</b>	Computer operating system: The AFTOX model runs in the MS-DOS environment. Computer platform: Disk space requirements: A minimum of less than 1 MB. Run execution time (for a typical problem): The model takes only a few seconds to run on a Pentium PC for a typical scenario. Programming language: Both the computational and graphical output portions of the code are written in Zenith BASIC (ZBASIC), which is specific to PCS. Other computer peripheral information: AFTOX cannot be directly ported to other computer platforms. The model does not interface with other codes; however, the ADAM dense gas code has been designed to reduce to AFTOX in the passive gas limit (both models were developed for the U.S. Air Force).
14 <b>Operational Parameters</b>	Identify whether the code has any error diagnostic messages to assist the user in troubleshooting operational problems: The AFTOX model validates some, but not all, input parameters that the user specifies from the keyboard. The user will be asked to reenter the value for a variable if that value is found to be out of range. The model has no runtime error diagnostics. However, since simple Gaussian-type dispersion algorithms are used, the code is quite robust and rarely encounters numerical difficulties. Set up time for: Requires minimal initial setup. After the model files are copied onto a computer's hard disk, the user simply types "AFTOX" to run the model.
15 <b>Surety Considerations</b>	All quality assurance documentation: No information provided. Benchmark runs: No information provided. Validation calculations: No information provided. Verification with field experiments that has been performed with respect to this code: AFTOX was included in the comprehensive model evaluation exercise reported by Hanna et al. (1993). Since AFTOX does not treat the dispersion of denser-than-air gases, the model was mainly evaluated using the Prairie Grass and Hanford field experiments where the releases were neutrally buoyant. In general, AFTOX overpredicted the observed concentrations by a small amount (less than a factor of 2).
16 <b>Runtime Characteristics</b>	The AFTOX model is intended to be run in interactive mode, where the user is prompted with a series of questions during the runtime. However, if the user is very familiar with the input requirements for AFTOX, it is possible to run the model in batch mode using the feature of input-redirection, i.e., redirecting the keyboard input to a file, available in MS-DOS.

## G.2 Meteorology Conditions

Condition No.	Month	Time	Surface Roughness height (m)	Ambient measurement height (m)	Ambient wind speed (m/s)	Ambient Temperature (K)	Relative Humidity (%)
1.	June	Day	0.04	7.0	2.21	316.6	35.0
2.	June	Day	0.04	7.0	2.21	316.6	35.0
3.	June	Day	0.04	7.0	2.21	316.6	35.0
4.	June	Day	0.04	7.0	2.21	316.6	35.0
5.	June	Day	0.04	7.0	2.21	316.6	35.0

**G.3 Case Definition**

Case No.	Gas	Location	Meteorological Condition
1.	Ammonia	Ammonia KO Drum	1
2.	Ammonia	Ammonia Flash Vessel	1
3.	Ammonia	Ammonia Flash Vessel (Second)	2
4.	Ammonia	Ammonia Accumulator	2
5.	Ammonia	Ammonia Receiver	2
6.	Ammonia	Ammonia Storage Tank	2

**G.4 Results**

**G.4.1 Case 1 (Ammonia KO Drum)**

**Input Parameters**

CONTINUOUS RELEASE

AMMONIA  
EXPOSURE LIMITS AVAILABLE AT THIS TIME

TEMPERATURE = 43.6 C  
WIND DIRECTION = 122  
WIND SPEED = 2.21 M/S  
DAYTIME SPILL  
CLOUD COVER IS 2 EIGHTHS  
GROUND IS DRY  
THERE IS NO INVERSION  
ATMOSPHERIC STABILITY PARAMETER IS 3.55  
SPILL SITE ROUGHNESS LENGTH IS 10 CM

THIS IS A GAS RELEASE  
HEIGHT OF LEAK ABOVE GROUND IS 3 M  
EMISSION RATE IS 6.24 KG/MIN  
ELAPSED TIME OF SPILL IS 1440 MIN  
TOTAL AMOUNT SPILLED IS 8985 KG  
CONCENTRATION AVERAGING TIME IS 15 MIN  
ELAPSED TIME SINCE START OF SPILL IS 1440 MIN  
HEIGHT OF INTEREST IS 2 M

**Results**

Concentration (ppm)	Maximum Distance (m)
50	391

Toxic Corridor Length: 821 meters  
Direction and Width : 302 +/- 45 DEG

## G.4.2 Case 2 (Ammonia Flash Vessel)

### Input Parameters

CONTINUOUS RELEASE

AMMONIA

EXPOSURE LIMITS AVAILABLE AT THIS TIME

TEMPERATURE = 43.6 C  
 WIND DIRECTION = 122  
 WIND SPEED = 2.21 M/S  
 DAYTIME SPILL  
 CLOUD COVER IS 2 EIGHTHS  
 GROUND IS DRY  
 THERE IS NO INVERSION  
 ATMOSPHERIC STABILITY PARAMETER IS 3.55  
 SPILL SITE ROUGHNESS LENGTH IS 10 CM

THIS IS A GAS RELEASE  
 HEIGHT OF LEAK ABOVE GROUND IS 3 M  
 EMISSION RATE IS 10.33 KG/MIN  
 ELAPSED TIME OF SPILL IS 1440 MIN  
 TOTAL AMOUNT SPILLED IS 14,875 KG  
 CONCENTRATION AVERAGING TIME IS 15 MIN  
 ELAPSED TIME SINCE START OF SPILL IS 1440 MIN  
 HEIGHT OF INTEREST IS 2 M

### Results

<i>Concentration (ppm)</i>	<i>Maximum Distance (m)</i>
50	538

Toxic Corridor Length: 1130 meters  
 Direction and Width : 302 +/- 68 DEG

## G.4.3 Case 3 (Ammonia Flash Vessel (Second))

### Input Parameters

CONTINUOUS RELEASE

AMMONIA

EXPOSURE LIMITS AVAILABLE AT THIS TIME

TEMPERATURE = 43.6 C  
 WIND DIRECTION = 122  
 WIND SPEED = 2.21 M/S  
 DAYTIME SPILL  
 CLOUD COVER IS 2 EIGHTHS  
 GROUND IS DRY  
 THERE IS NO INVERSION  
 ATMOSPHERIC STABILITY PARAMETER IS 3.55  
 SPILL SITE ROUGHNESS LENGTH IS 10 CM

THIS IS A GAS RELEASE  
 HEIGHT OF LEAK ABOVE GROUND IS 3 M  
 EMISSION RATE IS 8.79 KG/MIN  
 ELAPSED TIME OF SPILL IS 720 MIN  
 TOTAL AMOUNT SPILLED IS 6328 KG  
 CONCENTRATION AVERAGING TIME IS 15 MIN  
 ELAPSED TIME SINCE START OF SPILL IS 720 MIN  
 HEIGHT OF INTEREST IS 2 M

**Results**

<i>Concentration (ppm)</i>	<i>Maximum Distance (m)</i>
50	485

Toxic Corridor Length: 1020 meters  
 Direction and Width : 302 +/- 68 DEG

**G.4.4 Case 4 (Ammonia Accumulator)**

**Input Parameters**

CONTINUOUS RELEASE

AMMONIA  
 EXPOSURE LIMITS AVAILABLE AT THIS TIME

TEMPERATURE = 43.6 C  
 WIND DIRECTION = 122  
 WIND SPEED = 2.21 M/S  
 DAYTIME SPILL  
 CLOUD COVER IS 2 EIGHTHS  
 GROUND IS DRY  
 THERE IS NO INVERSION  
 ATMOSPHERIC STABILITY PARAMETER IS 3.55  
 SPILL SITE ROUGHNESS LENGTH IS 10 CM

THIS IS A GAS RELEASE  
 HEIGHT OF LEAK ABOVE GROUND IS 3 M  
 EMISSION RATE IS 11.12 KG/MIN  
 ELAPSED TIME OF SPILL IS 1440 MIN  
 TOTAL AMOUNT SPILLED IS 16,012 KG  
 CONCENTRATION AVERAGING TIME IS 15 MIN  
 ELAPSED TIME SINCE START OF SPILL IS 1440 MIN  
 HEIGHT OF INTEREST IS 2 M

**Results**

<i>Concentration (ppm)</i>	<i>Maximum Distance (m)</i>
50	563

Toxic Corridor Length: 1180 meters  
 Direction and Width : 302 +/- 68 DEG

**G.4.5 Case 5 (Ammonia Receiver)**

**Input Parameters**

CONTINUOUS RELEASE

AMMONIA  
 EXPOSURE LIMITS AVAILABLE AT THIS TIME

TEMPERATURE = 43.6 C  
 WIND DIRECTION = 122  
 WIND SPEED = 2.21 M/S  
 DAYTIME SPILL  
 CLOUD COVER IS 2 EIGHTHS

GROUND IS DRY  
 THERE IS NO INVERSION  
 ATMOSPHERIC STABILITY PARAMETER IS 3.55  
 SPILL SITE ROUGHNESS LENGTH IS 10 CM

THIS IS A GAS RELEASE  
 HEIGHT OF LEAK ABOVE GROUND IS 3 M  
 EMISSION RATE IS 41.26 KG/MIN  
 ELAPSED TIME OF SPILL IS 1440 MIN  
 TOTAL AMOUNT SPILLED IS 59,414 KG  
 CONCENTRATION AVERAGING TIME IS 15 MIN  
 ELAPSED TIME SINCE START OF SPILL IS 1440 MIN  
 HEIGHT OF INTEREST IS 2 M

**Results**

<i>Concentration (ppm)</i>	<i>Maximum Distance (m)</i>
50	1,240

Toxic Corridor Length: 2610 meters  
 Direction and Width : 302 +/- 68 DEG

**G.4.6 Case 6 (Ammonia Storage Tank)**

**Input Parameters**

CONTINUOUS RELEASE

AMMONIA  
 EXPOSURE LIMITS AVAILABLE AT THIS TIME

TEMPERATURE = 43.6 C  
 WIND DIRECTION = 122  
 WIND SPEED = 2.21 M/S  
 DAYTIME SPILL  
 CLOUD COVER IS 2 EIGHTHS  
 GROUND IS DRY  
 THERE IS NO INVERSION  
 ATMOSPHERIC STABILITY PARAMETER IS 3.55  
 SPILL SITE ROUGHNESS LENGTH IS 10 CM

THIS IS A GAS RELEASE  
 HEIGHT OF LEAK ABOVE GROUND IS 3 M  
 EMISSION RATE IS 1041.7 KG/MIN  
 ELAPSED TIME OF SPILL IS 1440 MIN  
 TOTAL AMOUNT SPILLED IS 15,00,000 KG  
 CONCENTRATION AVERAGING TIME IS 15 MIN  
 ELAPSED TIME SINCE START OF SPILL IS 1440 MIN  
 HEIGHT OF INTEREST IS 2 M

**Results**

<i>Concentration (ppm)</i>	<i>Maximum Distance (m)</i>
50	5,270

Toxic Corridor Length: 11,280 meters  
 Direction and Width : 302 +/- 31 DEG