

Annex M

## Risk and Disaster Management Plan

Sembcorp Industries Limited

Risk & Disaster Management Plan  
for a green-field Combined Cycle  
Gas Turbine Power Plant in  
Myingyan, Myanmar

August 2015

Reference: 0284993

**Environmental Resources Management**

16/F Berkshire House  
25 Westlands Road  
Quarry Bay, Hong Kong  
Telephone: (852) 2271 3000  
Facsimile: (852) 2723 5660  
E-mail: [post.hk@erm.com](mailto:post.hk@erm.com)  
<http://www.erm.com>

Sembcorp Industries Limited

Risk & Disaster Management Plan  
for a green-field Combined Cycle  
Gas Turbine Power Plant in  
Myingyan, Myanmar

August 2015

Reference 0284993

Prepared by: Adrien Au-Yeung/ Thomas Wu

Checked by: Kim Tran

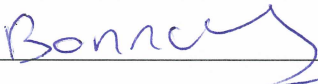
For and on behalf of ERM-Hong Kong, Limited
Approved by: _____ Herve Bonnel
Signed: _____ 
Position: _____ Partner
Date: _____ 28 August 2015

This report has been prepared by ERM-Hong Kong, Limited with all reasonable skill, care and diligence within the terms of the Contract with the client, incorporating our General Terms and Conditions of Business and taking account of the resources devoted to it by agreement with the client.

We disclaim any responsibility to the client and others in respect of any matters outside the scope of the above.

This report is confidential to the client and we accept no responsibility of whatsoever nature to third parties to whom this report, or any part thereof, is made known. Any such party relies on the report at their own risk.

## CONTENTS

	<i>EXECUTIVE SUMMARY</i>	<i>i</i>
<b>1</b>	<b><i>INTRODUCTION</i></b>	<b>1</b>
1.1	<i>BACKGROUND</i>	1
1.2	<i>BASIS OF THE REPORT</i>	2
1.3	<i>APPROACH</i>	2
1.4	<i>STUDY BASIS</i>	3
<b>2</b>	<b><i>ABBREVIATIONS</i></b>	<b>6</b>
<b>3</b>	<b><i>OVERVIEW OF THE SEMBCORP GAS-FIRED CCGT POWER POINT</i></b>	<b>7</b>
3.1	<i>PROJECT LOCATION AND SURROUNDING ENVIRONMENT</i>	7
3.2	<i>PROJECT FACILITIES AND ASSOCIATED FACILITIES</i>	10
3.3	<i>PROJECT LIFE CYCLE</i>	17
3.4	<i>DANGEROUS SUBSTANCES IN USE</i>	24
3.5	<i>ORGANISATION AND MANAGEMENT STRUCTURE OF SEMBCORP GAS-FIRED CCGT POWER PLANT</i>	25
<b>4</b>	<b><i>POTENTIAL MAJOR ACCIDENT HAZARDS SCENARIOS</i></b>	<b>27</b>
4.1	<i>ON-SITE MAJOR ACCIDENT HAZARDS</i>	27
4.2	<i>EXTERNAL HAZARDS</i>	31
4.3	<i>METHODOLOGY FOR IDENTIFYING HAZARDS AND GENERATING SCENARIOS</i>	33
4.4	<i>ASSESSMENT OF MAJOR ACCIDENT SCENARIOS</i>	34
<b>5</b>	<b><i>MAJOR ACCIDENT PREVENT POLICY AND SAFETY MANAGEMENT SYSTEM</i></b>	<b>35</b>
5.1	<i>MAJOR ACCIDENT PREVENTION POLICY REVIEW</i>	35
5.2	<i>SAFETY MANAGEMENT SYSTEM</i>	38
5.3	<i>PROJECT HSE PLAN</i>	41
5.4	<i>MEASURES TO PREVENT ACCIDENTS OR LIMIT THE CONSEQUENCES OF A MAJOR ACCIDENT</i>	51
<b>6</b>	<b><i>COMMUNICATIONS AND EMERGENCY SYSTEM</i></b>	<b>53</b>
6.1	<i>COMMUNICATION</i>	53
6.2	<i>EMERGENCY PLAN</i>	55
<b>7</b>	<b><i>CONCLUSIONS AND RECOMMENDATIONS</i></b>	<b>65</b>
7.1	<i>CONCLUSIONS</i>	65

7.2	<i>RECOMMENDATIONS</i>	65
	<i>REFERENCES</i>	67
	<i>APPENDIX A QRA INPUT DATA</i>	
	<i>APPENDIX B QRA RECOMMENDATIONS</i>	

## *EXECUTIVE SUMMARY*

Sembcorp Industries Limited (Sembcorp) has been selected by the Ministry of Electric Power (MOEP) of the Government of Myanmar (GOM) as a private sector Independent Power Producer (IPP) to develop a 225 MW Combined Cycle Gas Turbine (CCGT) Power Plant on a Build, Operate and Transfer (BOT) basis in Myingyan Township, in the Mandalay region in Union Republic of Myanmar.

The Project Site is located approximately 8 km south of the Myingyan Township, on a predominately green field site adjacent to an existing steel mill (Myingyan Steel Mill No. 4) owned by the Ministry of Industry (MOI).

The Project Site was acquired by the GOM and the registered land owner is MOI. The Majority of this MOI-owned land is occupied by the existing steel mill infrastructure which was commissioned in 2007. The northern part was allocated for the Power Plant

Environmental Resources Management (ERM), and independent HSE consultancy, has been commissioned by Sembcorp to carry out an ESIA Study for the proposed CCGT Power Plant and relevant Project Facilities. This report presents the Risk and Disaster Management Plan (RDMP).

The Project will invest and establish an efficient form of CCGT Power Plant which was designed for high reliability and efficient operation with lower environmental impact, operating with Natural Gas as its only fuel. Project Facilities include:

- 225 MW CCGT Power Plant;
- Gas Supply Pipeline;
- 230 kV Overhead Transmission Line; and
- Water Supply Pipeline, Wastewater Discharge Pipeline and Water Intake Pumping Station.

There is also an existing 95 MW temporary Gas-fired Power Plant located within the Project Site boundary operated by Aggreko. The temporary Gas-fired Power Plant comprises of 92 gas engines rated at 1.3 MW each (119 MW in total), and the generated power is supplied to the Myingyan Township via the existing 132 kV Overhead Transmission Line. The temporary Gas-fired Power Plant will be decommissioned once the new CCGT Power Plant is in operation.

The purpose of the report is a document prepared by the operator with a management plan to

1. demonstrate that accident prevention policy has been provided and a safety management system has been put in place to implement the policy;

2. demonstrate that major accident hazards have been identified and that the necessary measures have been taken to prevent such accidents and to limit their consequences;
3. demonstrate that safety and reliability have been incorporated into the design & construction, operation & maintenance of those installations related to its operation, and which are linked to major accident hazards within the management plan; and
4. demonstrate that emergency plans have been draw up and that the operator is supplying information to enable the off-site plan to be drawn up in order to take the necessary measures in the event of a major accident.

This Risk and Disaster Management Plan identified and highlighted the potential risks associated with the natural gas (Fuel Gas), the risk mitigation and management techniques and the systems that are in place to control and manage the installations in the safe way. The risks of the fuel gas facilities were evaluated both qualitatively and quantitatively by ERM with the results included in this report.

The following conclusions are made in this Risk and Disaster Management Plan:

#### *Conclusions*

A major accident prevention policy has been provided and a safety management system has been put in place to implement the policy. As the CCGT Power Plant project is in the preliminary design stage, preliminary hazard identification has been performed on the power plant. Studies such as HAZID, HAZOP and QRA studies will be performed as the project proceeds into the EPC stage. Some measures have been put in place to minimize the risk of hazardous events; general recommendations have been made to further supplement the measures currently considered. Safety and reliability have been considered in the design, construction, operation and maintenance of the CCGT power plant. Emergency plans have been developed as detailed in project documents and some recommendations have been made to the plans.

#### *Recommendations*

Recommendation 1: all pipes and equipment should be suitably coated against external corrosion. Also, lagging should be provided with removable panel to facilitate routine inspection of the condition of the pipework surface. (Refer to *section 4.1.1*)

Recommendation 2: Area around the gas supply pipeline and valve stations should be zone-classified and access-controlled to eliminate any source of ignition. (Refer to *section 4.1.1*)

Recommendation 3: Consider implementing a HEMP (Hazard and Effects Management Process) to identify and manage the major accidental hazards. (Refer to *section 4.1.1*)

Recommendation 4: a Quantitative Risk Assessment (QRA) needs to be performed during EPC stage for the Power Plant in order to evaluate the risk due to the explosion events to the On-site, Off-site population as well as the adjacent facilities. The Emergency Response Plan needs to be updated in order to take into account these explosion events. (Refer to *section 4.1.2*)

Recommendation 5: a HAZID for commissioning/ start-up can be performed during EPC stage in order to identify all potential risk due to these operations. (Refer to *section 4.1.2*)

Recommendation 6: Layout study should be conducted to assess adequacy of separation distances from major hazard installations to sensitive equipments, buildings and emergency assembly area locations. (Refer to *section 4.1.3*)

Recommendation 7: Comprehensive soil investigation survey is recommended to investigate ground settlement / subsidence risk. (Refer to *section 4.2.4*)

Recommendation 8: The design of the Power Plant should be such that the impacts due to severe earthquakes are minimized. (Refer to *section 4.2.5*)

Recommendation 9: Ensure sufficient coverage of Fire & Gas Detectors. Ensure sufficient coverage of fire fighting system such as hydrants, monitors, etc. (Refer to *section 6.2.2* and *6.2.5*)

Recommendation 10: Primary emergency communication system should be available with emergency response teams and local authority personnel involved with emergency response. Secondary / alternative emergency communication system should also be available for emergency response. (Refer to *section 6.2.8*)

Recommendation 11: Safety and reliability of the CCGT power plant should be review regularly during the design, construction, and operational phases.

**BACKGROUND**

Sembcorp Industries Limited (Sembcorp) has been selected by the Ministry of Electric Power (MOEP) of the Government of Myanmar (GOM) as a private sector Independent Power Producer (IPP) to develop a 225 MW Combined Cycle Gas Turbine (CCGT) Power Plant on a Build, Operate and Transfer (BOT) basis in Myingyan Township, in the Mandalay region in Union Republic of Myanmar.

The Project Site is located approximately 8 km south of the Myingyan Township, on a predominately green field site adjacent to an existing steel mill (Myingyan Steel Mill No. 4) owned by the Ministry of Industry (MOI).

The Project Site was acquired by the GOM and the registered land owner is MOI. The Majority of this MOI-owned land is occupied by the existing steel mill infrastructure which was commissioned in 2007. The northern part was allocated for the Power Plant

Environmental Resources Management (ERM), and independent HSE consultancy, has been commissioned by Sembcorp to carry out an ESIA Study for the proposed CCGT Power Plant and relevant Project Facilities. This report presents the Risk and Disaster Management Plan (RDMP).

**Brief Facility Description**

The Project will invest and establish an efficient form of CCGT Power Plant which was designed for high reliability and efficient operation with lower environmental impact, operating with Natural Gas as its only fuel. Project Facilities include:

- 225 MW CCGT Power Plant;
- Gas Supply Pipeline;
- 230 kV Overhead Transmission Line; and
- Water Supply Pipeline, Wastewater Discharge Pipeline and Water Intake Pumping Station.

Details of Project Facilities are provided in *Section 3*.

There is also an existing 95 MW temporary Gas-fired Power Plant located within the Project Site boundary operated by Aggreko. The temporary Gas-fired Power Plant comprises of 92 gas engines rated at 1.3 MW each (119 MW in total), and the generated power is supplied is supplied to the Myingyan Township via the existing 132 kV Overhead Transmission Line. The temporary Gas-fired Power Plant will be decommissioned once the new CCGT Power Plant is in operation.

The project site location and a Layout of the Project Facilities are provided in *Figure 1.1* and *Figure 1.2*.

## **1.2 BASIS OF THE REPORT**

This Risk and Disaster Management Plan is written for the new CCGT Power Plant. This report has been prepared in accordance with “The Control of Major Accident Hazards Regulations 1999” (UK). The purpose of the report is a document prepared by the operator with a management plan to

1. demonstrate that accident prevention policy has been provided and a safety management system has been put in place to implement the policy;
2. demonstrate that major accident hazards have been identified and that the necessary measures have been taken to prevent such accidents and to limit their consequences;
3. demonstrate that safety and reliability have been incorporated into the design & construction, operation & maintenance of those installations related to its operation, and which are linked to major accident hazards within the management plan; and
4. demonstrate that emergency plans have been draw up and that the operator is supplying information to enable the off-site plan to be drawn up in order to take the necessary measures in the event of a major accident.

This Risk and Disaster Management Plan identified and highlighted the potential risks associated with the natural gas (Fuel Gas), the risk mitigation and management techniques and the systems that are in place to control and manage the installations in the safe way. The risks of the fuel gas facilities were evaluated both qualitatively and quantitatively by ERM with the results included in this report.

## **1.3 APPROACH**

The above purpose is assessed in this report by the following approach:

1. Presenting information on the management plan with potential of causing major accidents;
2. Describing the major accident prevention policy, and the associated safety management system to implement the policy, in particular the following:
  - (a) Safety management system organisation;
  - (b) Safety goals and standards;

- (c) The system for hazards identification;
  - (d) Operational control;
  - (e) Safety trainings to employees on-site;
  - (f) Emergency planning;
  - (g) Performance monitoring, audit and review
3. Demonstrating the major hazards have been identified, and measures have been provided to control or limit the consequences of hazards;
  4. Demonstrating that emergency response measures have been planned to limit the consequences in case of a major accident hazards occurs.

This Risk and Disaster Management Plan is based on the studies, information and procedures which have been done throughout the development of the project and are presented in the following parts of this report.

During this Design Stage, some documents and studies are not available. This document will need to update in next stage in order to take into account the progress of the project.

#### **1.4 STUDY BASIS**

Study basis of this report has been listed as follows,

The following information forms the basis for this Risk and Disaster Management Plan:

- Project Emergency Preparedness & Response Plan for Proposed Development of the Myingyan Gas-fired Combined Cycle Power Project, Revision 0 [1]
- Project HSE Manual, Hazard / Aspect Identification, Risk / Impact Assessment and Risk Controls, P2-01, Revision 6[2]
- Health, Safety, Security and Environment Plan (HSSE Plan) for Proposed Development of Myingyan Gas-fired Combined Cycle Power Project – Myanmar [3]
- Project HSE Plan Rev.01 [4]
- Environmental Resources Management, Myingyan CCGT ESIA Chapter 2, Process Description and Alternatives [9]





**ABBREVIATIONS**

ALARP	As Low As Reasonably Practicable
BOT	Build Operate and Transfer
BU	Business Unit
CCGT	Combined Cycle Gas Turbine
COSHH	Control of Substances Hazardous to Health
ERM	Environmental Resources Management
ERP	Emergency Response Plan
ERT	Emergency Response Team
ESIA	Environmental and Social Impact Assessment
GOM	Government of Myanmar
HAZID	Hazard Identification
HAZOP	Hazard and Operability
HR	Human Resources
HRSG	Heat Recovery System Generator
HSE	Health, Safety and Environment
HSSE	Health, safety, security and environment
ID	Identification
IMS	Integrated Management System
IPM	Integrated Procedure Manual
IPP	Independent Power Producer
LOTO	Lock Out / Tag Out
LTIR	Lost Time Incident Rate
MOEP	Ministry of Electric Power
MOGE	Myanma Oil and Gas Enterprise
MOI	Ministry of Industry
MW	Mega Watts
OGP	International Association of Oil & Gas Producer
OHSAS	Occupational Health & Safety Advisory Services
OSH	Occupational Safety and Health
OSHA	Occupational Safety and Health Administration
PM	Project Manager
PPE	Personal Protective Equipments
PTT	Pre-Task Talk
PTW	Permit-to-Work
QRA	Quantitative Risk Assessment
RA	Risk Assessment
RM	Risk Management
SDS	Safety Data Sheet
Sembcorp	Sembcorp Industries Limited
SOC	Safe Operations Committee
SWP	Safe Work Procedures
TRIR	Total Recordable Incident Rate
UK	United Kingdom
WMS	Work Method Statement
WSH	Workplace Safety and Health

### 3.1 PROJECT LOCATION AND SURROUNDING ENVIRONMENT

The Project site is located approximately 8km, south of Myingyan Township, Mandalay region in the Union Republic of Myanmar as shown in Figure 3.1.

The Power Plant will be located on a predominately green field site. The Project site is located adjacent to an existing steel mill (Myingyan Steel Mill No.4), owned by Ministry of Industry (MOI).

The Project site was acquired by the GOM and the registered land owner is MOI. The majority of this MOI-owned land is occupied by the existing steel mill infrastructure which was commissioned in 2007. The northern part was allocated for the Power Plant as shown in Figure 1.1. The Project site was cultivated farmland prior to acquisition of the land by the GOM and is currently dominated by sparse shrubby vegetation.

The following 5 villages are located in close proximity (3km radius from the Project site boundary), as shown in Figure 1.1:

- Sa Khar village;
- Hnan Ywa village;
- Hpet Taw village;
- Nyaung Kan village; and
- Gyoke Pin village.

In addition, there are 2 villages located in close proximity to the proposed water intake pumping station, which are Thien Ywa and Tha Pyay Thar village.

The Ayeyarwady River is located approximately 14km west of the Project site boundary. There is an existing gas pipeline (Shwe Gas Supply Pipeline), approximately 18km in length which runs from the Taung Thar offtake point to an existing MOGE gas receiving station within the Project site boundary. The location of the Ayeyarwady River and Shwe Gas Supply Pipeline is shown in Figure 1.1. To the north, south and west of the Project site boundary is the agricultural area, to the east is an existing dirt road.

#### 3.1.1 Existing Steel Mill Facilities

The existing Steel Mill produces approximately 200,000 tonnes per year of billets and slabs from recycled material such as scrapped metals and cars. It is currently undergoing expansion (Steel Mill Phase 2) to increase capacity with

upgraded sub-station (to be connected to both the steel mill and the Power Plant), melt shop, direct reducing plant and rolling mill.

### **3.1.2 *Aggreko Temporary Gas-Fired Power Plant***

In addition, there is an existing 95MW temporary gas-fired power plant located within the Project site boundary (see Figure 1.1) operated by Aggreko. The temporary gas-fired power plant began operation in April 2015 and comprises 92 gas engines rated at 1.3MW each (119MW total). The generated power is supplied to Myingyan town substation via the existing 132kV overhead transmission line. The temporary gas-fired power plant will be decommissioned once the CCGT Power Plant is in operation.

Figure 3.1 Location of the Project Site within Myanmar [9]

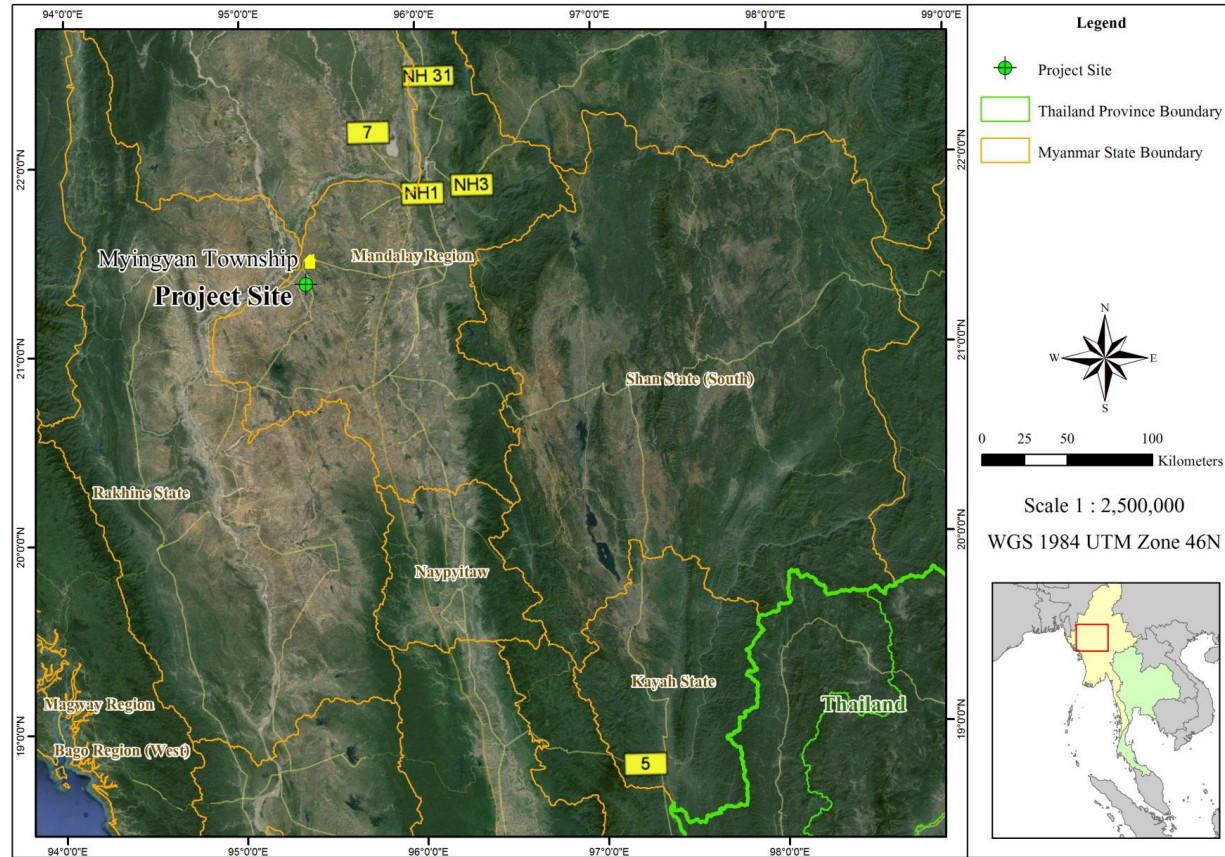

## 3.2 *PROJECT FACILITIES AND ASSOCIATED FACILITIES*

### 3.2.1 *Project Facilities*

The Project components are presented below and include Project Facilities (shown in *Figure 3.2*) and Associated Facilities. A total area of approximately 16 hectares (ha) is allocated for the Project facilities with the following facilities:

- **225MW Combined Cycle Gas Turbine Power Plant** (approx. 9 ha) comprising of the following main components:
  - 2 sets of Gas Turbine (GT) units;
  - 2 sets of Heat Recovery System Generator (HRSG);
  - 1 steam turbine generating unit with associated auxiliary equipment;
  - Switchyard area;
  - Cooling Water System;
  - Demineralised Water System; and
  - Wastewater Treatment Facility.
- **Gas Supply Pipeline** (approx. 0.2 ha) connecting the new MOGE gas receiving station to the Power Plant (approximately 1km in length). MEPE/MOGE will build the new MOGE gas receiving station and the Sponsor will build new gas supply pipeline from delivery point at the outlet of the MOGE gas skid to the Power Plant.
- **230kV Overhead Transmission Line** (approx. 5 ha) connecting the Power Plant to the upgraded Myingyan Steel Mill sub-station located within the steel mill complex (approximately 2.5km in length).
- **Water Supply Pipeline and Wastewater Discharge Pipeline** (approx. 2 ha) connecting the Power Plant to the water intake point and new Pumping Station at the Ayeyarwady River. The water supply pipeline will be approximately 14km in length. The wastewater discharge pipeline will connect the Power Plant to the existing irrigation canal (approximately 3km in length). The wastewater pipeline will be run in parallel with the water supply pipeline. Both pipelines will share the 2m easement.

### 3.2.2

#### *Associated Facilities*

The new MOGE gas receiving station (see *Figure 3.4*) to be installed by MEPE/MOEP for connection of the gas supply pipeline to the Power Plant is regarded as an associated facility.

In addition, the transmission connection beyond the upgraded Myingyan Steel Mill sub-station will be GOM's responsibility and therefore is classified as associated facility. The connection beyond the Myingyan Steel Mill sub-station transmission line is not known at this stage.

The Project components are described in the following sections.

### 3.2.3

#### *225 MW CCGT Power Plant*

The Power Plant is designed to operate continuously, either in simple cycle mode or in combined cycle mode. During simple cycle operation, the flue gas from the gas turbine will exit via the bypass stack to the atmosphere. During normal combined cycle operation, the heat of exhaust gas will be admitted to the HRSG where superheated steam will be produced which will drive the steam turbine to generate electrical power. The exhaust gas from the HRSG will be released from the main stack of the HRSG to the atmosphere.

The HRSG is designed for 3 pressures with reheat steam generation (High Pressure (HP), Intermediate Pressure (IP), Reheat (RH) and Low Pressure (LP)) used to maximize energy transfer from the exhaust gas of the gas turbine. The HP steam generated by the HRSG will be fed to the HP steam turbine and the reheat and LP steam will be fed to the LP steam turbine.

The power output is approximately 143MW during simple cycle and 225MW during combined cycle operation. The Power Plant will use natural gas as the only fuel.

The indicative layout of the Power Plant is shown in *Figure 3.2*. In addition, the Process Flow Diagram of the Power Plant is shown in *Figure 3.3*.

#### *Gas Turbine*

The GE 6F.03 heavy duty, multi-shaft gas turbine is selected for this Project. The configuration of this selected gas turbine is a multi-shaft, bolted rotor with the generator connected to the gas turbine through a speed reduction gear at the compressor or "cold" end. This feature provides for an axial exhaust to optimize the plant arrangement for combined cycle application.

The Power Plant will be operated based on grid dispatch instructions. The Power Plant will be declared available for full load in normal case. If one gas turbine is offline the other gas turbine in full load and steam turbine (50%) will be declared available. The Power Plant is capable for house load operation. In case of any trip, the Power Plant could be started within 2 hours any one of the gas turbines.

Two gas turbine units will be installed for the Project. The gas turbines will be installed within an acoustic, ventilated enclosure with fire detection and protection systems. The gas turbines will have all associated ancillary equipment and systems required for the safe, efficient and reliable operation of the unit under simple and combined cycle operation.

The gas turbine generator (GTG) specification for each unit is shown in *Table 3.1*.

**Table 3.1** *Gas Turbine Generator Specification*

<b>Feature</b>	<b>Specifications</b>
Model/Type	GE 6F.03
Fuel system	Gas only
Starting Means	Static Frequency Converter
Air filtration	Static type
Compressor/Turbine Cleaning	On and Off-line Compressor Water Wash
Exhaust System	Axial
Emissions Control	Gas - Dry Low NOx
Fire Detection	Heat Detectors
Gas Leak Detection	Gas detectors
Fire Protection	High pressure CO2 System
Off-Base Acoustic Enclosure	Turbine and Load Gear Compartments
On-Base Acoustic Enclosure	Lube oil and Gas module Compartments

Source: Sembcorp, 2015

The GTG's will be installed outdoors as shown in *Figure 3.2*. The GTG's will be capable of operation with their exhaust gases passing into the associated heat recovery steam generator, or as simple open cycle turbine generators, exhausting directly to atmosphere via an exhaust gas damper and the bypass stacks associated with each gas turbine (30m in height), located on the exhaust ducting upstream of the heat recovery boiler.

All cooling requirements for the turbine shall be met using heat exchangers, fed from the Closed Circuit Water (CCW) system.

Control of emissions of NOx will be achieved by Dry Low NOx (DLN) burners.

Audible and visual alarms will be located in the supervised areas in the Local Packaged Electrical and Electronic Control Compartment (PEECC). In addition, a Fire Detection System (FDS) will be installed at each gas turbine.

#### *Heat Recovery Steam Generator (HRSG)*

As one of the main units in a CCGT power plant, the two HRSG's (boilers) will be a natural circulation horizontal type HRSG with a three pressure with reheat system and an integral deaerator with no duct burners. The HRSG's will be combined with the gas turbines. The HRSG's are designed for exhaust gas conditions of the gas turbines fuelled with natural gas.

Steam generated by the HRSG's will enter the steam turbine. The High Pressure (HP), Reheat (RH) and Intermediate Pressure (IP) steam from the

HRSG's is sent to the steam turbine. Exhaust steam from the steam turbine will then enter into the condenser. The exhaust gas leaving the HRSG's will be routed to the HRSG stacks (40m in height).

The HRSGs will be sized to operate over the full range of ambient temperatures specified. The HRSGs consists of an economizer, evaporator, and super-heater tube bank section(s) with finned tubing, as appropriate, to maximize heat transfer. No supplemental firing facilities will be installed.

All pressure parts will be designed, manufactured and will be tested in accordance with "ASME Boiler and Pressure Vessel Code, Section 1, Power Boilers" or equivalent standards.

The HRSG specification is provided in *Table 3.2*.

**Table 3.2** *HRSG Specification (at design condition)*

<b>Feature</b>	<b>Specifications</b>
HP steam rating	85.0 t/h
HP steam pressure	14.4 MPa(a)
HP steam temperature	568 °C
IP steam rating	17.0 t/h
IP steam pressure	2.27 MPa(a)
IP steam temperature	300°C
LP steam rating	10.4t/h
LP steam pressure	0.4 MPa(a)
LP steam temperature	290°C
Feature	Specifications

Source: Sembcorp, 2015

### *Steam Turbine*

The steam turbine is a separate High Pressure (HP) and Low Pressure (LP) cylinder structure. The selected steam turbines are:

- HP: multistage/bleeding/backpressure type; and
- LP: multistage/bleeding/condensing type.

Each rotor is composed with groups (drums) of reaction stages. Both turbines are equipped with 2 (two) inlet flanges positioned in the head. The live steam flows through the emergency stop valves and the mass flow is regulated by control valves, which throttle all the steam flow; such valves are directly bolted to, and installed inside, the inlet section of turbine external casing for HP turbine, or installed separately on steam piping for LP turbine.

HP steam turbine has a downward radial exhaust flange, and LP steam turbine has an axial exhaust discharge flange. The steam turbine exhaust and condenser configuration will be in accordance to manufacturer's standard design.

The Steam Turbine Generator (STG) will be of proven design and complete with all auxiliary oil and steam systems. The STG will be installed indoors for

environmental protection (e.g., dust and rains) and to provide acoustic attenuation. The STG building will include an overhead travelling crane suitable for lifting the maximum heavy load for normal maintenance activities and suitable indoor laydown areas for plant maintenance. The STG specifications are outlined in *Table 3.3*.

**Table 3.3 Steam Turbine Generator Specifications**

<b>Feature</b>	<b>Specifications</b>
Rated out power	90 MW (to be determined )
Rated power factor	0.8 (lagging)
Rated rotation	3000 r/min
Rated frequency	50 Hz
Phase number	3
Cooling mode	TEWAC (Totally Enclosed Water-To-Air Cooled)
Insulation class	Class F (temperature rise as per Class B)
Exciting mode	Static Excitation System

Source: Sembcorp, 2015

### 3.2.4 Gas Supply Pipeline

Currently, the existing Steel Mill facility offtakes the gas from the Shwe gas pipeline, which is a Government-built gas supply pipeline. The gas supply pipeline from Taung Thar offtake point (on Shwe gas supply pipeline) is approximately 18km in length and connects to an existing MOGE gas receiving station located to the northwest of the steel mill built by the Government. This existing MOGE gas receiving station has been used to receive and supply gas to the steel mill and the existing onsite Aggreko temporary gas-fired power plant.

MOGE will install a new gas receiving station adjacent to the existing MOGE gas receiving station to supply gas to the Power Plant. The Project will build a new gas supply pipeline approximately 1km in length from the outlet of the new MOGE gas receiving station to the Power Plant (see *Figure 3.4*).

Design of the gas pipeline will be as per ANSI B 31.8: Gas Transmission and Distribution Systems. The class rating will be as per the final discharge pressure from MOGE new gas receiving station and will be either ANSI Class 300 or Class 600. Welding of pipeline will be as per API Standard 1104. The gas supply pipeline will be buried and have a minimum cover of 1.0m on top of it. Cathodic protection will be in place for the buried section of the pipeline and the design will be based on soil resistivity.

A natural gas supply and treatment system will be installed at the Power Plant to meet the required gas quality and pressure specified by the gas turbine manufacturer. The natural gas system will include backup metering equipment and all necessary, gas filter-separators, isolation and control valves, safety valves, and other equipment. The gas analysis is provided in Table 2.4.

**Table 3.4** *Shwe Gas (Natural Gas) Composition*

<b>Component</b>	<b>Mole Percent</b>	<b>BTU Gross</b>	<b>Relative Density</b>
C6 + 47/35/17	0.0199	1.05	0.0007
Propane	0.0297	0.75	0.0005
i-Butane	0.0109	0.36	0.0002
n-Butane	32.2 ppm	0.11	0.0001
i-Pentane	49.7 ppm	0.20	0.0001
n-Pentane	0.0000	0.00	0.0000
Nitrogen	0.2218	0.00	0.0021
Methane	99.5529	1007.81	0.5514
Carbon Dioxide	0.0491	0.00	0.0007
Ethane	0.1073	0.00	0.0011
TOTAL	100.0000	1012.18	0.5570

### **3.2.5** *230kV Overhead Transmission Line*

The proposed 230kV overhead transmission line alignment is approximately 2.5km in length and will be located between the generator transformer at the Power Plant and the upgraded Myingyan Steel Mill sub-station located within the steel mill complex. The proposed alignment is to the east of the Project boundary shown in *Figure 3.5*.

Connection beyond the upgraded Myingyan Steel Mill sub-station is GOM's responsibility. The connection beyond the upgraded Myingyan Steel Mill is not known at this stage.

### **3.2.6** *Water Supply Pipeline and Waste water Discharge Pipeline*

The proposed water supply pipeline alignment is approximately 14km in length and will run from the Power Plant along an existing irrigation channel connecting to the Ayeyarwady River for water intake (see *Figure 3.6*). The proposed alignment is surrounded by predominantly agricultural/modified land and some shrubs. The proposed alignment is expected to go underneath several existing dirt paths and roads including the Nyaung U-Myingyan highway.

Land required for the water supply pipeline would be minimal as the majority of the water supply pipeline will be located along the existing irrigation channel.

There is an existing floating pump house for supply of water for irrigation, located at the irrigation channel intake on the Ayeyarwady River. Due to capacity requirements, this pump house is considered to be unsuitable insufficient for supplying water to the proposed Project and a new pump house will be constructed by the Sponsor. The pumps will be located on a floating pontoon with shed.

In terms of social features, the proposed alignment avoids crossing existing villages. Near the outlets on the Ayeyarwady River the water supply pipeline is expected to have several communities of the Tha Pyay Thar village on either

side of the proposed alignment and pass through the south of Hla Naung Taung village (see Figure 2.2).

The proposed wastewater discharge alignment is approximately 3km in length and will run alongside the water supply pipeline from the Power Plant to the existing wastewater channel (see Figure 3.6).

### 3.3 *PROJECT LIFE CYCLE*

#### 3.3.1 *Construction Phase*

Construction is expected to start in the first quarter of 2016 and be complete in the region of 22.5 months with commercial operation targeted at the first quarter of 2018.

Construction activities of the Project will include: mobilisation, site clearance, onshore construction of all Project components, Nyaung Hla jetty reinforcement and commissioning. Heavy equipment such as bulldozers, excavators, dump trucks, compactors, etc. will be used at the Project site.

The normal construction hours are anticipated to be 10 hours per day, 6 days per week.

#### 3.3.2 *Operational Phase*

The start of operation is anticipated for the first quarter of 2018. Simple cycle operation will occur during the first five months of operation before the combined cycle plant is complete.

The anticipated workforce during operation is shown in *Table 3.5*

**Table 3.5** *Anticipated Workforce during Operation*

Description	Staff Number
Permanent Staff	48
Security (external)	12
Contract staff: Cleaners, Gardeners and helpers	10
Contract staff: Technical hands	10
Maintenance (once every 3 years)	90 for 30 days

The operational working hours / shift structures will be as follows:

- 12 hours per shift with 4 shift teams;
- 2 days shift 1 day off, 2 nights shift 3 days off (including sleeping off);
- 1 shift charge, 1 unit controller and 2 field technicians per shift; and
- 18 staffs will be in the shift roster

### *Emergency Diesel Generators*

The Power Plant will have one emergency diesel generator with a capacity 800kWh that will be used during plant safe shutdown. The diesel will be transported appropriately to the Project site using Material Safety Data Sheets (MSDS) from diesel suppliers in Myanmar. The diesel generator will be the stationary emergency type and will consist of control gear, lubricating oil system, fuel day tank, cooling system, direct current (DC) starting power and synchronizing equipment, and electrical protection system equipment. Following an emergency shutdown at the power plant, the diesel generators will provide electrical power to maintain the turbine generator unit and its auxiliaries in safe conditions. The diesel generator will not exceed operation for more than 2 hours which is considered to be sufficient.

### *Fire Protection System*

The Power Plants fire protection system will provide personnel safety and plant protection through prompt detection, alarm and suppression of a fire. The system will be designed for any single design basis fire and will be in accordance with all local applicable codes and standards. The primary source of water for the system shall be from the plant's water system.

### *Power Plant Maintenance*

During operation, maintenance will be associated with the following:

- Breakdown Maintenance;
- Planned Preventive Maintenance;
- Routine Maintenance; and
- Scheduled Preventive Maintenance.

### **3.3.3**

#### ***Decommissioning Phase***

The design life of the power plant is estimated to be 25 years. If the Power Purchase Agreement, Land Lease Agreement, Gas Supply Agreement and the other relevant agreements are not extended or renewed and an alternative economical fuel is available, the power plant may be retrofitted to support alternative power generation. This option would be possible, provided the required retrofits and new emission rates meet the applicable standards and guidelines.

If retrofitting is not feasible and the operational life of the Power Plant expires, the Power Plant will be decommissioned according to the requirements of the authorities at that time according to best industry practices.

Figure 3.2 Project Facilities [9]



Figure 3.3 Process Flow Diagram of the CCGT Power Plant [9]

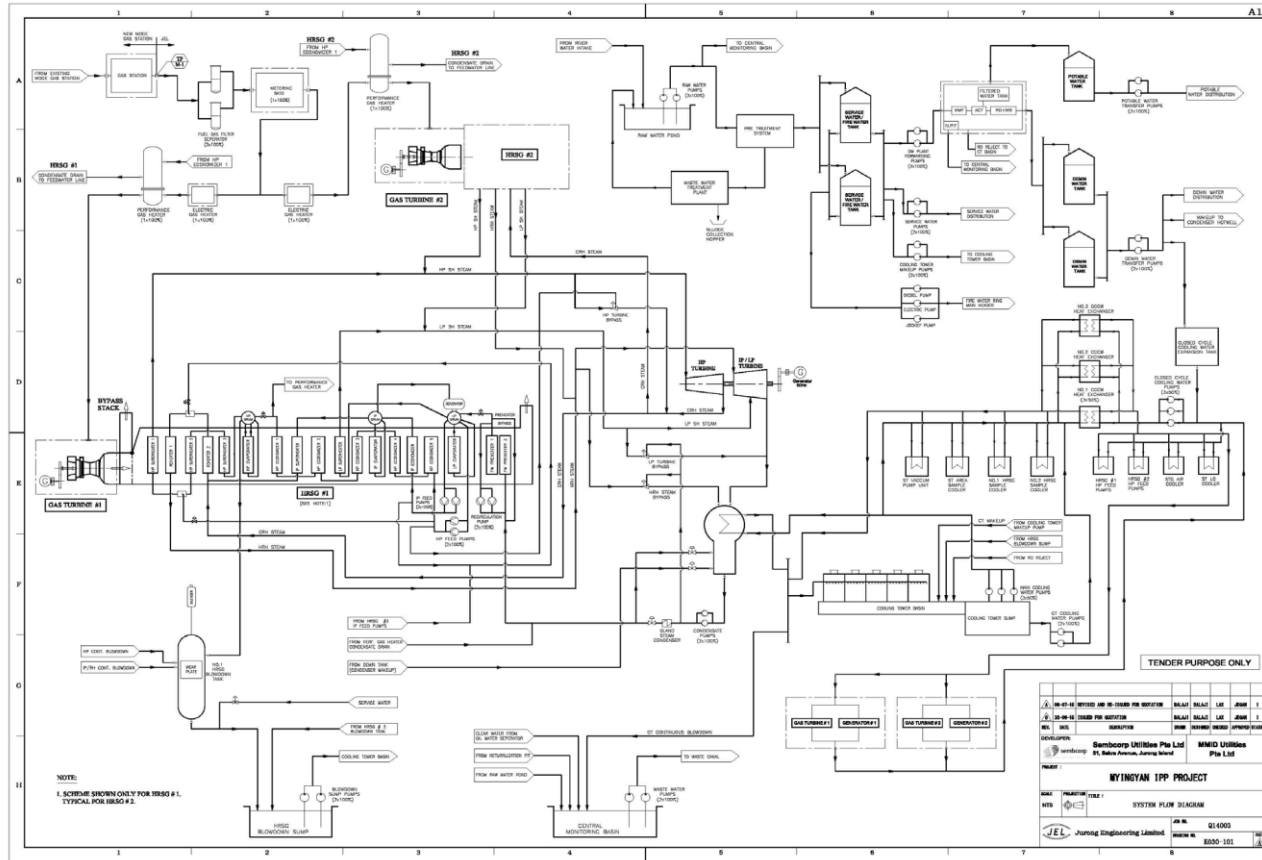

Figure 3.4 Proposed Alignment of Gas Supply Pipeline from New MOGE Gas Receiving Station to the Power Plant [9]

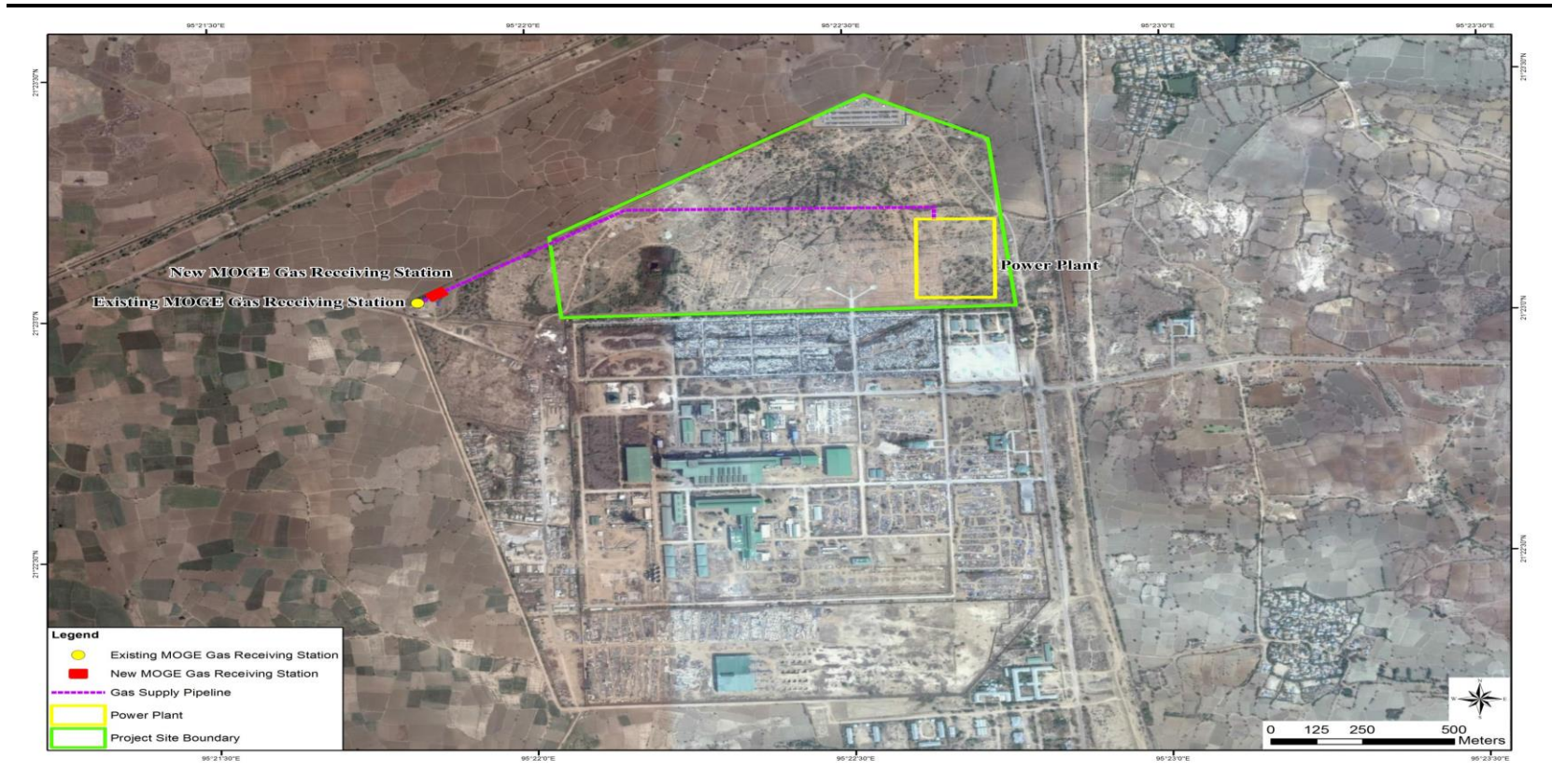

Figure 3.5 Proposed Alignment 230kV Overhead Transmission Line Route from Power Plant to Upgraded Myingyan Steel Mill sub-station [9]

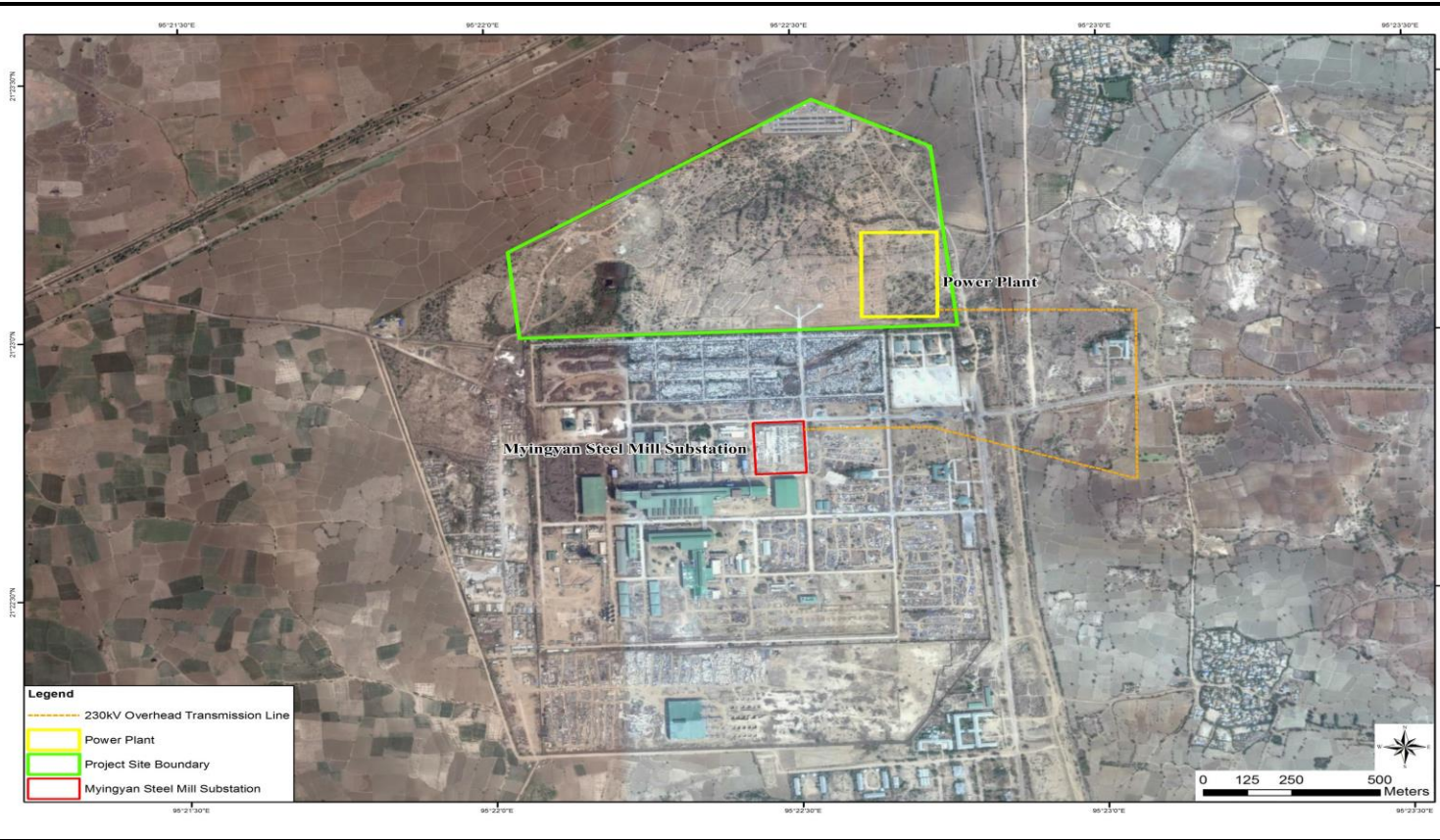

Figure 3.6 Proposed Alignment of Water Supply Pipeline from the Power Plant to the Ayeyarwady River Water Intake Point and Wastewater Discharge Pipeline [9]



### 3.4 DANGEROUS SUBSTANCES IN USE

The major dangerous substances (DS) on site had been identified to be:

- Shwe Gas (Natural Gas);
- Diesel Oil
- Various package dangerous substances (in Chemical Storage House, such as acids, alkalis, compressed gases, solvents, etc.)

The properties of natural gas and diesel oil are briefly described in *Table 3.6*.

**Table 3.6** *Properties of Natural Gas and Diesel Oil*

	Natural Gas	Diesel Oil
Physical State	Gas	Liquid
Molecular weight	19.5	Varies
Density (kg/m <sup>3</sup> )	0.7 - 0.9	820 - 950
Boiling Point	-161.	288 - 338
Flash Point	N.A.	>66
Flammable Limits (%)	5 - 15	1.6 - 6
Auto-ignition Temperature (°C)	580	210

#### 3.4.1 Natural Gas

##### *Hazards*

Methane, the primary component of NG, is colourless, odourless, tasteless, and is an asphyxiant (meaning that if a significant quantity NG is present, there will be insufficient oxygen to breathe). NG is not easy to detect because it is odourless.

At a 5% concentration of gas in air, NG is at the Lower Flammability Limit (LFL). Below this gas/air ratio, the gas is too dilute for ignition, and fire or explosion cannot occur. Also, at a 15% concentration NG is at its Upper Flammability Limit (UFL). Above this gas/air ratio, the mixture is too rich to ignite.

#### 3.4.2 Diesel Oil

Diesel Oil is stored onsite to provide an alternative fuel for emergency diesel engine generator, emergency diesel generator in the event of non-availability of NG. Diesel has a relatively high flash point (>52°C), which is above ambient temperature, and a high boiling point. Thus, evaporation from a liquid pool is expected to be minimal. The major hazard arising from diesel ignition is therefore considered to be pool fire. As the diesel oil is only used during emergency condition and the amount stored in the storage tank is not high, 4,000L/month, the likelihood and hazardous consequence is considered minimal.

### 3.4.3 Other Dangerous Goods On-site

In addition to natural gas and diesel oil, several dangerous substances are stored and handled at Sembcorp CCGT Power Plant. These are summarised in *Table 3.7*.

**Table 3.7 Hazardous Materials during Operation**

<b>Hazardous Material</b>	<b>Hazardous Material</b>	<b>Hazardous Material</b>	<b>Hazardous Material</b>
Oxygen Scavenger	Chemical Dosing System	Chemical Storage House	1m <sup>3</sup>
Phosphates	Chemical Dosing System	Chemical Storage House	1m <sup>3</sup>
Fouling Agent	Chemical Dosing System	Chemical Storage House	1m <sup>3</sup>
Anti-corrosion	Chemical Dosing System	Chemical Storage House	1m <sup>3</sup>
Biocides	Chemical Dosing System	Chemical Storage House	1m <sup>3</sup>
Hydrochloric Acid	Chemical Dosing System	Chemical Storage House	3m <sup>3</sup>
Sodium Hydroxide	Chemical Dosing System	Chemical Storage House	3m <sup>3</sup>
Sodium Hydroxide	Water Treatment System and Demineralised Water System	Chemical Storage House	10m <sup>3</sup>
Hydrogen Chloride	Water Treatment System and Demineralised Water System	Chemical Storage House	10m <sup>3</sup>

### 3.5 ORGANISATION AND MANAGEMENT STRUCTURE OF SEMBCORP GAS-FIRED CCGT POWER PLANT

At the moment of construction stage, Sembcorp gas-fired CCGT power plant is managed by the Sembcorp Design and Construction Pte (SDC) management team and is aided by the SDC support team and local SDC teams as shown in *Figure 3.7*. The organisation and management structure at the operation phase has not yet been formed as the project is in an early development stage.

Figure 3.7 Project Organisation Chart

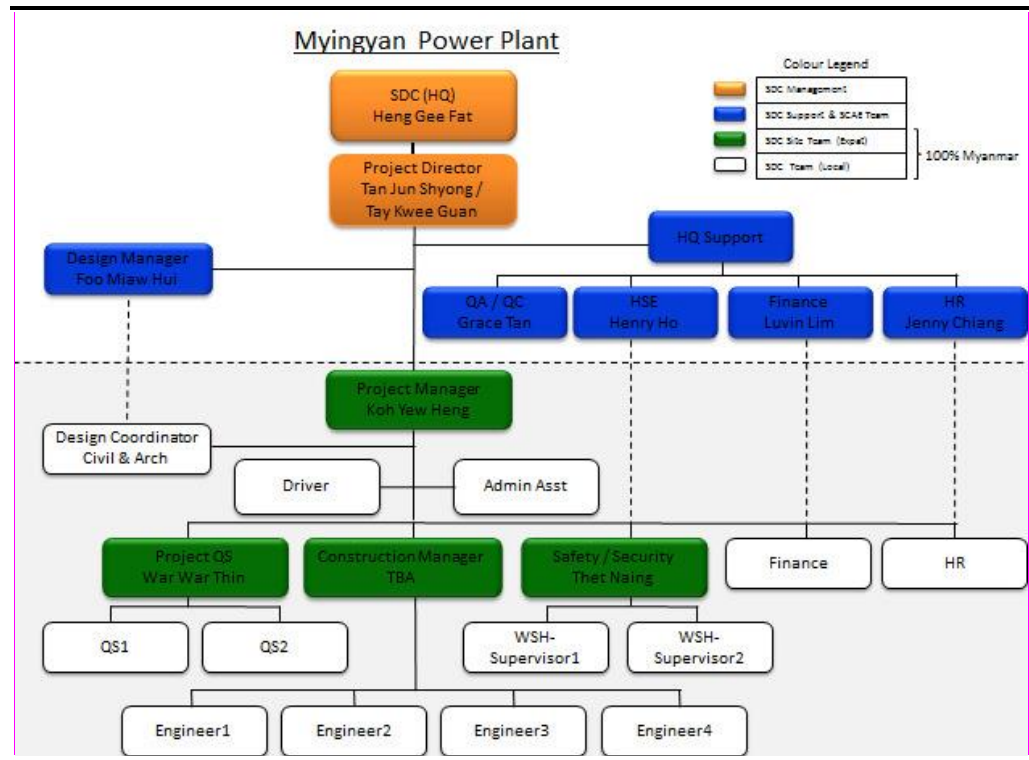

This section will identify the potential Major Accident Hazards (MAH) scenario that could happen in the CCGT Power Plant. The relevant hazards and current mitigation measures employed will be identified in general terms. Potential techniques to be used to further identify the specific accident scenarios and recommendations to mitigations measures will be provided.

#### 4.1 ON-SITE MAJOR ACCIDENT HAZARDS

##### 4.1.1 Leakage of Fuel Gas

###### *Possible Incidents Involving Fuel Gas Leakages*

The gas facilities may suffer a spontaneous failure or damage to gas pipework or equipment that results in a loss of containment of the fuel gas. Whenever there is a loss of containment of fuel gas, there is a danger of a fire or an explosion occurring if a source of ignition is present. To a certain extent, leaking gas will disperse naturally or can be dispersed by mechanical ventilation, but even a moderate leakage rate may generate a flammable gas cloud that can ignite. The downwind distance that flammable gas might reach depends on the volume of FG leaked, the rate of the leak, the prevailing weather conditions and source of ignition. Depending on these factors, the ignition of the gas may result in:

- A flash fire (a short duration fire of an isolated gas cloud);
- A jet fire (a fire that burns back to its source and continues burning); or
- An explosion.

Flash fires will injure personnel and can cause extensive damage, if within a confined or congested space. The effect of a flash fire on a person caught within it is often fatal. Flash fires may occur in unconfined clouds of FG. The combustion normally occurs only within portions of the cloud where the gas/air mixture is within the flammability limits, rather than the entire cloud. Where there is a continuing source of gas leakage the fire will normally flash back to the source of the leakage and continue to burn. Where this source of leakage is significant and gas is escaping at high velocity, a jet fire will result. This can burn intensely and, if it impinges on adjacent pipework or equipment, has the potential to cause considerable damage in a relatively short time.

Jet fires can cause severe damage, but generally only within the local area of the flame. There is a danger of secondary incidents arising as a result of damage to nearby equipment.

An explosion can result under certain conditions, but a specific gas and air mixture must exist and it is generally thought that a degree of confinement and congestion is necessary for a significant explosion to occur. Explosions are therefore less likely than fires.

#### *Potential Areas or Processes of Gas Leakages*

Gas incidents can arise in the following areas:

- Gas Supply Pipeline, Gas Treatment Plant and MOGE Gas Receiving Station

This equipment is constructed in areas entirely within Sembcorp's control, and so third party damage is unlikely. Also, the equipment is remote from other parts of the plant, and unlikely to be affected by other incidents onsite. The equipment is designed and built to the ASME Code, and maintenance has been scheduled, thus equipment failure should be infrequent. Part of the feasible modes of failure have been analysed in the QRA study for gas supply pipeline, as described in *section 4.4*.

The potential sources of leakage are joints on piping, valves and instruments. Spontaneous failure due to stress or fatigue in pipework is also possible. External corrosion is a possible cause of failure.

However, as the fuel gas facilities operate at relatively high pressures (about 30 barg onshore), a sizable leak can potentially occur. Any fire that results from this will be intense and will damage adjacent facilities, and so escalate the events to a more serious situation.

- Gas equipment at CCGT Power Plant during opening for maintenance

If equipment containing NG is opened, a flammable mixture of gas and air may be formed, posing a potential fire and explosion risk. The risk is particularly great in areas where ignition sources may be present.

Conversely, NG equipment that has been opened and then closed up for returning to service will be contaminated with air. Thus, an explosive mixture may form inside when NG is reintroduced. These risks can be mitigated by purging.

- Turbine units

This equipment is designed and constructed to the same standards to ASME code. Again, leakage from joints is the most likely scenario. However, secondary failure due to some other incident within the turbine halls is possible.

Any significant leak will require immediate shutdown of the unit to minimize the risk of fire and explosion.

- Inventory of NG in the Processing Equipment

In the event of a leak within CCGT, once the processing equipment has been isolated (e.g. by operation of the ESD valves at the MOGE gas receiving station), the total inventory remains in the system may still lead to flammable effects as described above.

#### *Recommendations*

Based on the identified potential MAH, additional safeguards are recommended to enhance the mitigation means against MAH:

- Recommendation 1: all pipes and equipment should be suitably coated against external corrosion. Also, lagging should be provided with removable panel to facilitate routine inspection of the condition of the pipework surface.
- Recommendation 2: Area around the gas supply pipeline and valve stations should be zone-classified and access-controlled to eliminate any source of ignition.
- Recommendation 3: Consider implementing a HEMP (Hazard and Effects Management Process) to identify and manage the major accidental hazards.

### **4.1.2**

#### *Explosions*

Incorrect operation or incidents during work on FG equipment poses a significant risk. Several possible scenarios are as follows:

- Internal explosion in the flare stack due to ingress of air and subsequent ignition;
- Internal explosion in the gas turbine combustor due to incorrect start-up procedures;
- Internal explosion in other parts of the plant due to gas ingress and subsequent ignition; or
- Vapour Cloud Explosion in congested areas from gas facilities.

#### *Recommendations*

- Recommendation 4: a Quantitative Risk Assessment (QRA) needs to be performed during EPC stage for the Power Plant in order to evaluate the risk due to the explosion events to the On-site, Off-site population as well as the adjacent facilities. The Emergency Response Plan needs to be updated in order to take into account these explosion events.
- Recommendation 5: a HAZID for commissioning/ start-up can be performed during EPC stage in order to identify all potential risk due to these operations.

*Scenarios involving major accident hazards other than FG*

Significant accidents may occur onsite as a result of fires involving Dangerous substances (DS), or due to failure of turbine blades. However, there is relatively little potential for such incidents to escalate into incidents involving FG. To confirm this, in terms of the scope of this Risk and Disaster Management Plan, consideration must be given as to whether:

- A DS fire incident can escalate into an FG incident by causing damage to FG equipment;
- A turbine blade can shear off and cause physical damage to nearby FG equipment; or
- A FG incident can escalate by causing a DS fire.

*Escalation of a DS fire into a FG incident*

The DSs onsite are stored away from the FG facilities such that there is little scope for a DS fire to cause damage to FG equipment. Thus, escalation is not a reasonably feasible scenario. If escalation could occur, the scenario would be similar in outcome to the spontaneous failure modes of FG facilities. Thus, mitigation measures developed for spontaneous failures may also apply to escalation scenarios.

*Recommendations*

- Recommendation 6: Layout study should be conducted to assess adequacy of separation distances from major hazard installations to sensitive equipments, buildings and emergency assembly area locations.

*Turbine damage causing an FG incident*

It is feasible that a turbine blade may shear off, damaging FG equipment and causing a gas leak which may be considered as a generic failure of FG equipment. The turbines at the CCGT are subject to regular maintenance and inspection. Therefore, the likelihood of catastrophic failure of the turbine blades is expected to be low.

*Escalation of FG incidents by causing a DS fire*

The most plausible scenario escalation of FG incidents by causing a DS fire is impingement of a FG jet flame from Gas Treatment Plant.

If a DS fire did break out, the nature and inventory of DSs onsite is such that no additional offsite impact is plausible – apart from a smoke plume.

Physical separation of FG and DS equipment means that escalation is less likely even for a jet fire incident.

There are hazards that are outside the control of Sembcorp Management, but could still pose a risk to the installation. These hazards are called “external” because they are independent from the onsite operation and can cause major accidents onsite. A number of plausible causes of hazards are listed as below:

- Third party damage to gas supply pipeline;
- Aircraft crash;
- Severe weather conditions;
- Subsidence;
- Earthquake;
- Flooding; and
- Vehicle impact

The cause and general consequences are described in the following sub-sections.

#### **4.2.1 *Third Party Damage to Gas Supply Pipeline***

The Gas Supply Pipeline is possibly of damaged by a third party beyond the CCGT site boundary, which could result in a gas leak on the pipeline. A quantitative analysis of this risk has been carried out [5], and reviewed to confirm its validity for this Risk and Disaster Management Plan; see *section 4.4*. Cathodic protection against external corrosion will in place for the buried section of the pipeline designed based on soil resistivity [5].

#### **4.2.2 *Aircraft Crash***

Most aircraft crashes occur during take-off or landing, within a limited 3km zone at either end of airport runways. CCGT power plant is outside this zone, and thus risk of aircraft crash on CCGT power plant is considered negligible.

#### **4.2.3 *Severe Weather Conditions***

Lightning strike is believed to have contributed to major incidents at oil and gas facilities in a number of locations worldwide. Sembcorp is not especially prone to lightning, and relevant equipment should be protected with lightning conductors and the risk arising from lightning strike does not pose an exceptional hazard at CCGT Power Plant. However, if FG equipment is damaged during a storm, and a gas leak occurs, this will be detected and handled in the same way as a gas leak from any other cause. This has been addressed on design of the Power Plant.

#### 4.2.4 *Subsidence*

Normal subsidence events will occur gradually over several days or even months in which appropriate mitigation measures can be taken to prevent the failures to damage pipework or vessels. Only sudden and severe subsidence could result in failure of pipework or vessels which can lead to the shutdown of gas facilities and isolation of the relevant equipment.

##### *Recommendations*

- Recommendation 7: Comprehensive soil investigation survey is recommended to investigate ground settlement / subsidence risk.

#### 4.2.5 *Severe Earthquake*

Myanmar is lying in a major seismic belt which is indeed earthquake-prone and is vulnerable to hazards from moderate to large magnitude earthquakes including tsunami hazards along its long coastal areas [6]. The hazardous scenarios ranges from minor gas leak to catastrophic failure of gas facilities. Damage to pipework could occur due to ground movement or vibration leading to guillotine failure of pipes. Loss of containment from a storage vessel could result due to:

- Vessel structural support failure;
- Building roof/structure collapse; and
- Vibration induced stress failure.

The intensity of earthquake required to damage storage vessel or pipework would be in excess of Modified Mercalli Intensity (MMI) VII [7].

##### *Recommendations*

- Recommendation 8: The design of the Power Plant should be such that the impacts due to severe earthquakes are minimized.

#### 4.2.6 *Flooding*

Flooding is likely to occur in Myingyan as it is situated 14km east to the Ayeyarwady River [8] and it may cause equipment failure resulting to gas leak if FG equipment is damaged. Flooding in Myingyan shall also be taken into account in the plant design stage.

#### 4.2.7 *Vehicle Impact*

The risk of a FG incident arising from a vehicle striking piping or equipment is possible which may lead to pipe leakage. Adequate control with crash barriers, restriction of access should be employed for authorized vehicles only, onsite speed limits and training are recommended to reduce this risk.

Selection of a method for a process hazard analysis depends on many factors such as the size of equipment, complexity of the process and existing knowledge on the process.

A hazard assessment study should comprise of the following elements:

- Identification of all hazardous scenarios associated with on-site transport (including piping), storage and handling of dangerous substances at the hazardous facility;
- Execution of a Quantitative Risk Assessment expressing population risks in both individual and societal terms;
- Comparison of individual and societal risks with the Criteria for Evaluating Hazard to Life in accordance with international guidelines/ standards.
- Identification and assessment of practicable and cost-effective risk mitigation measures

#### 4.3.1 *Hazard and Operability Analysis (HAZOP)*

HAZOP is a well-defined, systematic technique for hazard identification. It can be applied to processes for which design information is available. This information commonly includes a piping and instrument diagram (P&ID), which is examined in small sections, such as individual items of equipment or pipes between them. For each of equipment or process, the possible significant 'deviations' (such as 'less flow') from each design intention, feasible 'causes' for those deviations, and potential 'consequences' are determined. It can then be decided whether existing, designed safeguards are sufficient, or whether additional actions are necessary to reduce risk to an acceptable level.

#### 4.3.2 *Quantitative Risk Assessment (QRA)*

Quantitative Risk Assessment is a well-defined, detailed numerical analysis of risk. It requires calculations of two components of risk: the magnitude of the potential harm  $L$ , and the probability  $p$  that the harm will occur. Previous similar incidents or a model, which can be generated with modelling software, can be used to estimate the values of these two components. Results can be expressed in terms of the likelihood of harm to a single individual, in the form of a probability contour plot. In addition, the risk to an offsite population can be calculated, and expressed as a plot of number of fatalities vs. frequency of incident. Because of the complexity of QRA and the need to obtain failure rates of specific items of equipment, it is carried out when required by the Authority under normal circumstances.

As the project is still in the preliminary design stage, only the Quantitative Risk Assessment (QRA) on gas supply pipeline has been conducted. Hazard and Operability (HAZOP) studies and full Quantitative Risk Assessment (QRA) on the plant facilities are recommended to be conducted to identify major accident scenarios in the EPC stage when detailed design is available.

Key input data for gas supply pipeline QRA, such as process conditions, inventory and population has been reviewed and given in Appendix A. The conclusion state that the risk to offsite population is 'acceptable' for gas supply pipeline in terms of UKHSE Guidelines and guidelines from BS PD 8010 Part 3 "Code of practice for pipelines Part 3: Guide to the application of pipeline risk assessment to proposed developments in the vicinity of major accident hazard pipelines containing flammables".

A number of recommendations for improvement were made during the QRA study. These are listed in Appendix B.

## 5 MAJOR ACCIDENT PREVENT POLICY AND SAFETY MANAGEMENT SYSTEM

### 5.1 MAJOR ACCIDENT PREVENTION POLICY REVIEW

#### *Risk Assessments*

HSE Risk Register review shall be carried out by the RM/RA team comprising appropriate staff from relevant disciplines / departments once every 3 years or earlier as stipulated in this procedure, but not limited to:

- New or changes to activities, products, services and environment for all ongoing and new projects undertaken;
- New or revised legislations, regulations and other requirements applicable to the company;
- Results of the review shall be considered when formulation and completion of new HSE management programs;
- New equipment, material or chemical used;
- Results of management review;
- Corrective actions and preventive actions;
- Shut-down and start-up conditions;
- Inspections;
- Foreseeable emergency situations; and
- Findings from accidents, incidents and complaints or feedback (both internal and external) which is significant.

All job tasks require PTW shall accompanied with a RA.

The respective Head of Department (Manager) shall assign the competent functional Risk Management (RM) Team to conduct RA. Appointment letter shall be issued to competent personnel by Senior Management / Head of Department.

The team may include representatives from Operations, Maintenance, HSE, Project, HR / Admin, Materials and Services, Laboratory and other functions as appropriate.

Contractors / supplier representative shall be included in the RM team if they are involved in the work activity.

Workplace Safety and Health (WSH) professional or consultant may be engaged in assisting RM leader for conducting RA where RA experience and expertise is lacking.

Separate teams may be formed to evaluate particular groups of activities, products and services. The team may also call upon other individuals when needed.

The responsibilities of the team members are as follows:

Team Leader:

- Act as a focal point for co-coordinating RM including initiate review and update of P2-01-F1 HSE Risk Register at your respective BU / department.
- Prepare, review and update the HSE Risk Register(s) according to P2-01 Hazard / Aspect Identification, Risk / Impact Assessment and Risk Controls together with team members.
- Obtain Head of Department's endorsement & approval on the HSE Risk Register(s) and implementation of risk control measures.
- Provide regular updates to Head of Department on the effectiveness of the appropriate risk control measures after implementation.
- Assist Head of Department to ensure that the RA is prepared in accordance to Hazard / Aspect Identification, Risk / Impact Assessment and Risk Controls.
- Ensure his/her team members obtain the necessary prescribed competency.
- Update all members of any legal updates/changes affecting the RA.
- Provide update in monthly HSE committee meeting on the RA conducted and risk control measures implemented or in such other intervals as necessary.
- Assist to ensure that all employees under the concerned discipline are aware of the RA for the work activity they carry out.
- Maintain a list of updated HSE Risk Register(s) & its relevant records (including written description of safe work procedures) for at least three (3) years from the date of the assessment and produce to the regulatory personnel when requested.
- Assist to develop and implement safe work procedures for work which poses HSE risks to workers.

Team Members:

- Prepare, review and update the HSE Risk Register(s) according to procedure together with Team Leader(s).
- Assist Team Leader(s) in conducting & implementing RA and recommend appropriate risk control measures to reduce or eliminate the risks identified.
- Assist Head of Department in monitoring the effectiveness of risk control measures after their implementation.
- Assist to ensure that all employees under the concerned discipline are aware of RA for the work activity they carry out.
- Maintain a list of updated HSE Risk Register(s) & its relevant records (including written description of safe work procedures) for at least three (3) years from the date of the assessment and produce to the regulatory personnel when requested.
- Assist to develop and implement safe work procedures for work which poses HSE risks to workers.

*Vehicle Restrictions*

Only vehicles with proper approval and that are necessary for performance of the work shall be allowed on the work site. Personnel will comply with site policies on vehicle restriction and Site Traffic Plan. Vehicles shall only be parked in designated areas.

*Hazardous materials and dangerous goods on-site*

All hazardous materials and dangerous goods shall be kept, stored, used, handled or disposed of in such a manner so as not pose a risk to the health and safety of any person at work.

All hazardous materials and dangerous goods shall be placed under the control of a competent person who has adequate knowledge of the properties of the Hazardous Materials and Dangerous Goods and their dangers.

5.2 SAFETY MANAGEMENT SYSTEM

5.2.1 Organisation and Responsibilities of the Emergency Response Team (ERT)

Emergency Response Team (ERT)

According to the Project Emergency Preparedness and Response Plan, the Emergency Response Team (ERT) organisation chart is given below.

Figure 5.1 Emergency Response Team Organisation Chart

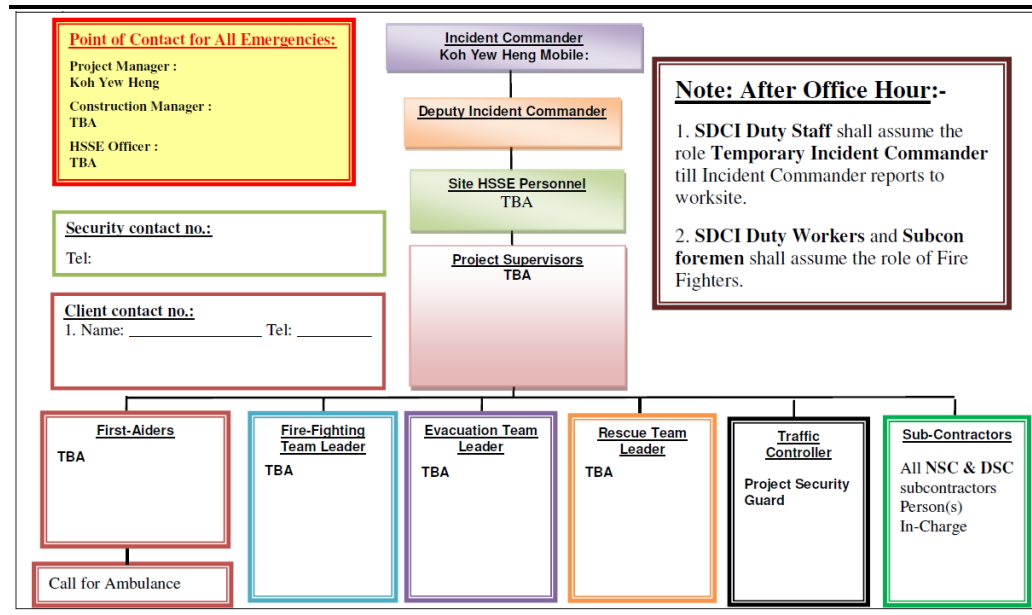

The Project Emergency Preparedness and Response Plan stating responsibilities and work tasks exclude or at least reduce risks during the operational phase of the CCGT Power Plant. It is the duty of all project participants.

Safety is a management and line responsibility throughout the entire organisation as shown in Figure 5.1. Each individual project participant is responsible for safety within his own area of responsibility and to report safety in the line organisation

5.2.2 Incident Commander

The responsibilities of the incident commander are:

1. Forming the Project Emergency Response Team (ERT).
2. Overall person in-charge in the event of an emergency situation.
3. Provision of adequate resources for the ERT (i.e. manpower, equipment, etc.).

4. In-charge of liaising with the Client's site representative (PCo) and project top management.
5. Assess the situation of the incident and activate the project ERT members for counter measures.
6. Direct all counter measures and emergency procedures to control and suppress the situation, decide on the evacuation of the construction site.

### **5.2.3 *Deputy Incident Commander***

The responsibilities of the deputy incident commander are:

1. Assist the Incident Commander on the coordination and execution of the project emergency response procedures.
2. To cover the duties of the Incident Commander when he is not at site.
3. Person in-charge of coordination and directing of the project ERT.
4. Collating and reporting the headcounts of the emergency evacuation to the Incident Commander.
5. Directing the search and rescue of missing personnel.

### **5.2.4 *Site HSSE Personnel (HSSE Officer / HSSE Coordinator)***

The responsibilities of the Site HSSE Personnel are:

1. To assist the Incident & Deputy Incident Commander on execution and directing of project emergency response procedures.
2. Assist in assembling and coordination with the project ERT.
3. Assist in coordinating work at the emergency evacuation assembly area.

### **5.2.5 *Project Management Supervisors***

The responsibilities of the Project Management Supervisors are:

1. Inform all personnel of the emergency situation.
2. Lock all office documents and shut down all electrical equipment if possible.
3. Evacuate from their respective work areas calmly upon activation of emergency evacuation.
4. Remove all sensitive documents with them during evacuation if possible.
5. Assist any personnel who require any help.
6. Assemble at the respective emergency assembly area.
7. Conduct headcount and report to the site HSSE personnel / Deputy Incident Commander.

### 5.2.6 *Qualified First-Aiders*

The responsibilities of the Qualified First-Aiders are:

1. Setting up of the first-aid treatment area at the project emergency evacuation assembly area.
2. Rendering first-aid to the injured.
3. Coordination, directing and reporting to the external professional medical personnel.
4. Reporting the status of injured personnel to the Incident Commander / Deputy Incident Commander.

### 5.2.7 *Fire-Fighting Team*

The responsibilities of the Fire-Fighting Team are:

1. Conducting fire-fighting in the event of a fire emergency.
2. Directing personnel to evacuate from the scene of fire.
3. Coordinating the rescue of personnel with the Rescue Team members from the scene of fire.
4. Remove any flammable materials.

### 5.2.8 *Evacuation Team*

The responsibilities of the Evacuation Team are:

1. Set up the project emergency evacuation assembly area upon activation.
2. Organise the evacuees according to their companies.
3. Liaise with the respective persons-in-charge from the different companies & work groups and collate the headcounts.
4. Reporting the headcounts to the Deputy to check the number of people present and missing and report the status to the Incident Commander.

### 5.2.9 *Rescue Team*

The responsibilities of the Rescue Team are:

1. Coordinating the evacuation & rescue of personnel.
2. Cooperating with the fire-fighting team on the rescue of personnel.
3. Cooperating with the respective persons-in-charge of the personnel on the rescue of missing personnel from their working areas.
4. Reporting to the Deputy Incident Commander on the status of their rescue.

### 5.2.10 *Project Security Guards*

The responsibilities of the Project Security Guards are:

1. Inform the Site HSSE Personnel on the workers and subcontractors manpower on site.
2. Control the site personnel and vehicle traffic movement.
3. Stop all personnel/ vehicles from entering the worksite in the event of an emergency.

### 5.2.11 *Sub-Contractors / Person(s) In-Charge*

The responsibilities of the Sub-Contractors / Person(s) In-Charge are:

1. Inform all their personnel of the emergency situation and carry out evacuation when instructed.
2. Ensure all personnel are evacuated from their work areas and assemble them at the emergency assembly area.
3. Ensure all machineries, equipment, etc. are shut down before leaving the work area.
4. Conduct headcount of their work personnel and report the headcount to the site HSSE personnel / deputy incident commander.
5. In the event of missing personnel, inform the rescue teams on the last know working area of the missing personnel.
6. Ensure their personnel assemble neatly at their respective positions and wait for further instructions from the site HSSE personnel / Incident or Deputy Incident Commander.

## 5.3 *PROJECT HSE PLAN*

### 5.3.1 *Objectives and Targets*

The project shall take a systematic approach to meet or exceed Sembcorp and Statutory requirements by setting the following objectives:

Promote and proactively pursue world class performance in HSE;

- Minimise health risks to workers and local residents;
- Comply with the environmental impact mitigation recommendations that minimises environmental impacts and support sustainability principles;
- Undertake early and systematic identification of potential hazards across all disciplines and areas of exposure using standardised hazards identification and hazards analysis tools;
- Record, track, and document all actions to mitigate identified hazards across all phases of project;

- Undertake site activities based on risk mitigation measures;
- Ensure that the subcontractor selection process includes examination of subcontractor historical HSE performance and proactive HSE initiatives;
- Emphasise the consistency and adequacy of contractor, vendor, and supplier HSE management systems; and
- Conduct regular senior management reviews, both internal and external audits of the effectiveness of the HSE management system in fulfilling the policy, objectives, and targets.

The HSE targets set by the project includes:

- No Fatalities;
- No Lost Time Injuries or Illness (LTIR 0.0);
- Total Recordable Injury Rate (TRIR < 0.3);
- No Fire & Explosion;
- No Reportable Environmental and Compliance Incident;
- No Vehicle Incidents;
- No Unplanned Interruptions to the Plant.

For the purpose of establishing the category of incident, Occupational Safety and Health Administration (OSHA) definitions shall be used. These objectives and targets will be cascaded throughout the project as part of the HSE Communications Procedure and be monitored as part of the Project HSE Management Review Procedure.

### 5.3.2

#### ***Risk Management***

##### *Work Method Statement (WMS)*

Detailed Work Method Statements (WMS) shall be prepared by any person who is to carry out work on site, e.g. Contractors, Pre-commissioning engineers, etc.; for all work which has potential risks to HSE as determined by corresponding Risk Assessments (RA). This method statement will describe the work procedures, construction equipment to be used, sequence of operation and the controls necessary to achieve effective management of risks, and efficient execution of the works.

Detailed Work Method Statements shall be prepared for all critical tasks including but not limited to heavy lifts, general rigging and lifting, vessel entries, spading requirement, live line, welding, (hot taps), excavations, grating and handrail installation/ removal, and any erection work with specific risks.

Work that is deemed to be novel or unusual, any work that involves the handling of hazardous substances, unfamiliar or non-routine operation shall require to be reviewed by Safe Operations Committee (SOC).

The Work Method statement shall as a minimum describe:

- The job to be undertaken;
- The individual activities required to complete the job;
- The sequence of the various activities in the execution of the work;
- Plant, equipment, tools to be used in each activity;
- Substances/chemicals to be used in each activity (COSHH);
- Control measures and procedures to be used for each activity;
- Personal protective equipment required;
- Emergency resources/logistics required e.g. fire-watchers, fire extinguishers, fire blankets;
- Name of Task Supervisor for each activity;
- Name of Line Personnel in charge of the job;
- Novel procedures may require demonstration or training exercises; and
- Any specific or foreseeable identified hazards are to be listed.

Work method statements and the corresponding Risk Assessments shall be submitted to Sembcorp at least seven (7) working days prior to the anticipated commencement of the actual physical work at the site.

#### *Risk Assessment (RA)*

Any activities that present hazards to HSE needs to be identified. These hazards maybe identified at any stage of the project e.g. data, existing drawings, site survey investigations, design stage and constructability reviews, or may emerge during the construction or pre-commissioning/ start-up phase.

Once potential hazards are identified after the development of WMS, the risks to HSE must be assessed. The assessment should characterize the risk in terms of severity and probability based on a "5-by-5 Matrix". From the WMS, a Risk Assessment shall be developed which at best would eliminate the risk or as a minimum, would contain the risk to a reasonable and/or acceptable level.

In accordance with the pro-active approach to safety, risk management techniques shall be adopted so that potential hazards are identified and evaluated prior to execution, thereby enabling either substitution or adoption of control techniques.

Any person who is to carry out work on site, e.g. Contractors, Vendors, self-employed persons, Pre-commissioning engineers, etc., shall carry out Risk Assessments, as necessary.

Construction Manager and Field Engineers with the support of Contractor shall conduct a 'Joint Pre-commencement Review of respective Contractor WMS/RA' of all key/significant construction activities thereby identifying their loss potential (in terms of probability, frequency and severity), ensuring

clear understanding and assuring that all the required materials, tools, equipment and PPE are available and 'fit for purpose'. The findings of this assessment, together with risk assessments submitted by contractors shall form an inventory of tasks from which additional method statements and work practices shall be developed by Contractors in conjunction with Sembcorp. All such assessments shall form the basis for the Pre-Task Talk discussions.

#### *High Risk Activity Audits*

The Site HSE Manager shall produce a schedule of audits to be performed by Sembcorp and Contractor Front Line Supervision which cover those activities identified by the risk assessment procedure as presenting significant hazards. As a minimum, these shall include and may not be limited to:

- Excavations;
- Work at Heights;
- Hot Work Activities;
- Scaffolding;
- Crane Operations and Lifting Equipment;
- Confined space entry;
- Electrical lock out/tag out (LOTO); and
- NDE/Radiation

These areas shall be supplemented by audits of individual "high risk" tasks and activities as against agreed Work Method Statements and Risk Assessments. These audits shall extend beyond investigation of mere physical conditions but shall also constitute a quality type audit that concentrates upon conformance to procedures, checks and controls, and operative awareness, all of which precede field performance.

#### *HSE Procedures*

Detailed Site-specific HSE procedures, Sembcorp Corporate HSE Procedures and Good Safety Practices providing the governing HSE standards for construction and pre-commissioning activities shall be made available at the work site. These procedures shall be made available to Contractors for reference and forms the basis of the Site HSE Management System.

### **5.3.3**

#### *Safety Training*

Sembcorp recognises the critical impact of HSE training in achieving the optimum level of performance. Contractors in consultation with Sembcorp shall introduce a training programme that at all times meets the needs of the particular construction or pre-commissioning/start-up phase and its personnel. All such training shall be evaluated by the Site HSE Manager to ensure that it achieves its objectives.

Contractors shall identify and develop project-specific training modules with respect to scope of work and in compliance with applicable legal and other OSH requirements.

Construction Contractors and Pre-commissioning engineers shall be required to fully participate in the training programme. For certain key areas of work (confined space entry, work under permits) it shall be mandatory for contractor and commissioning supervision to have successfully attended any project-specific training.

Contractors shall also provide any necessary additional training so as to ensure that their personnel are at all times familiar with their tasks, legal and OSH requirements and also the preventative measures necessary to circumvent them. This is particularly necessary in relation to the handling of hazardous substances.

The foundation of any training programme shall be the project orientation and/or site HSE induction which shall be mandatory for all personnel prior to being allowed onto site unaccompanied.

#### *HSE Induction*

All site personnel shall be required to attend HSE induction before commencing work. The induction and the verification tests shall be conducted in the language conversant to the participants. Contractor may, if considered necessary, run refresher inductions for all site personnel.

Subjects covered in the inductions may include, depending on the applicable phase /scope of work at site the following:

- Induction video (where applicable);
- Overview of the programme and hazards addressed - project and plant specific;
- Issue and use of Site Identification cards;
- Driving on site;
- Personal Protective Equipment - minimum site requirements and legal considerations;
- Plant alarms, evacuation procedures and muster points;
- Smoking;
- Reporting of Accidents;
- First Aid Facilities;
- Fire Prevention and Suppression;
- Housekeeping (including cable management);
- Noise at Work;
- Legal requirements and other OSH requirements;

- Radiography;
- Permit-to-Work Systems;
- Work Method Statements/Risk Assessments;
- Pre Task /Mass Toolbox Talks;
- Scaffolding and tagging;
- Manual handling;
- Hot work including gas cylinders storage and use, spark containment;
- Respiratory Protection;
- Electrical Equipment;
- Working at heights, Safety harnesses, lifelines;
- Control of Substances Hazardous to Health, materials/contaminated land;
- Communications;
- Planning for safety - everyone's responsibilities;
- Drug and Alcohol Policy;
- Colour coding system for appliance, equipment and machines;
- Confined Spaces;
- Site Security;
- Site Prohibited items - explosives, firearms, etc.;
- Excavation; and
- Use of Hand phones on site.

The above list is not exhaustive and may be subject to revision due to the experience, trades, etc. of the audience. Site security will issue ID cards for access to the site upon successful completion of the HSE Induction.

#### *Visitors*

Visitor(s) shall liaise with their sponsor prior to entry to site. Visitor(s) shall be accompanied at all times whilst on site by their sponsor. The sponsor shall give visitor(s) who require access to construction areas an outline briefing of the site safety requirements.

#### *Training Register*

A HSE training register of all personnel that have been inducted, received additional training or re-training will be maintained by the Contractor. This register will include any statutory training and onsite training carried out by the contractors. The training register will be compared against the Site HSE Training Matrix to identify any gaps in HSE competency of all personnel

working in the project.

#### *Certification of Personnel*

Approved Persons and Qualified Persons e.g. crane drivers; fork lift drivers, mobile platform operators, confined space assessors, radiographers; scaffold erectors and first aid personnel shall be registered/certified by Statutory and its accredited testing/certification agencies demonstrating their competency to perform their works.

All operators of mobile equipment shall have at least 2 years of experience in operating the relevant equipment. Crane operators shall have at least 5 years' experience in crane operations. Newly appointed operators of mobile equipment without the necessary industrial experience shall be prominently identified.

#### *Letter of Appointment*

Specific functions such as Safety Supervisor, Lifting Supervisor, Signalmen, Rigger, Scaffold Supervisor, Formwork Supervisor, Forklift Operator etc., shall be issued with "Letter of Appointment" which, details the roles and responsibilities of each function.

### **5.3.4**

#### ***HSE Meetings***

Effective communications raise HSE awareness and are vital to the successful implementation of the HSE Plan. Communications take many forms but their common objective is to improve understanding of HSE matters and from this, to obtain the support, co-operation and commitment of all interested parties. An overall HSE Communication meeting matrix shall be developed.

#### *Contractor Kick-off Meeting*

Prior to site mobilisation a dedicated kick off meeting will be held and attended by the representatives of Sembcorp and the Contractor. Agenda may include, as applicable:

- Scope of work;
- Type and nature of work;
- Contractor's HSE Plan;
- Allowable working hours;
- Confirm that work can be safely executed within the proposed programme of works;
- HSE induction/training requirements;
- Personnel Protective Equipment/Clothing;
- Plant and equipment, standards and inspection requirements;
- Noise restriction including local requirements;
- Interfaces with other contractors;

- Auditing - participation and involvement;
- Legal requirement and other OSH requirements;
- Hazardous materials to be used;
- Reporting of incidents and accidents;
- Permit System - administration and requirements;
- Working on live operating plant;
- Work Method Statements/Risk Assessments;
- Any other specific anticipated hazards related to the work scope;
- Use of Hand phones on site;
- Environmental considerations.;
- Communication/Language; and
- Work Stoppages

#### *Daily/Weekly Progress Meeting*

A daily/weekly progress meeting will be held with each contractor. The HSE representatives of Sembcorp and Contractor will attend this meeting. HSE will be the first topic on the meeting agenda. HSE issues, progress and performance will be reported. Where necessary action plans will be produced and implemented.

#### *HSE Committee Monthly Safety Review Meeting*

A monthly safety review meeting will be held. The frequency and timing of this meeting may be adjusted accordingly.

Attendees will include:

- Project Manager
- Construction Manager (Sembcorp) – Chairman
- Site HSE Manager/Officer (Sembcorp) – Secretary
- Field Engineers (Sembcorp) - Rotating Basis
- Site Managers (Contractors)
- Safety Representatives (Contractors)
- Pre-Commissioning Manager

The agenda for the meeting will be structured around the following:

- Matters arising from last meeting;
- Accidents, incidents and near misses;
- Feedback on Site incidents;

- Publicity/promotion/initiatives;
- Monthly look ahead of activities;
- Anticipated concerns;
- Interface between Contractors; and
- Feedback from site personnel.

Chairman shall preside over the HSE Committee to achieve the purpose planned and has authority over members for the improvement of HSE Management System.

The Secretary will prepare the minutes of meeting. Presentation will be made to the Committee on the status of inspection reports, incident investigations and other related reports.

Members will assist the Chairman in the implementation of the Construction HSE Plan and provide constant surveillance in the field on all matters pertaining to health, safety, security, and environmental concerns on the construction work site.

#### *Safe Operations Committee (SOC) Meeting*

Safe Operations Committee (SOC) meetings may be called to address special circumstances such as:

- Work involving novel construction techniques;
- Work requiring special instructions and precautions; and
- Reporting the impact on HSE of any design work concurrent with the construction phase i.e. identifying potential hazards which were unknown at the contract award stage.

#### *Toolbox/Pre-Task Talk (PTT)*

Toolbox/Pre- Task Talks shall be conducted prior to commencement of any new task/location or when task/location conditions changes, and as minimum shall be done every morning and after lunch typically for 5 to 10 minutes. Contractor's Task Supervisor shall conduct safety instruction briefing and must be conducted in a language understood by the workforce. PTT shall be conducted at the immediate task locations or as close as possible. The basis for providing the safety instructions shall be the result of the last minute risk assessments.

A Toolbox/Pre-Task Talk form is developed and shall be accomplished by the Task Supervisors for every PTT and attendance signed by the members of the team.

#### *Mass Safety Briefing*

Mass "Safety Briefings" are mandatory and shall be held once each month, as a minimum. These will be conducted by the Contractors' Line Management, in the language understood by the workforce, and should address the

application of safety rules and procedures to the hazards of current work, and dissemination of key Project HSE information.

A roster of all attendees will be maintained by the Contractor, together with a record of the topics discussed which shall be circulated to the Site HSE Team.

### 5.3.5 *Safety Rules and Regulations*

#### *Fire Prevention and Protection*

Contractors are primarily responsible for fire prevention within all project construction work areas. All operations shall be conducted in a manner to minimise the risk of a fire.

This will be achieved by:

- Good housekeeping. All areas must be kept free from debris and waste material;
- Storing flammable materials in a systematic controlled way;
- Training on basic fire prevention and suppression;
- Containment methods to be employed at any potential sources of ignition e.g. fireproof blankets around welding operations or flame cutting operations. Fire-watchman equipped with fire extinguishers will be located at all hot work operations;
- Integrity of electrical equipment;
- Locating adequate fire protection equipment at areas of hot work;
- Isolating flammables from sources of ignition;
- Mobilising fire-fighting facility in the event of fire;
- Providing fire extinguishers adjacent to all mobile diesel driven weld sets, compressors, pumps etc.; and
- Utilising fire prevention surveillance systems, alarm, detectors, etc.

#### *Authority to Stop Work*

All training, group meetings, publicity, etc. shall be conducted in native language with translation to the necessary languages in order to ensure full comprehension amongst the workforce. This shall incorporate English as a minimum, as well as reflecting the multi-national compilation of the workforce. It is the primary responsibility of respective Contractors to ensure that the requirement for multi-lingual communications are addressed and effectively disseminated to all their personnel. Requirements for multilingual communication shall be available for critical operational control system such as Permit to Work.

## 5.4

### *MEASURES TO PREVENT ACCIDENTS OR LIMIT THE CONSEQUENCES OF A MAJOR ACCIDENT*

The project is at the preliminary stage in which measures to prevent accidents or limit the consequence of major accidents still rely on the procedural measure to safeguard the plant from potential hazards. Physical measures and safety procedure for FG incidents prevention shall be provided in detail design stage. In this section, recommendations with respect to design construction, installation, commissioning, operation and emergency handling of fuel gas facilities at the CCGT power plant are discussed.

When the information is available during EPC stage, the following information will be combined and applied for the Emergency Response

Plans:

- Zoning Classification
- Protection against static discharge
- Corrosion protection for pipelines
- Compliance with specific design codes
- Newly constructed equipment or plant procedures
- Maintenance attitude / procedures
- Inspection of Fire Service Installations and Equipment
- Purging of Fuel Gas Equipment
- Surveillance and Inspection of Fuel Gas Systems
- Plant Modifications
- Other Emergency Equipment

### 5.4.6

#### *Temp works*

##### *Warning Signs during construction works*

When systems are pre-commissioned and commissioned, these systems could be within an area where construction activities are still being carried out.

The resultant 'live' lines will present a potential hazard as:

- a) Steam and condensate lines will be hot and under pressure.
- b) Other utility lines will be under pressure.

All 'live' lines must be clearly identified and isolated and warning signs attached and additionally identified with tape. Signs must denote state of line i.e. 'HOT' and 'UNDER PRESSURE' etc.

#### **5.4.7 *Staff Training (various) / Demonstration of correctly designed, installed and maintained critical equipment / Drills and exercises***

##### *HSSE Training*

The project management team shall ensure that all personnel are given the required health, safety, security and environment (HSSE) training to equip them with the HSSE knowledge, skill and attitudes that will enable them to perform their duties with due regards to HSSE, in accordance with the procedure for HSSE Training (SDCI-HSP-1002-05).

The project management team shall ensure that the mandatory HSSE training is provided for personnel in compliance with the relevant statutory and other local legal requirements, applicable standards and code of practices.

The project management team shall update the HSSE training received by all personnel in the HSSE Training Matrix.

The project management team shall ensure that the In-House HSSE Rules and Regulations are implemented on the project site, in accordance with the procedure for In-House HSSE Rules & Regulations (SDCI-HSP-1002-07).

No person shall work on the site prior to successfully completing the site HSSE induction.

##### *Drills*

The project management team shall ensure that the Project Emergency Response Drill is conducted at least once prior to work commencement and subsequently at every 6-monthly intervals.

#### **5.4.8 *First-Aid Rescue***

First-Aid and rescue procedures have been documented in the Project Emergency Preparedness and Response Plan. Details are provided in *Section 6.2*.

## 6 COMMUNICATIONS AND EMERGENCY SYSTEM

### 6.1 COMMUNICATION

#### 6.1.1 Alarms

Fire and Gas alarms are activated manually after event is discovered by project personnel. Vocal alarms as per emergency response are given immediately after discovery of event to alert workers. Details of emergency response are provided in *Section 6.2*.

#### 6.1.2 *Accident and Major Incident Reporting and Investigation Procedure*

The Project Accident and Major Incident Reporting and Investigation Procedures are detailed in the Project Emergency Response Flowchart, which are provided in the Project HSE Manual [2].

As detailed in the Project HSE Plan, the procedures of incident investigation and analysis are provided in the following sections.

#### 6.1.3 *Injury and Near-Misses*

All incidents resulting in injury or near-misses to employees of Sembcorp, Contractors, Sub-contractors, 3<sup>rd</sup> parties working on the project, or to any visitor must be reported immediately to the Sembcorp.

The relevant Construction Lead, Field Engineer and with the support of the Site HSE Manager/Officer shall investigate all injuries and near-misses immediately and the details recorded on the Accident/Incident Report Form. When causative factors have been established, remedial action shall be implemented without delay.

Where an injury requires offsite treatment, the Sembcorp Construction Manager shall initiate an impartial investigation and a detailed report as may be necessary shall be generated.

An incident management and protocol flowchart shall be developed and will form part of the Site Incident Management, Communication and Investigation process.

The analysis of Accident Reports and formal investigation will assist in the identification of trend processes and activities occasioning physical injury and will enable the preventive procedures to be revised if deemed necessary.

#### 6.1.4 *Statistics and Reporting Requirements*

Contractor is responsible for informing the Local Authorities and Sembcorp of any reportable accidents or incidents in a timely manner.

An initial incident notification system for the reporting of accidents and incidents including near misses shall be operated.

Contractor shall keep records of all injuries at work site and will promptly report any reportable injury to Sembcorp and deal with the appropriate authority regarding any reportable injuries.

Contractor shall ensure that all accidents and incidents are investigated in accordance with Sembcorp requirements.

A monthly report shall be developed for Monthly HSE Reporting and copy provided to Sembcorp Group HSE. The project safety statistics shall include, but not limited to:

- Total Hours Worked;
- Statutory Reportable Cases;
- Fatalities;
- Lost Time Incidents;
- Restricted Work Cases;
- Medical Treatment Cases;
- First-aid Cases;
- Property Damages;
- Dangerous Occurrences;
- Environmental Incidences;
- Near-misses;
- Behavioural Based Safety Observations;
- Lost Time Injury Rate (based on 200,000 work hours); and
- Total Recordable Incident Rate (based on 200,000 work hours).

#### *Monthly Health, Safety and Environmental Report*

Sembcorp HSE Manager/Officer shall prepare a monthly HSE report; this report shall cover HSE activities up to the last day of the month. The full report shall be prepared and submitted to Owner and Group HSE by the 5<sup>th</sup> of each month to cover the previous month's activities.

The HSE report, which forms part of the monthly progress report shall include, for the reporting period:

- A tabulation of all accidents and near misses that occurred and their apparent cause;
- A tabulation of all hazards observed at the work site, a description of corrective action taken to deal with them, the individual to rectify the

shortfall;

- A summary of the contractors HSE activities, problem areas and corrective actions, government visits and HSE audits;
- A tabulation of hours worked for staff, supervision and labour, including lost time statistics; and
- Safety Training Course Schedule for the coming month.

Additionally, from the beginning of the construction phase, graphs and statistics shall be prepared, on a cumulative basis showing recordable injury rates and lost workday injury rates.

### **6.1.5**      *Emergency Contacts*

Contact details for company and external organisations that may need to be contacted in the event of an emergency shall be provided in the pro-forma as shown in Project Emergency Preparedness & Response Plan [1].

## **6.2**      *EMERGENCY PLAN*

### **6.2.1**      *On-site Emergency Response Procedures*

The emergency response procedures for a number of scenarios have been provided in the Project Emergency Preparedness and Response Plan. Scenarios include fire outbreak, failure / collapse of structure, chemical spillage, water / gas pipe leak / burst, electrical power supply damage and worker injuries. A detail description as extracted from the aforementioned document is provided in the following sections. The organisation structure and responsibilities of the Emergency Response Team (ERT) members have been provided in *Section 5.2*. The Emergency Evacuation layout Plan and Emergency Response Flowchart have been provided in the Project Emergency Preparedness & Response Plan [1].

### **6.2.2**      *Fire Outbreak*

1. The person(s) who spotted the fire shall raise the alarm by shouting "Fire! Fire! Fire!" or activating fire alarm / siren, etc. so as to alert nearby persons and get help.
2. The person(s) who spotted the fire shall inform the key project personnel and any of the project Emergency Response Team (ERT) members immediately.
3. If it is a small fire, the person(s) who spotted the fire may attempt to use a portable fire extinguisher to control the fire from spreading.
4. The person(s) shall check for any casualty. If there is casualty, the person(s) may attempt to rescue the casualty if it does not pose any danger to him / them.
5. Upon reaching the emergency location, the project ERT shall take over the control of the area and all other persons shall leave the area

immediately.

6. The First-Aid Team shall administer first-aid treatment to the injured if there are any injured personnel.
7. The project ERT shall call the Incident / Deputy Incident Commander and report the status of the emergency.
8. Based on the information given, the Incident / deputy incident commander shall assess the seriousness of the emergency incident and decide on the next course of action.
9. If the fire is beyond control or lives are endangered, emergency evacuation shall be activated. All personnel shall assemble at the emergency assembly area immediately.
10. In the event of the activation of emergency evacuation, the respective person(s) in-charge shall commence headcount of their personnel and ensure all their personnel are accounted for. The person(s) in-charge shall report their headcount and any missing personnel and their last known location to the site HSSE personnel / deputy incident commander immediately.
11. The Rescue team shall be informed and instructed to organise search and rescue of all reported missing personnel immediately.
12. The incident / deputy incident commander shall liaise with all relevant external parties (i.e. authorities, emergency services, etc.) involved.
13. The incident / deputy incident commander shall inform the Project Director and HOD (HSSE) of the emergency incident / situation and keep him/her informed of the status of the emergency.
14. After the incident, the incident / deputy incident commander shall compile an emergency incident report and submit the report to the Project Director and HOD (HSSE).
15. The incident / deputy incident commander shall ensure that all other official documentation required to be submitted to the relevant authorities are compiled and submitted as required.

#### *Recommendations*

- Recommendation 9: Ensure sufficient coverage of Fire & Gas Detectors. Ensure sufficient coverage of fire fighting system such as hydrants, monitors, etc.

### **6.2.3**

#### ***Failure / Collapse of Structure***

1. Any person(s) who discovers the occurrence of the emergency situation shall raise the alarm by shouting "Help! Help! Help!".
2. The person(s) who discovered the emergency situation shall inform the project key personnel and any of the project ERT members immediately.

3. If the situation does not pose any danger, the person(s) shall remain at the emergency location and provide assistance such as helping the injured, warning unknowing personnel to stay away from the affected areas, etc. until the project ERT arrives.
4. Upon reaching the location of the emergency incident / situation, the project ERT shall take over the control of the area and all other persons shall leave the area immediately. The project ERT shall cordon off the affected area and instruct all personnel to keep away from the danger locations, except for project ERT members who are conducting rescue and/or evacuation of the personnel.
5. The project ERT shall call the Incident / Deputy Incident Commander and report the status of the emergency.
6. Based on the information given, the Incident / deputy incident commander shall assess the seriousness of the emergency incident and decide on the next course of action.
7. If the situation is beyond control and/or endangers the lives of personnel, emergency evacuation shall be activated.
8. If there is an outbreak of fire, the fire-fighting team shall commence to put out the fire.
9. The rescue team shall check for any casualty or persons trapped in the location and conduct rescue.
10. The first-aid team shall administer first-aid treatment to the injured if there is any.
11. The incident / deputy incident commander shall liaise with all relevant external parties (i.e. authorities, emergency services, etc.) involved.
12. In the event of the activation of emergency evacuation, the respective person(s) in-charge shall commence headcount of their personnel and ensure all their personnel are accounted for. The person(s) in-charge shall report their headcount and any missing personnel and their last known location to the site HSSE personnel / deputy incident commander immediately.
13. The incident / deputy incident commander shall inform the Project Director and HOD (HSSE) of the emergency incident / situation and keep him/her informed of the status of the emergency.
14. After the incident, the incident / deputy incident commander shall compile an emergency incident report and submit the report to the Project Director and HOD (HSSE).
15. The incident / deputy incident commander shall ensure that all other official documentation required to be submitted to the relevant authorities are compiled and submitted as required

*Chemical Spillage*

1. The action to be taken in the event of oil or chemical spill depends on:
  - a. The quantity spilled
  - b. The environment affected (e.g. confined within project site, spillage to surrounding land, into the sea, etc.)
  - c. The type of oil or chemical (e.g. hazardous or non-hazardous, poisonous, explosive, etc.)
2. In all cases, the project ERT shall be informed of any type of spillage of oil or chemical and they shall recommend the actions to be taken as according to the type and severity of the spillage.
3. If the oil / chemical spillage is non-hazardous and is confined within the boundary of the project site, the project ERT shall:
  - a. Try to contain the oil / chemical spillage and prevent from spreading
  - b. Isolate the source of the spill
  - c. Ensure that the spillage do not flow into the public drainage system
  - d. Clean up the spill with the appropriate clean-up measures stated in the oil / chemical's Safety Data Sheet (SDS)
  - e. If the project does not have the capability to conduct cleaning up of the spillage, the project ERT shall contact external qualified cleaning contractors to carry out the clean-up operation.
4. In the event of non-hazardous oil or chemical spillage to public areas (e.g. public roads, drainage, etc.) the project ERT shall:
  - a. Stop any further spillage from the project site by blocking all leakage points.
  - b. Carry out spillage control using the most suitable method of containment, depending on the type of oil / chemical spillage and the estimate volume of spillage
  - c. Prevent further flow of spillage into the public areas by blocking the entry points (at locations such as drains, creeks, water courses, sewers, etc.) by measures such as using sand bags, provide bunding around entry points, etc.
  - d. Use the available types of spillage control / clean-up kit, sand, soil or other materials, etc. to further contain and clean up spillage.
  - e. Ensure that all personnel involved in the spillage control work are issued with and attired in the appropriate personal

protective equipment to prevent control of the spillage materials with the personnel.

- f. Ensure that contaminated material / waste are stored in sealed containers and properly labelled. All contaminated material / waste shall be disposed of properly in accordance to Myanmar Environment's regulations.
  - g. Arrange for immediate remediation of the affected areas, after the spillage is brought under control.
  - h. Contact the public emergency services such as police to control the situation if the measures to stop the spillage from the project site are not effective.
5. The PM or his designate shall liaise with all relevant external parties (i.e. authorities, emergency services, etc.) involved.
  6. The PM or his designate shall inform the Project Director and HOD (HSSE) of the incident / situation and keep him/her informed of the status of the emergency.
  7. The PM or his designate shall compile an incident report and submit the report to the HOD (HSSE).
  8. The PM or his designate shall ensure that all other official documentation required to be submitted to the relevant authorities are compiled and submitted as required.
  9. If there is spillage into the public drainage, the incident / deputy incident commander and Project Director shall inform the relevant authority (i.e. PUB) and work closely with the authority to control and mitigate the spillage.

#### **6.2.5 Water/Gas Pipe Leak**

1. The person(s) discovering the water / gas leak shall raise the alarm by informing the parties responsible / involved in the source of the gas leak.
2. If the water / gas leak is controllable, the responsible party shall shut off the source of water / gas leak immediately (e.g. turn off the valves / mains of the water / gas supply, etc.).
3. If the water / gas leak is uncontrollable, such as due to the damaged / failure of its containment, damage or rupture of piping / valves, etc. the party responsible shall inform the key project personnel, any members of the project ERT.
4. The ERT shall response within ½ hour (2 hours after office hour) and assess the situation while work together with the Facilities Management representative for external help. And at the meantime, the plumber on standby at the site shall be activated.
5. If it is safe to do so, the responsible party shall assist in cordoning off the

affected area to prevent further unauthorised entry until the project ERT arrives and take over control of the emergency area.

6. For Gas Leak, the project ERT shall:
  - a. Raise the emergency evacuation alarm / siren to alert all personnel to start evacuation to the emergency assembly area & ensure the smooth evacuate of all personnel in the immediate vicinity.
  - b. Ensure all users of the gas source is informed of the emergency situation and to shut off all gas supply
  - c. The responsible party shall inform the provider of the gas supply immediately
  - d. Ensure all sources of ignition are removed or extinguished & try to isolate the source of the gas leak
  - e. Ensure that the area is ventilated as much as possible
7. If there is an outbreak of fire, the fire-fighting team shall commence to put out the fire.
8. The rescue team shall check for any casualty in the location and conduct rescue.
9. The first-aid team shall administer first-aid treatment if there is any injured.
10. The project ERT shall contact the Incident / Deputy Incident Commander and report the status of the emergency.
11. Based on the information given, the incident / deputy incident commander shall assess the seriousness of the emergency incident and decide on the next course of action.
12. In the event of the activation of emergency evacuation, the respective person(s) in-charge shall commence headcount of their personnel and ensure all their personnel are accounted for. The person(s) in-charge shall report their headcount and any missing personnel and their last known location to the site HSSE personnel / deputy incident commander immediately.
13. The incident / deputy incident commander shall liaise with all relevant external parties (i.e. authorities, emergency services, etc.) involved.
14. The PM or his designate shall inform the Project Director and HOD (HSSE) of the incident / situation and keep him/her informed of the status of the emergency, compile an emergency incident report and submit the report to the Project Director and HOD (HSSE).
15. The PM or his designate shall ensure that all other official documentation required to be submitted to the relevant authorities are compiled and submitted as required.

### *Recommendations*

- Recommendation 9: Ensure sufficient coverage of Fire & Gas Detectors. Ensure sufficient coverage of fire fighting system such as hydrants, monitors, etc.

#### **6.2.6** *Electrical Power Supply Cable Damage*

1. The person(s) discovering the electrical power supply cable damage due to excavation work shall raise the alarm by informing the parties responsible and the site management personnel.
2. If the electrical cable damage is externally scratched, the responsible party shall inform the site management personnel immediately. The electrical contractor shall be activated to provide necessary protective cover.
3. If the electrical cable is damaged seriously and there is power failure, the party responsible shall inform the key project personnel, any members of the project ERT.
4. The ERT shall response within ½ hour (2 hours after office hour) and assess the situation while work together with the Client Management representative for external help. And at the meantime, the electrical jointer on standby shall be activate and await for further instructions.

#### **6.2.7** *Worker Injuries*

1. Any person(s) who discovers the occurrence of the injured shall raise the alarm by shouting “Help! Help! Help!”.
2. The person(s) shall inform the project key personnel and any of the project ERT members immediately.
3. If the situation does not pose any danger, the person(s) shall remain at the emergency location and provide assistance such as helping the injured, warning unknowing personnel to stay away from the affected areas, etc. until the project ERT arrives.
4. Upon reaching the incident location, the project ERT shall take over the control of the area. The project ERT shall cordon off the affected area and instruct all personnel to keep away from the danger locations, except for project ERT members who are conducting rescue and/or evacuation of the personnel.
5. The project ERT shall call the HSSE Officer /Coordinator and report the status of the injured worker.
6. For first aid treatment case, the first-aid team shall administer first-aid treatment to the injured or the injured walk to the first aid treatment room for basic treatment.
7. For minor injury case such as the injured is still conscious and is able to move with assistance, a transport is arranged to send the injured to

nearest clinic/ hospital and staff/ or subcontractor supervisor will accompany the injured.

8. For severe injury case such as injuries sustained are critical and Injured is either unconscious or is not able to move. The Project Manager/ or HSSE Officer /Coordinator shall give instructions to activate Project Security to lead Responders to the location.
9. Project Manager shall informs Management/ Client (PCo) Management and provide situation verbally report on regular interval if the severe injury is occurred.
10. Follow-up with Incident Reporting and Investigation when the injury is reportable case. The incident report shall send to the relevant parties.

#### **6.2.8 *Action by External Emergency Services***

A list of external emergency contact has been developed and it will be updated as the project progress.

##### *Recommendations*

- Recommendation 10: Primary emergency communication system should be available with emergency response teams and local authority personnel involved with emergency response. Secondary / alternative emergency communication system should also be available for emergency response.

#### **6.2.9 *Emergency Evacuation Procedures***

Emergency Evacuation Procedures as detailed in the Project Emergency Preparedness and Response Plan are as follows:

1. Everyone shall stop work immediately
2. Disconnect all power supply to machinery and equipment
3. Lower all suspended loads from the lifting machines onto a firm ground
4. All personnel shall take the nearest emergency exit / evacuation route and assemble at the designated emergency assembly area
5. Project ERT members shall also assemble at the emergency assembly area with their emergency response equipment.
6. All personnel shall assemble or queue up orderly at their respective designated location within the emergency assembly area.
7. The respective person(s) in-charge shall ensure all their personnel are assembled at the correct designated location.
8. The respective person(s) in-charge shall conduct head count of their personnel and record the headcount in the Project Emergency Evacuation Register.
9. The person(s) in-charge shall submit the emergency evacuation register to the Incident Commander / Deputy Incident Commander and report if

there is any missing personnel.

10. The Incident Commander or his deputy shall determine whether there is a need for further assistance from external emergency services agencies.
11. Re-entry into the immediate vicinity of the emergency incident / situation area shall be restricted to only authorised personnel (i.e. project ERT members and authorities, emergency services, etc.).
12. Clearance to re-enter the emergency incident site for the rest of the project personnel is subjected to the approval of the Incident Commander.

The emergency escape route and emergency assembly area are provided in Figure 6.1.

**Figure 6.1** Project Emergency Evacuation Layout Plan

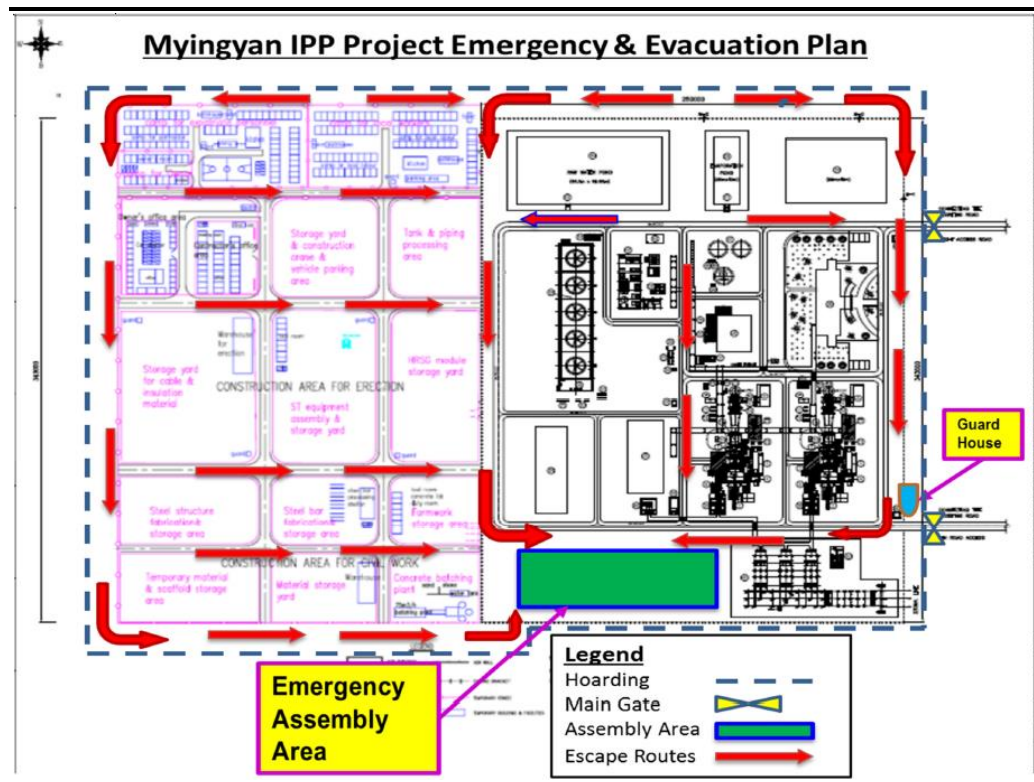

*Recommendation*

Recommendation 6: Layout study should be conducted to assess adequacy of separation distances from major hazard installations to sensitive equipments, buildings and emergency assembly area locations.

**6.2.10** *Ensure adequacy and effectiveness of Emergency Plan*

*HSE Audit*

As per the Project HSE Plan, HSE audits will be performed and reported in the monthly HSE report.

The audit will cover the following aspects and others as deemed necessary by the Site HSE Manager:

- Excavations
- Work at Heights
- Hot Work Activities
- Scaffolding
- Crane Operations and lifting Equipment
- Confined Space Entry
- Electrical lock out / tag out
- NDE / Radiation

The HSE Audit is referred to in the Project HSE Plan, presented in *Section 5.3*.

## 7 CONCLUSIONS AND RECOMMENDATIONS

### 7.1 CONCLUSIONS

A major accident prevention policy has been provided and a safety management system has been put in place to implement the policy. As the CCGT Power Plant project is in the preliminary design stage, preliminary hazard identification has been performed on the power plant. Studies such as HAZID, HAZOP and QRA studies will be performed as the project proceeds into the EPC stage. Some measures have been put in place to minimize the risk of hazardous events; general recommendations have been made to further supplement the measures currently considered. Safety and reliability have been considered in the design, construction, operation and maintenance of the CCGT power plant. Emergency plans have been developed as detailed in project documents and some recommendations have been made to the plans.

### 7.2 RECOMMENDATIONS

Recommendation 1: all pipes and equipment should be suitably coated against external corrosion. Also, lagging should be provided with removable panel to facilitate routine inspection of the condition of the pipework surface. (Refer to *section 4.1.1*)

Recommendation 2: Area around the gas supply pipeline and valve stations should be zone-classified and access-controlled to eliminate any source of ignition. (Refer to *section 4.1.1*)

Recommendation 3: Consider implementing a HEMP (Hazard and Effects Management Process) to identify and manage the major accidental hazards. (Refer to *section 4.1.1*)

Recommendation 4: a Quantitative Risk Assessment (QRA) needs to be performed during EPC stage for the Power Plant in order to evaluate the risk due to the explosion events to the On-site, Off-site population as well as the adjacent facilities. The Emergency Response Plan needs to be updated in order to take into account these explosion events. (Refer to *section 4.1.2*)

Recommendation 5: a HAZID for commissioning/ start-up can be performed during EPC stage in order to identify all potential risk due to these operations. (Refer to *section 4.1.2*)

Recommendation 6: Layout study should be conducted to assess adequacy of separation distances from major hazard installations to sensitive equipments, buildings and emergency assembly area locations. (Refer to *section 4.1.3*)

Recommendation 7: Comprehensive soil investigation survey is recommended to investigate ground settlement / subsidence risk. (Refer to *section 4.2.4*)

Recommendation 8: The design of the Power Plant should be such that the impacts due to severe earthquakes are minimized. (Refer to *section 4.2.5*)

Recommendation 9: Ensure sufficient coverage of Fire & Gas Detectors. Ensure sufficient coverage of fire fighting system such as hydrants, monitors, etc. (Refer to *section 6.2.2 and 6.2.5*)

Recommendation 10: Primary emergency communication system should be available with emergency response teams and local authority personnel involved with emergency response. Secondary / alternative emergency communication system should also be available for emergency response. (Refer to *section 6.2.8*)

Recommendation 11: Safety and reliability of the CCGT power plant should be review regularly during the design, construction, and operational phases.

## REFERENCES

- [1] Project Emergency Preparedness & Response Plan for Proposed Development of the Myingyan Gas-fired Combined Cycle Power Project, Revision 0
- [2] Project HSE Manual, Hazard / Aspect Identification, Risk / Impact Assessment and Risk Controls, P2-01, Revision 6
- [3] Health, Safety, Security and Environment Plan (HSSE Plan) for Proposed Development of Myingyan Gas-fired Combined Cycle Power Project - Myanmar
- [4] Project HSE Plan Rev.01, May 2015
- [5] QRA Study for Fuel Gas Pipeline from MOGE Gas Station to a green-field Combined Cycle Gas Turbine Power Plant in Myingyan, Myanmar: QRA Report, August 2015
- [6] Maung Thein et al, J. Earthquake and Tsunami 03, 43, 2009
- [7] ERM-Hong Kong Ltd for the Water Supplies Department, Reassessment of the Chlorine Hazard for Eight Existing Water Treatment Works (C1963), 2002
- [8] Myanmar Information Management Unit, Flood Inundated Area in Myinmu, Myaung, Myingyan, Ngazun and Yesagyotownships, Sagaing, Mandalay and Magway Region, August 2015
- [9] Environmental Resources Management, Myingyan CCGT ESIA Chapter 2, Process Description and Alternatives, July 2015

Appendix A

## QRA Input Data

*INTRODUCTION*

This is a table of input data used in the QRA study for the gas facilities at Myingyan CCGT Power Plant Project.

The purpose of the listing is to confirm that all results derived from the QRA study remains valid.

Each item that may have an impact on the risk of a major accident is listed here. In order to remain within the scope of this study, only items directly related to Natural Gas or that may cause or result from escalation of a Natural Gas incident, are considered.

For each item, the table shows:

- The item considered during the QRA;
- The assessed value or significance of the item;
- How the assessment was derived, including source of information where appropriate; and
- Reference to the relevant QRA study report.

## A2 QRA INPUT DATA

### Gas Supply Pipeline QRA Input Data

Item number	Item	Assessment	How derived	Reference
1	Atmospheric conditions	The atmospheric pressure, ambient temperature and relative humidity are 1.013 bar, 28°C, and 70% respectively.	Information from Sembcorp	Gas Supply Pipeline QRA Report
2	Local meteorology.	Wind speed and stability data tabulated.	Information from Lakes Environment	Gas Supply Pipeline QRA Report
3	Offsite population.	Base Case (Local Area): 100 persons /km <sup>2</sup> . Comparison Case (Urban Area): 723 persons / km <sup>2</sup>	Myanmar Census and World Bank Indicators	Gas Supply Pipeline QRA Report
4	Literature: Relevant previous incidents.	Incidents reviewed up to 2013.	US Gas Pipeline Incident Database, 1984 to 2013 European Gas Pipeline Incident database, EGIG 1970 to 2013	Gas Supply Pipeline QRA Report
5	Hazards associated with onshore pipeline.	Nearby work; corrosion; defect in material or construction; improper operation; defect due to pressure cycling; external event e.g. flooding, subsidence.	European Gas Pipeline Incident database, EGIG 1970 to 2013	Gas Supply Pipeline QRA Report
6	Causes of spontaneous failure of gas equipment.	Material defect, construction defect, corrosion, erosion, vibration, stress, fatigue, impact, overload (e.g. overpressure).	ERM In-house Incident Database collected from wide range of international database such as European Gas Pipeline Incident database and US Gas Pipeline Incident Database.	Gas Supply Pipeline QRA Report

Appendix B

## QRA Recommendations

***INTRODUCTION TO RECOMMENDATION LISTS***

This is a table of recommendations arising in the previous QRA study.

Only recommendations having a significant risk reduction effect on major accident hazards are considered in detail here. Recommendations that are simple clarifications, drawing corrections and other minor issues are omitted for brevity.

The purpose of this list is to show that every significant residual risk arising in previous safety studies of the Myingyan CCGT Power Plant gas facilities has been addressed and adequately controlled. These recommendations are shown in *Section B2*.

For each item, the table shows the text of the recommendation, with additional clarification or explanation where needed.

## B2 RECOMMENDATION LISTS

### *Gas Supply Pipeline QRA Report*

<b>Recommendation Number</b>	<b>Recommendation</b>
1	Consider hot tapping as a high risk activity that is a likely cause of gas leakage. Ensure that all hot tapping activities are carried out only by trained and authorized personnel.
2	Consider implementing crash barriers and control of vehicle access, onsite speed limits and driver training programme to reduce risk of gas leakage incident arising from vehicle striking piping or equipment.
3	Consider implementing routine corrosion monitoring to reduce risk of gas leakage due to internal corrosion of pipeline.
4	Consider implementing routine inspection of coating integrity to reduce risk of gas leakage due to damaged coating.